



WESTCAR s.r.l.

ROTOFLEXI

ITA
ENG

GIUNTI ELASTICI FLEXIBLE COUPLINGS

- RAPIDA SOSTITUZIONE DELL'ELEMENTO IN GOMMA SENZA SPOSTAMENTO ASSIALE DEI MOZZI
- ASSORBIMENTO DELLE VIBRAZIONI TORSIONALI
- PER COPPIE FINO A 4000 Nm.
- QUICK REPLACEMENT OF THE RUBBER ELEMENT WITHOUT AXIAL HUBS MOVEMENT
- TORSIONAL VIBRATIONS ABSORPTION
- FOR TORQUES UP TO 4000Nm





PRODOTTI WESTCAR WESTCAR PRODUCTS

Giunti idraulici ROTOFLUID per potenze fino a 4000 kW

ROTOFLUID hydraulic couplings for rated power up to 4000 kW



Giunti a denti ROTOGEAR per coppie fino a Nm. 383.000

ROTOGEAR tooth gear couplings for torques up to 383.000 Nm

Giunti idraulici ROTOFLUID GGG (con casse in ghisa) per potenze da 100 a 6000 kW

ROTOFLUID GGG hydraulic couplings (with cast-iron casing) for rated power from 100 to 6000 kW



Giunti elastici ROTOFLEXI® ad anello in gomma a rapida sostituzione senza spostamento dei mozzi per coppie fino a 4.000 Nm.

ROTOFLEXI® flexible couplings with quick replacement of the rubber element without axial hubs movement. For torques up to 4.000

Giunti idraulici ROTOFLUID-SCF/DCF con camera di ritardo semplice/doppia

ROTOFLUID-SCF/DCF hydraulic couplings with simple/double delay chamber

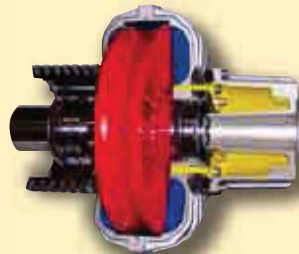

Giunti a lamelle HBX - GCX - HPX. Giunti con spaziatore HBSX - GCSX - HPSX - BE. Coppie fino a 1.043.300 Nm

HBX - GCX - HPX disc couplings. With spacer HBSX - GCSX - HPSX - BE. Torques up to 1.043.300 Nm

Giunti idraulici ROTOFLUID con tripla camera di ritardo e coppia di avviamento uguale alla coppia nominale del motore

ROTOFLUID hydraulic couplings with triple delay chamber and starting torque same as nominal motor torque



Giunti elastici ROTOPIN a pioli con sfilamento assiale per coppie fino a 300.000 Nm

ROTOPIN flexible couplings with pins and buffers axially sliding. For torques up to 300.000 Nm

Freni a ceppi e freni a disco con servofreno

Drum and disc brakes with brake servo



Giunti elastici ROTOGRID con lamelle rastremate per coppie fino a Nm. 169.500

ROTOGRID flexible taper grid couplings. For torques up to 169.500 Nm

SOFTSTART
Avviatore statico a controllo digitale per potenze fino a 750 kW.
Funzione risparmio energetico
Controllo colpo di ariete
Programmabile anche via RS 485

SOFTSTART
Static starter with digital control for rated power up to 750 kW.
Energy saving function.
Water hammering control.
Programming also via RS 485

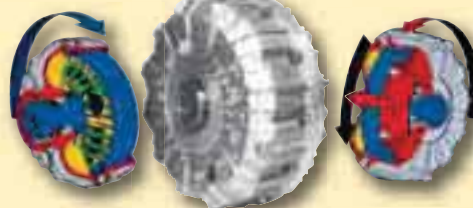

Giunti idromeccanici ROTOMECH ad accelerazione idraulica con innesto meccanico-centrifugo senza scorrimento a regime

ROTOMECH hydromechanical couplings with hydraulic start-up and centrifugal mechanical lock-up with zero slip at running. For rated power up to 1500 kW



A RICHIESTA SI POSSONO
FORNIRE I PRODOTTI
CERTIFICATI ATEX.

INDICE GENERALE

CONTENTS

Generalità.....	Pag. 2
<i>General description.....</i>	<i>Pag. 2</i>
Componenti e Sigle.....	Pag. 3
<i>Components and Types.....</i>	<i>Pag. 3</i>
Versioni tra due Alberi.....	Pag. 4
<i>Shafts to Shafts Versions.....</i>	<i>Pag. 4</i>
Versioni a Parete.....	Pag. 5
<i>Flange Mounting Versions.....</i>	<i>Pag. 5</i>
Versioni Speciali.....	Pag. 6
<i>Special Mounting Versions.....</i>	<i>Pag. 6</i>
Dimensionamento.....	Pag. 7
<i>Dimensioning.....</i>	<i>Pag. 7</i>
Tabella Fori e Cave.....	Pag. 22
<i>Bore and Keyway Dimensions Table.....</i>	<i>Pag. 22</i>
Errori di Allineamento Max Ammissibili.....	Pag. 23
<i>Maximum admitted allignments errors.....</i>	<i>Pag. 23</i>
Montaggio giunto rotoflexi.....	Pag. 24
<i>Mounting rotoflexi flexible coupling.....</i>	<i>Pag. 24</i>

Il Giunto Rotoflexi è costituito da una serie di tasselli metallici, collegati tra di loro, attraverso un rivestimento circolare in gomma con durezza 70 Shore.
 (a richiesta l'elemento elastico può essere fornito anche con materiali e durezza diverse)
 All'estremità si trova uno, o due mozzi contrapposti, in ghisa (acciaio a richiesta).
 Il tutto, assemblato con viti in acciaio ad alta resistenza, è privo di giochi ed è in grado di correggere disallineamenti assiali, radiali e angolari.
 Inoltre ha un'ottima caratteristica di assorbire strappi e vibrazioni, ciò è dovuto all'eccezionale processo di costruzione dell'anello elastico.
 Può funzionare costantemente sino a temperature di 90°C senza subire danni e mantenendo inalterate le proprie prestazioni.

*The Rotoflexi Coupling is consisting of a set metallic dowels connected amongst then through a rubber circular coating with harness 70 Shore.
 (on request the elastic element can be supplied also with material and different hardnesses)
 To the external side there is one or two counter-opposed hubs, made of caston iron.
 The whole unit, assempled with stainless stell screws at high resistance, is gap-less and it is in the position to adjust axial disalignments, radial and angular.
 Besides it has a realiable caracteristic to absorb shocks and vibrations, due to the special construction process of the elastic ring.
 It can work costantly up to a temperature of 90°C without receive damages and keeping inalterate its performances.*

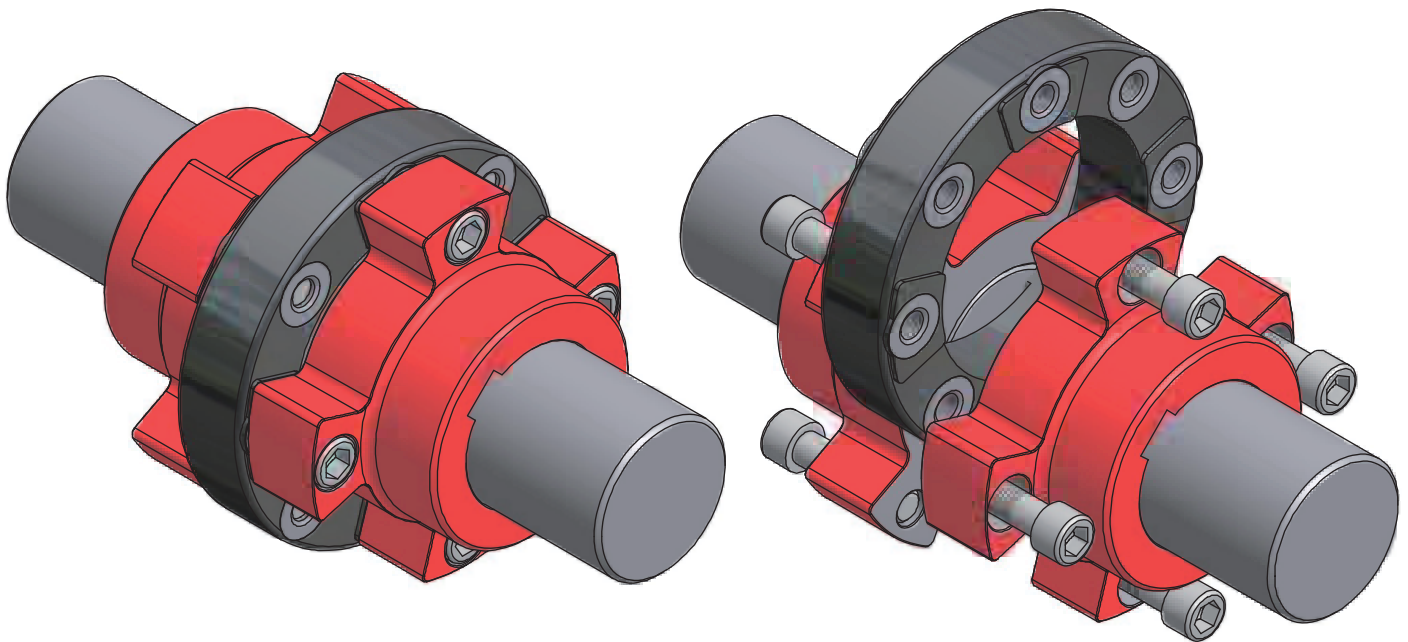

- Rapida Sostituzione dell'elemento in gomma senza spostamento assiale dei mozzi.
- Correzione di qualunque errore di allineamento.
- Assorbimento delle vibrazioni torsionali.
- Elevata resistenza meccanica.
- Riduzione degli ingombri.
- Versatilità di montaggi.
- Ampio angolo di torsione.
- Trasmissione della coppia senza giochi meccanici di centraggio.
- Isolamento elettrico ed elettrostatico.
- Nessuna manutenzione.
- Facilità di allineamento senza l'uso di strumenti.

- Quick replacement of the rubber element without axial movement of the hubs.
- Adjusment of every allignments error.
- Absorbition of the torsional vibrations.
- High mechanical resistance.
- Reduction of the dimentions.
- Assembling versatility.
- Large torsional angle.
- Transmission of the couple without mechanical centering gaps.
- Electrostatic and electrical insulation.
- No maintenance.
- Easy alignment without use of instruments.

MONTAGGIO FRA DUE ALBERI
MOUNTING AMONGST TWO SHAFTS

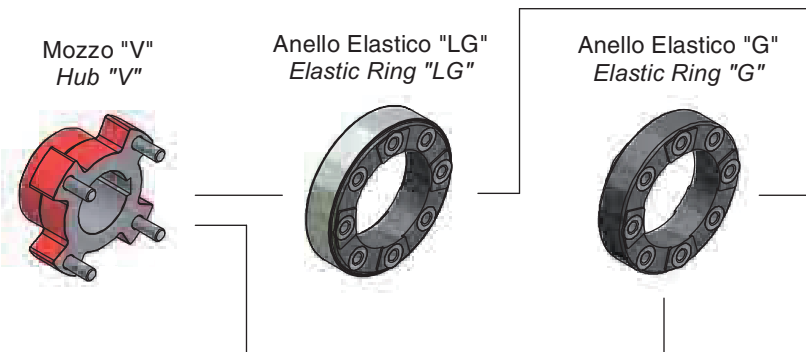

MONTAGGIO A PARETE
FLANGE MOUNTING

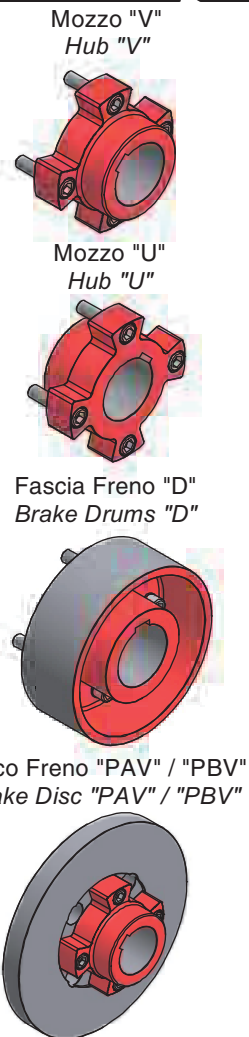
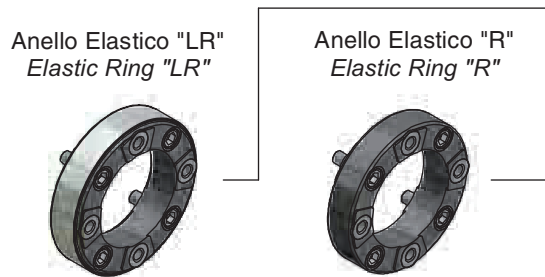

Grandezze Size	Denominazione Componenti					Components Denomination				
	V	LG	G	LR	R	V	U	D	PAV	PBV
1	V1	LG1	G1	LR1	R1	V1	U1	D1	PAV1	PBV1
2	V2	LG2	G2	LR2	R2	V2	U2	D2	PAV2	PBV2
3	V3	LG3	G3	LR3	R3	V3	U3	D3	PAV3	PBV3
4	V4	LG4	G4	LR4	R4	V4	U4	D4	PAV4	PBV4
5	V5	LG5	G5	LR5	R5	V5	U5	D5	PAV5	PBV5
6	V6	LG6	G6	LR6	R6	V6	U6	D6	PAV6	PBV6
7	V7	LG7	G7	LR7	R7	V7	U7	D7	PAV7	PBV7
8	V8	LG8	G8	LR8	R8	V8	U8	D8	PAV8	PBV8

Composizione Sigla Composition of the type

Esempio d'ordinazione Example how to order						
V	G	D	5	315	ø24	ø48
Terminal - V - U - D - PAV - PBV		Terminal - V - U - D - PAV - PBV		Terminal (amongst two shafts) - V		
Anello Elastico - G - LG - R - LR		Elastic ring - G - LG - R - LR				
Grandezza - 1 - 2 - 3 - 4 - 5 - 6 - 7 - 8		Size - 1 - 2 - 3 - 4 - 5 - 6 - 7 - 8				
Diametro Esterno del Terminale (solo per PAV-PBV-D)		External Diameter of the terminal (only for PAV-PBV-D)				
1° Foro del Terminale		1° Terminal hole				
2° Foro del Terminale		2° Terminal hole				

Tipo "G / LG"
Type "G / LG"
Pag. 8



Giunto elastico semplice con fori filettati
Simple flexible coupling with threaded holes

Tipo "VGU / VLGU"
Type "VGU / VLGU"
Pag. 12

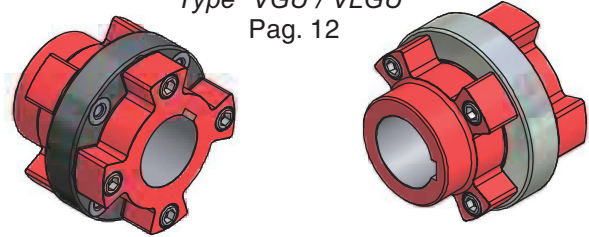

Giunto elastico con un mozzo esterno "V"
ed un mozzo incassato "U"
Flexible coupling with one external "V"
and one internal "U" hub

Tipo "GU / LGU"
Type "GU / LGU"
Pag. 9

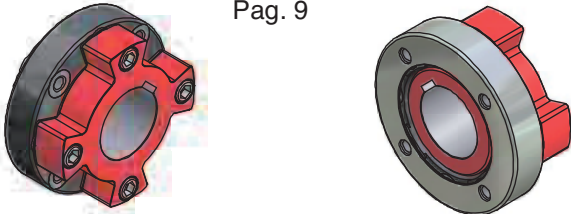

Giunto elastico con mozzo incassato "U"
Flexible coupling with internal "U" hub

Tipo "VGV / VLGV"
Type "VGV / VLGV"
Pag. 13

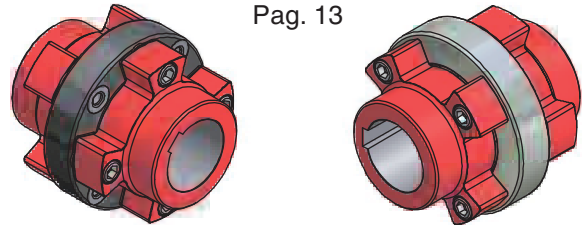

Giunto elastico con due mozzi esterni "V"
Flexible coupling with two external "V" hubs

Tipo "GV / LGV"
Type "GV / LGV"
Pag. 10



Giunto elastico con mozzo esterno "V"
Flexible coupling with external "V" hub

Tipo "VGPAV / VLGPAV"
Type "VGPAV / VLGPAV"
Pag. 14

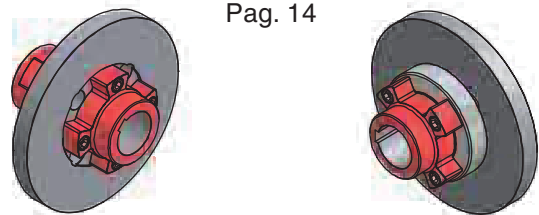

Giunto elastico con due mozzi esterni "V"
e Disco Freno "PA"
Flexible coupling with two external "V" hubs
and Brake Disc "PA"

Tipo "VGD / VLGD"
Type "VGD / VLGD"
Pag. 11



Giunto elastico con mozzo esterno "V"
e Fascia Freno "D"
Flexible coupling with external "V" hub
and Brake Drums "D"

Tipo "VGPBV / VLGPBV"
Type "VGPBV / VLGPBV"
Pag. 15

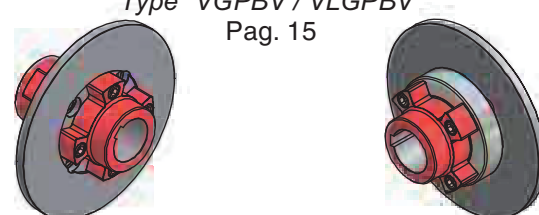

Giunto elastico con due mozzi esterni "V"
e Disco Freno "PB"
Flexible coupling with two external "V" hubs
and Brake Disc "PB"

Tipo "R / LR"
Type "R / LR"
Pag. 16



Giunto elastico con viti incassate per fissaggio a parete
Flexible coupling with screws for flange connection

Tipo "RD / LRD"
Type "RD / LRD"
Pag. 19

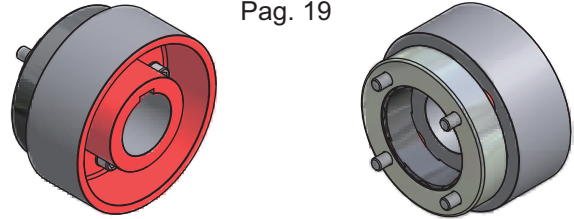

Giunto elastico per fissaggio a parete con Fascia Freno "D"
Flexible coupling for flange connection with Brake Drums "D"

Tipo "RU / LRU"
Type "RU / LRU"
Pag. 17

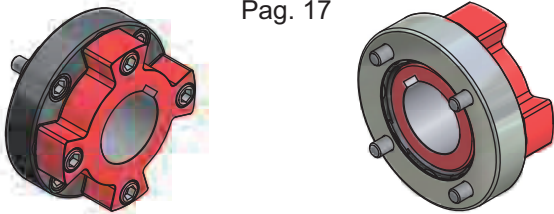

Giunto elastico per fissaggio a parete con mozzo incassato "U"
Flexible coupling for flange connection with internal "U" hub

Tipo "RPAV / LRPAV"
Type "RPAV / LRPAV"
Pag. 20

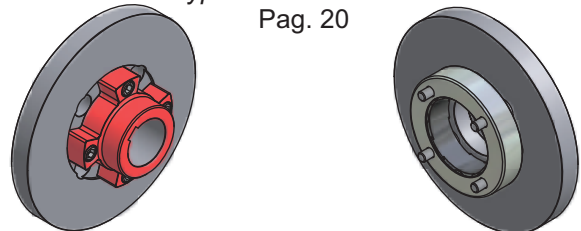

Giunto elastico per fissaggio a parete con Disco Freno "PA"
Flexible coupling for flange connection with Brake Disc "PA"

Tipo "RV / LRV"
Type "RV / LRV"
Pag. 18

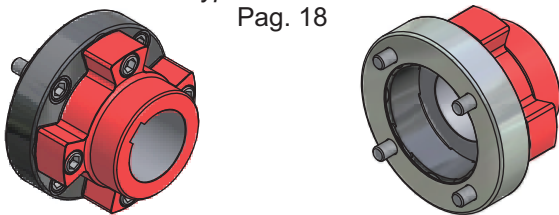

Giunto elastico per fissaggio a parete con mozzo esterno "V"
Flexible coupling for flange connection with external "V" hub

Tipo "RPBV / LRPBV"
Type "RPBV / LRPBV"
Pag. 21

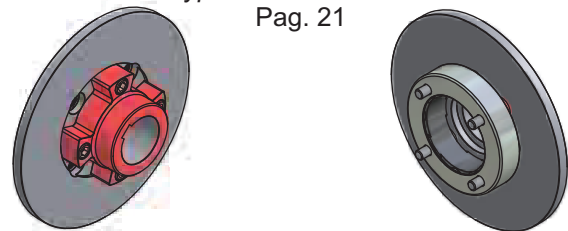

Giunto elastico per fissaggio a parete con Disco Freno "PB"
Flexible coupling for flange connection with Brake Disc "PB"

VERSIONI PER ALLUNGHE
VERSIONS FOR EXTENTIONS

Tipo "LRU"
Type "LRU"

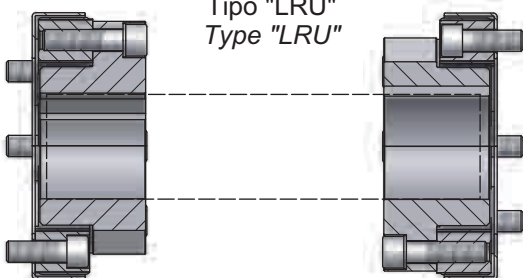

Tipo "VLGU"
Type "VLGU"

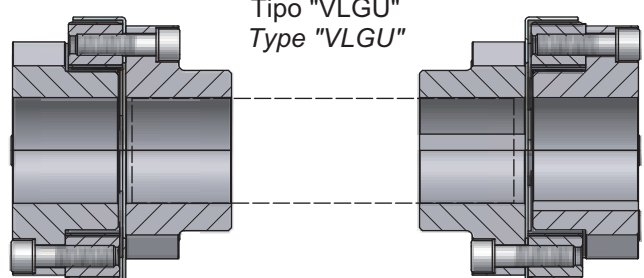

Per Dimensioni e Caratteristiche Tecniche, contattare il ns. Ufficio Tecnico
For Dimensions and Technical specifications please contact our Technical Dept

Esecuzione "PARALLELA"
"PARALLEL" Execution

In questa esecuzione vengono accoppiati due elementi elastici in modo da costituire un unico elemento di sezione doppia. Ciò permette di raddoppiare il valore della coppia trasmissibile.

In this execution are coupled two elastic elements in order to form one only element of double section. This allows to double the value of the trasmissible torque.

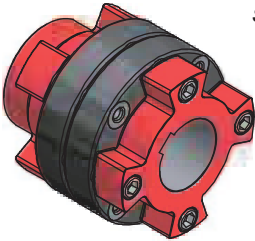

Tipo "VGGU" con due elementi elastici
Type "VGGU" with two elastic elements

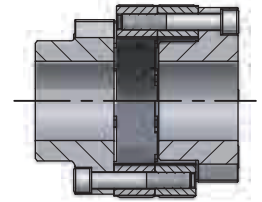

Esecuzione "IN SERIE"
"MASS" Execution

In questa esecuzione si possono accoppiare due o più elementi elastici in modo da ottenere una maggiore flessibilità. Ciò permette un maggior errore d'allineamento degli alberi e minor deformazione dell'elemento elastico, garantendo un'ottima durata. Inoltre si ottiene una riduzione del carico radiale sui supporti e un maggior assorbimento degli urti.

With this execution it is possible to couple two or more elastic elements in order to obtain a better flexibility. This allows an high error of the alignments of the shafts and less deformation of the elastic element which guaranty a long life. Besides it is obtained a reduction of the radial load on the supports and more shocks absorbtion.

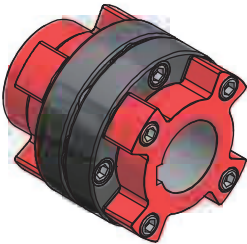

Tipo "VS(2)GU" con due elementi elastici
Type "VS(2)GU" with two elastic elements

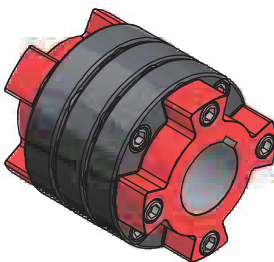
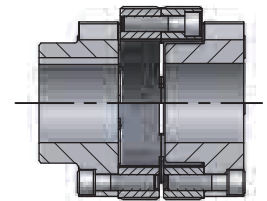

Tipo "US(3)GU" con tre elementi elastici
Type "US(3)GU" with three elastic elements

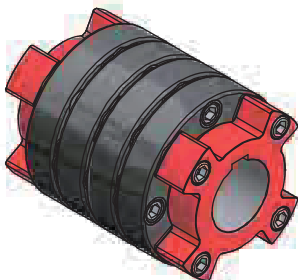
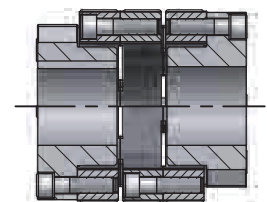

Tipo "US(4)GU" con quattro elementi elastici
Type "US(4)GU" with four elastic elements

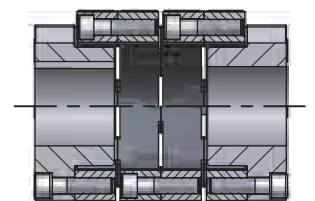

Per Dimensioni e Caratteristiche Tecniche, contattare il ns. Ufficio Tecnico
For Dimensions and Technical specifications please contact our Technical Dept

Nella scelta del Giunto Elastico si deve considerare la Potenza da trasmettere e i giri dell'albero su cui viene montato il giunto stesso.

$$Mt = \frac{P(Kw) \times 974 \times 9.81}{\text{giri/minuto}}$$

oppure

$$Mt = \frac{P(Cv) \times 716 \times 9.81}{\text{giri/minuto}}$$

Si ottiene il Momento Torcente in Nm.

In base al tipo di comando e alla durata del servizio il Mt si moltiplica per il "Fattore di Servizio" (vedi Tabella 2) e si ottiene il momento torcente nominale con il quale si sceglie la grandezza del Giunto Elastico.

To select the Elastic Coupling you must consider the power to be transmitted and the shaft's r.p.m. on which the same Coupling is installed.

$$Mt = \frac{P(Kw) \times 974 \times 9.81}{r.p.m. / min}$$

or

$$Mt = \frac{P(Cv) \times 716 \times 9.81}{r.p.m. / min}$$

it is obtained the Torque Moment in Nm.

According to the type of drive and to the service time the Mt is multiplied for the "Service Factor" (see Table 2) obtaining the nominal torque moment necessary to choose the size of the elastic Coupling.

Fattori di Servizio "K"
"K" Service Factors

Tabella 2
Table 2

Grand Size	Coppia / Torque	
	Nominale Nm Nominal Nm	Max Nm
1	25	50
2	65	130
3	175	350
4	330	660
5	440	880
6	630	1260
7	1160	2320
8	2000	4000

Tipo di Comando Type of Drive	Durata del Servizio Service Time	Tipo di Carico Type of Load		
		Uniforme Evenly	Urti Moderati Moderate Shocks	Urti Forti Strong Shocks
Motore Elettrico Electric Motor	Da 1 a 3 ore/giorno From 1 to 3 hours/day	1	1.5	2
	Fino 10 ore/giorno Upto 10 hours/day	1.5	2	2.5
	24 ore/giorno 24 hours/day	1.75	2.5	3
Motore a Combustione interna Pluricilindrico Pluricylinder Internal Combustion Motor	Da 1 a 3 ore/giorno From 1 to 3 hours/day	1.5	1.75	2
	Fino 10 ore/giorno Upto 10 hours/day	1.75	2	2.5
	24 ore/giorno 24 hours/day	2	2.5	3
Motore a Combustione interna Monocilindrico Singlecylinder Internal Combustion Motor	Da 1 a 3 ore/giorno From 1 to 3 hours/day	1.75	2	2.5
	Fino 10 ore/giorno Upto 10 hours/day	2	2.5	3
	24 ore/giorno 24 hours/day	2.5	3	3.5



Tipo "G"
Type "G"

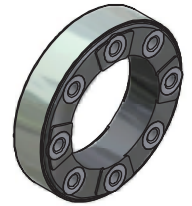

Tipo "LG"
Type "LG"

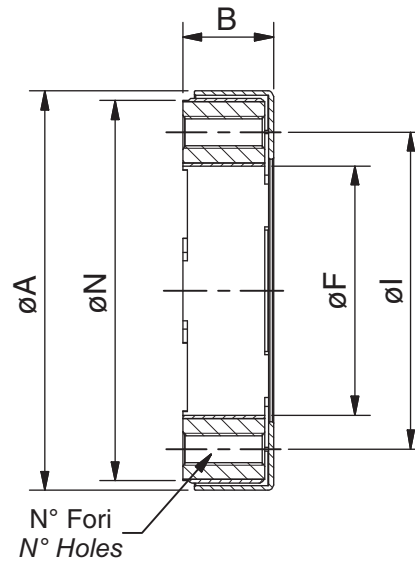
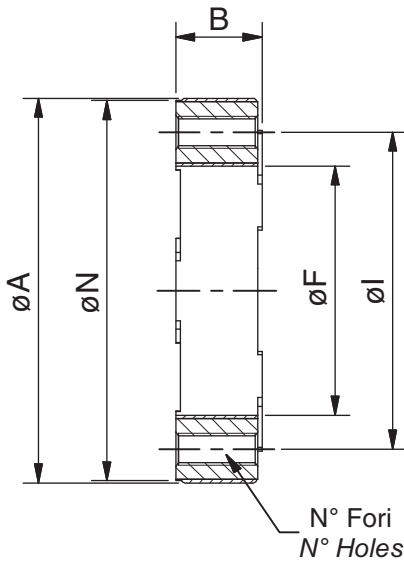

Solo per LG8
Only for LG8

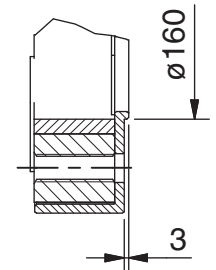

Dimensioni mm Dimensions mm

Grand Size	Tipo Type	Coppia Torque Nm	n°Max giri/1' r.p.m.	$\varnothing A$	B	$\varnothing F$	$\varnothing l$	$\varnothing N$	Fori Holes		Peso Weight Kg.	Inerzia Inertia Kgm2
									N°	\varnothing		
1	G1	25	6500	80	18	45	60	75	3+3	M8	0.1	0.0001
	LG1			84	20						0.2	0.0003
2	G2	65	5500	100	22	52	78	94	3+3	M8	0.3	0.0005
	LG2			104	24						0.5	0.0009
3	G3	175	5000	126	30	72	100	120.8	4+4	M10	0.7	0.0017
	LG3			130	32						0.9	0.0027
4	G4	330	4000	153	34	95	125	143	4+4	M12	1.1	0.0043
	LG4			158	36						1.5	0.0064
5	G5	440	3500	170	38	110	140	163	4+4	M14	1.5	0.0074
	LG5			176	40						2	0.0107
6	G6	630	3000	190	42	125	160	182	4+4	M14	1.8	0.0115
	LG6			195	44						2.4	0.0166
7	G7	1160	2500	232	48	150	195	224	4+4	M16	3.4	0.0323
	LG7			236	50						4.2	0.0428
8	G8	2000	2000	271	56	160	225	263	4+4	M18	6.6	0.0833
	LG8			285	62						10.9	0.1535

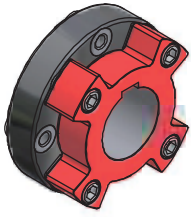

Tipo "GU"
Type "GU"

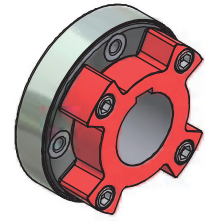

Tipo "LGU"
Type "LGU"

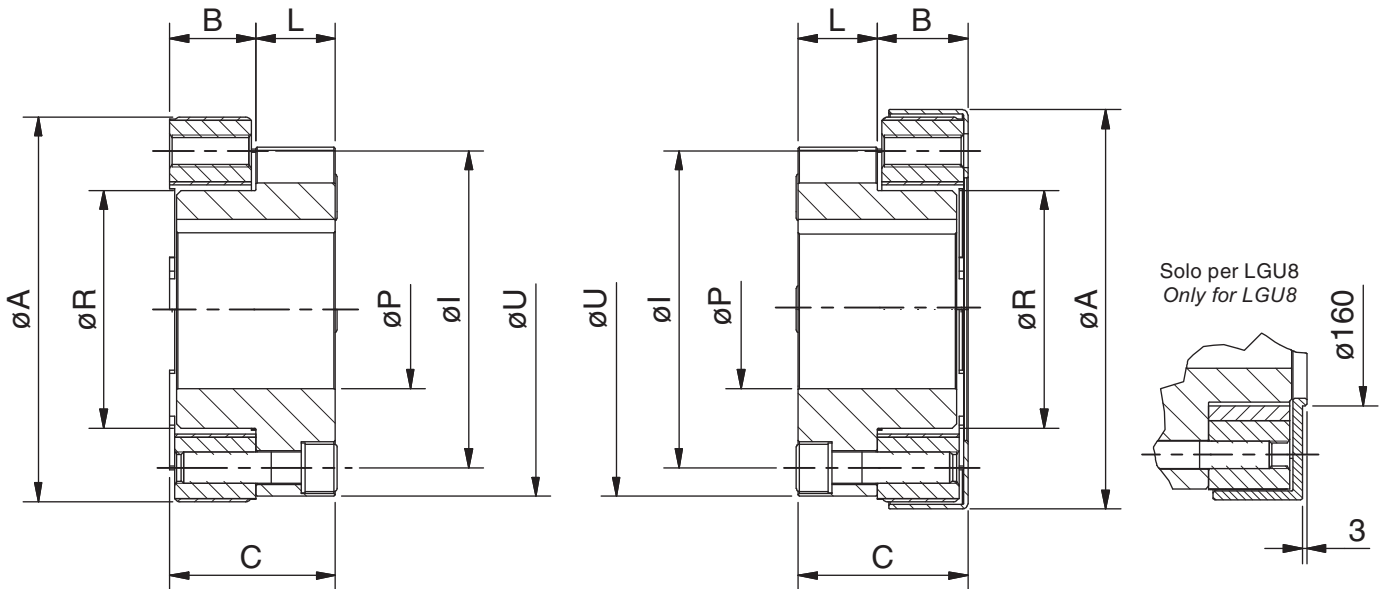

NOTE:

1. A richiesta foro øP lavorato
Upon request bore øP machined
2. Per dimensioni foro e cava vedere tabella Pag. 22
For bore and keyway dimensions see sheet Pag. 22

Dimensioni mm Dimensions mm

Grand Size	Tipo Type	Coppia Torque Nm	n°Max giri/1' r.p.m.	øA	B	C	øI	L	øP Max	øR	øU	Peso Weight Kg.	Inerzia Inertia Kgm2
1	GU1	25	6500	80	18	33	60	15	24	44	77	0.5	0.0003
	LGU1			84	20	35						0.6	0.0005
2	GU2	65	5500	100	22	47	78	25	32	50	94	1.1	0.0012
	LGU2			104	24	49						1.3	0.0016
3	GU3	175	5000	126	30	60	100	30	48	70	118	2.1	0.0038
	LGU3			130	32	62						2.4	0.0048
4	GU4	330	4000	153	34	64	125	30	60	90	147	3.5	0.0096
	LGU4			158	36	66						3.9	0.0117
5	GU5	440	3500	170	38	73	140	35	70	105	165	5.1	0.0177
	LGU5			176	40	75						5.6	0.0209
6	GU6	630	3000	190	42	82	160	40	80	120	185	7.2	0.0312
	LGU6			195	44	84						7.9	0.0364
7	GU7	1160	2500	232	48	93	195	45	100	145	226	12	0.0803
	LGU7			236	50	95						13	0.0905
8	GU8	2000	2000	271	56	111	225	55	110	155	270	20.5	0.1892
	LGU8			285	62	117						24.8	0.2594

Peso e Inerzia sono riferiti al Giunto completo con Foro Max
Weight and Inertia values refer to the complete Coupling with max bore

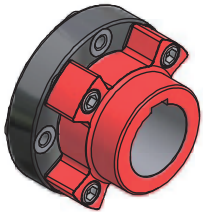

Tipo "GV"
Type "GV"

Tipo "LGV"
Type "LGV"

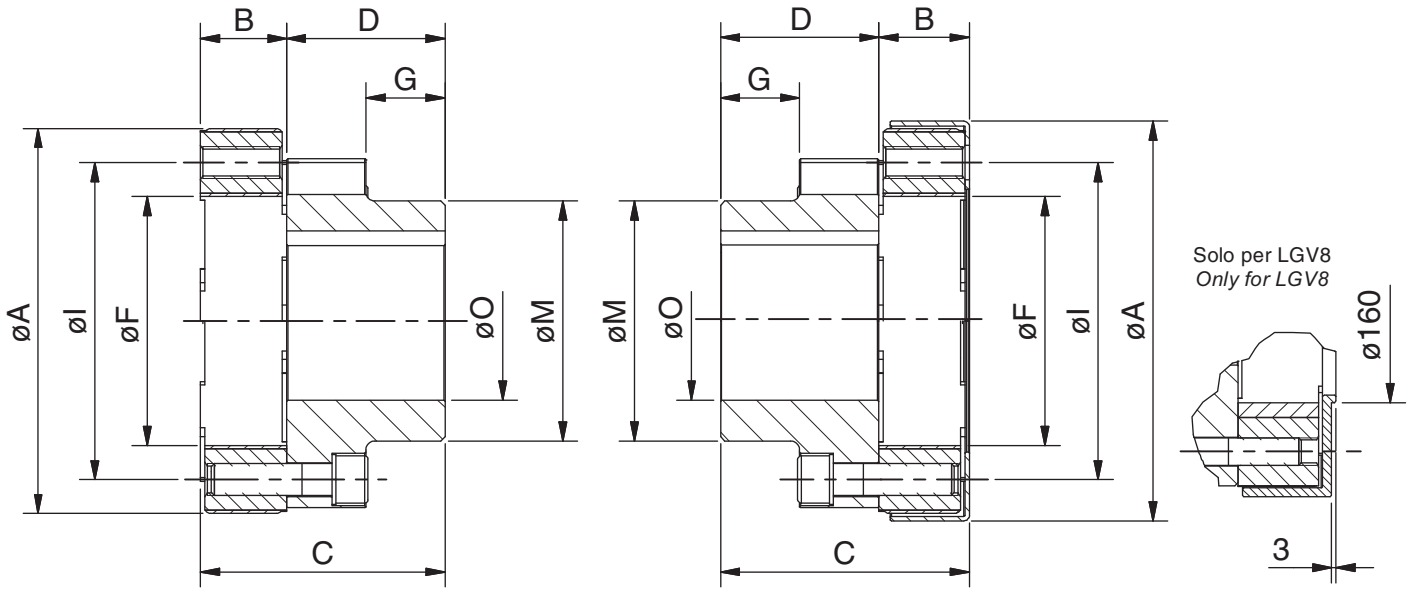
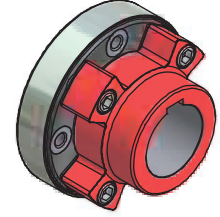

NOTE:

1. A richiesta foro $\varnothing O$ lavorato
Upon request bore $\varnothing O$ machined
2. Per dimensioni foro e cava vedere tabella Pag. 22
For bore and keyway dimensions see sheet Pag. 22

Dimensioni mm Dimensions mm

Grand Size	Tipo Type	Coppia Torque Nm	n°Max giri/1' r.p.m.	$\varnothing A$	B	C	D	$\varnothing F$	G	$\varnothing I$	$\varnothing M$	$\varnothing O$ Max	Peso Weight Kg.	Inerzia Inertia Kgm2
1	GV1	25	6500	80	18	48	30	45	15	60	45	28	0.5	0.0003
	LGV1			84	20	50							0.6	0.0005
2	GV2	65	5500	100	22	67	45	52	20	78	56	38	1	0.0011
	LGV2			104	24	69							1.2	0.0015
3	GV3	175	5000	126	30	85	55	72	25	100	68	48	2	0.0038
	LGV3			130	32	87							2.3	0.0048
4	GV4	330	4000	153	34	94	60	95	30	125	91	60	3.5	0.0097
	LGV4			158	36	96							4	0.0118
5	GV5	440	3500	170	38	108	70	110	35	140	106	70	5.2	0.0178
	LGV5			176	40	110							5.6	0.0211
6	GV6	630	3000	190	42	122	80	125	40	160	121	80	7.3	0.0313
	LGV6			195	44	124							7.9	0.0365
7	GV7	1160	2500	232	48	138	90	150	45	195	146	100	12.2	0.0809
	LGV7			236	50	140							13	0.0911
8	GV8	2000	2000	271	56	166	110	160	55	225	156	110	20.6	0.1898
	LGV8			285	62	172							25	0.2600

Peso e Inerzia sono riferiti al Giunto completo con Foro Max
Weight and Inertia values refer to the complete Coupling with max bore

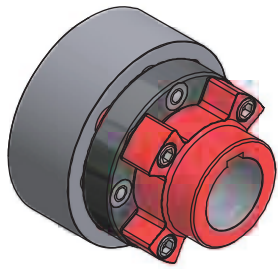

Tipo "VGD"
Type "VGD"

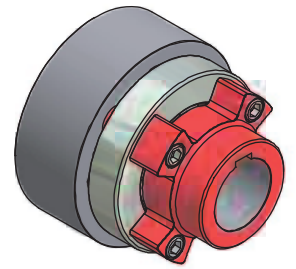

Tipo "VLGD"
Type "VLGD"

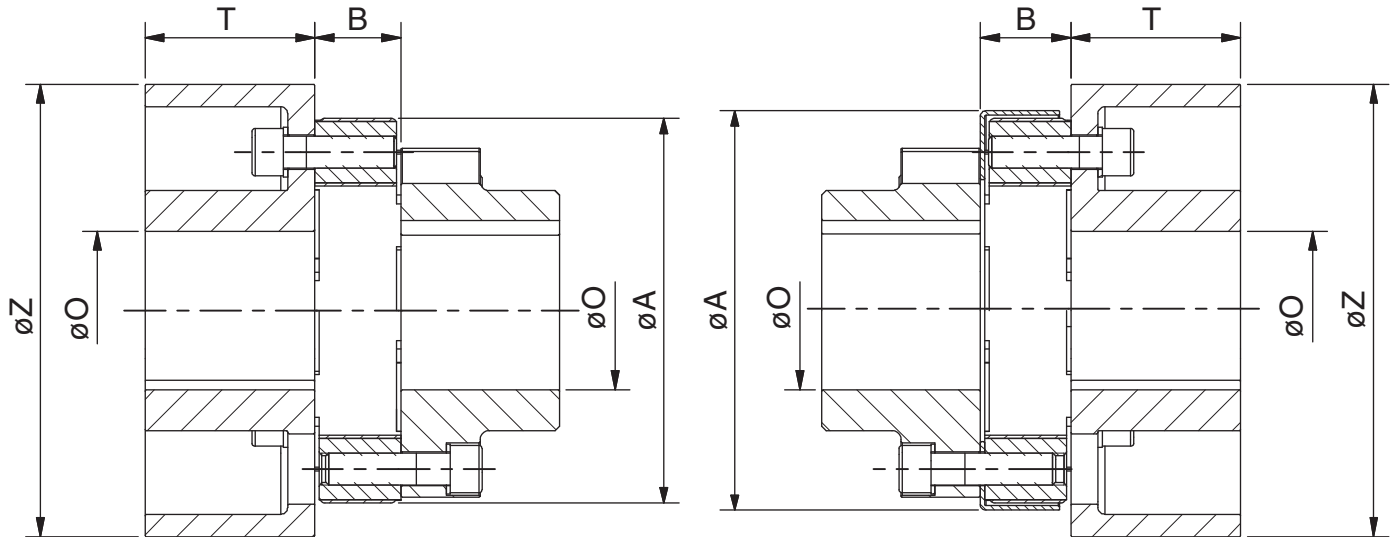

NOTA:

1. Per dimensioni Giunto elastico vedi Rotoflexi tipo "GV / LGV" a Pag. 10
For dimensions flexible Coupling see Rotoflexi type "GV / LGV" Pag. 10
2. A richiesta foro øO lavorato
Upon request bore øO machined
3. Per dimensioni foro e cava vedere tabella Pag. 22
For bore and keyway dimensions see sheet Pag. 22

FORMULA:

$$n^{\circ}\text{Max r.p.m.} = \frac{V \times 60 \times 1000}{\pi \times \phi Z} \quad \text{dove / where } V = 33 \text{ m/sec}$$

Dimensioni mm Dimensions mm

Grand Size	Tipo Type	Coppia Torque Nm	n°Max giri/' r.p.m.	øA	B	øO Max	øZ	T	Peso Weight Kg.	Inerzia Inertia Kgm2	øZ	T	Peso Weight Kg.	Inerzia Inertia Kgm2	øZ	T	Peso Weight Kg.	Inerzia Inertia Kgm2
1	--	--	--	--	--	--	--	--	--	--	--	--	--	--	--	--	--	--
	--			--	--	--	--	--	--	--	--	--	--	--	--	--	--	--
2	VGD2	65	Vedi Formula Formula See	100	22	38	160	60	4.7	0.016	200	75	7	0.040	--	--	--	--
	VLGD2			104	24	38	160	60	5	0.017	200	75	7.2	0.041	--	--	--	--
3	VGD3	175	Vedi Formula Formula See	126	30	48	160	60	6	0.019	200	75	8.3	0.043	--	--	--	--
	VLGD3			130	32	48	160	60	6.2	0.020	200	75	8.6	0.044	--	--	--	--
4	VGD4	330	Vedi Formula Formula See	153	34	60	200	75	10.5	0.051	250	95	16.4	0.133	--	--	--	--
	VLGD4			158	36	60	200	75	11	0.053	250	95	16.7	0.135	--	--	--	--
5	VGD5	440	Vedi Formula Formula See	170	38	70	200	75	12.4	0.060	250	95	18.2	0.142	315	118	28	0.374
	VLGD5			176	40	70	200	75	12.9	0.063	250	95	18.7	0.146	315	118	28.5	0.377
6	VGD6	630	Vedi Formula Formula See	190	42	80	250	95	21.5	0.161	315	118	31.5	0.394	400	150	50	1.104
	VLGD6			195	44	80	250	95	22.2	0.166	315	118	32.2	0.399	400	150	50.6	1.109
7	VGD7	1160	Vedi Formula Formula See	232	48	100	315	118	38	0.455	400	150	57	1.170	500	190	88	3.092
	VLGD7			236	50	100	315	118	38.7	0.465	400	150	57.7	1.180	500	190	89	3.103
8	VGD8	2000	Vedi Formula Formula See	271	56	110	400	150	65.7	1.284	500	190	97	3.209	--	--	--	--
	VLGD8			285	62	110	400	150	69.8	1.353	500	190	101.2	3.279	--	--	--	--

Peso e Inerzia sono riferiti al Giunto completo con Foro Max
Weight and Inertia values refer to the complete Coupling with max bore

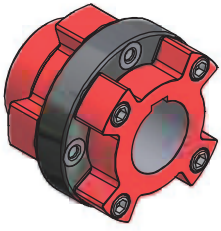

Tipo "VGU"
Type "VGU"

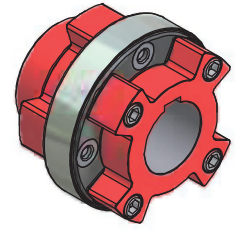

Tipo "VLGU"
Type "VLGU"

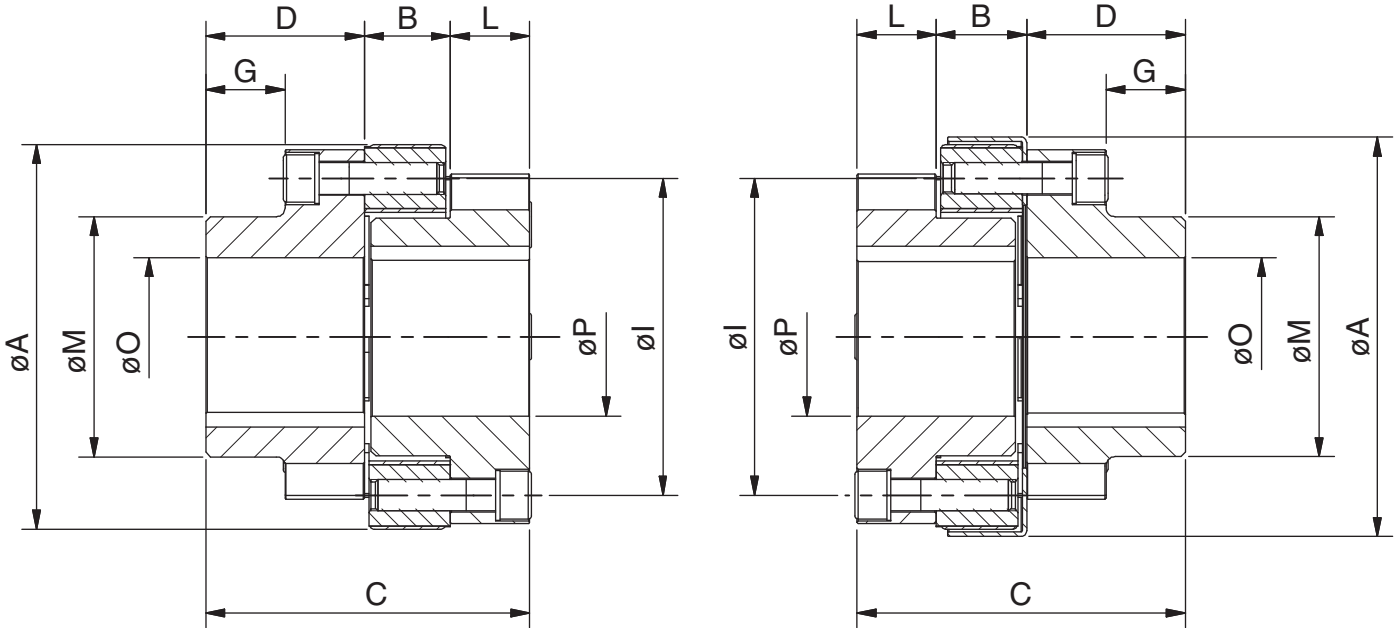

NOTE:

1. A richiesta foro $\varnothing O$ e $\varnothing P$ lavorato
Upon request bore $\varnothing O$ and $\varnothing P$ machined
2. Per dimensioni foro e cava vedere tabella Pag. 22
For bore and keyway dimensions see sheet Pag. 22

Dimensioni mm Dimensions mm

Grand Size	Tipo Type	Coppia Torque Nm	n°Max giri/1' r.p.m.	$\varnothing A$	B	C	D	G	$\varnothing I$	L	$\varnothing O$ Max	$\varnothing P$ Max	$\varnothing M$	Peso Weight Kg.	Inerzia Inertia Kgm2
1	VGU1	25	6500	80	18	63	30	15	60	15	28	24	45	0.8	0.0005
	VLGU1			84	20	65									
2	VGU2	65	5500	100	22	92	45	20	78	25	38	32	56	1.8	0.0018
	VLGU2			104	24	94									
3	VGU3	175	5000	126	30	115	55	25	100	30	48	48	68	3.5	0.0059
	VLGU3			130	32	117									
4	VGU4	330	4000	153	34	124	60	30	125	30	60	60	91	5.9	0.0150
	VLGU4			158	36	126									
5	VGU5	440	3500	175	38	143	70	35	140	35	70	70	106	8.8	0.0281
	VLGU5			176	40	145									
6	VGU6	630	3000	190	42	162	80	40	160	40	80	80	121	12.7	0.0511
	VLGU6			195	44	164									
7	VGU7	1160	2500	232	48	183	90	45	195	45	100	100	146	20.8	0.1286
	VLGU7			236	50	185									
8	VGU8	2000	2000	271	56	221	110	55	225	55	110	110	156	34.5	0.2959
	VLGU8			285	62	227									

Peso e Inerzia sono riferiti al Giunto completo con Foro Max
Weight and Inertia values refer to the complete Coupling with max bore

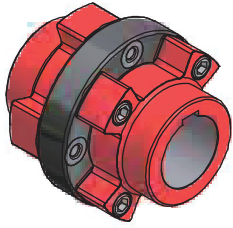

Tipo "VGV"
Type "VGV"

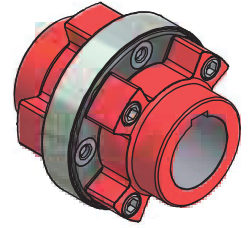

Tipo "VLGV"
Type "VLGV"

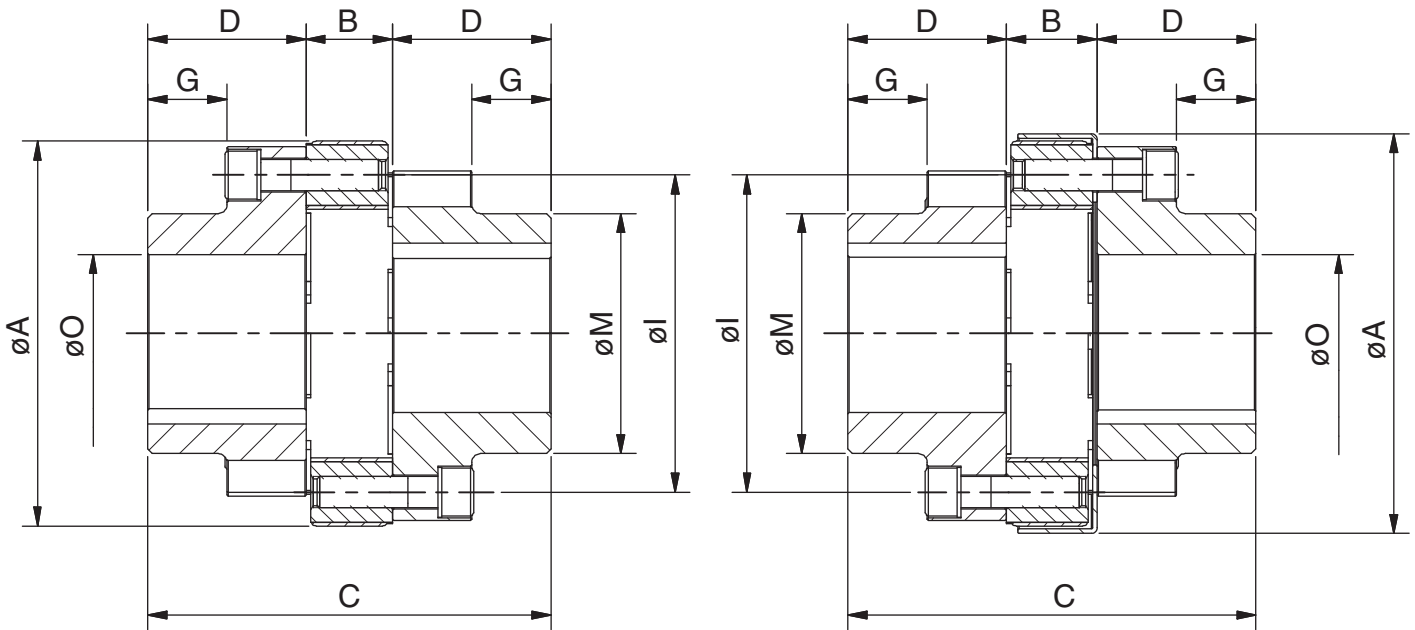

NOTE:

1. A richiesta foro $\varnothing O$ lavorato
Upon request bore $\varnothing O$ machined
2. Per dimensioni foro e cava vedere tabella Pag. 22
For bore and keyway dimensions see sheet Pag. 22

Dimensioni mm *Dimensions mm*

Grand Size	Tipo Type	Coppia Torque Nm	n°Max giri/1' r.p.m.	$\varnothing A$	B	C	D	G	$\varnothing I$	$\varnothing O$ Max	$\varnothing M$	Peso Weight Kg.	Inerzia Inertia Kgm2
1	VGV1	25	6500	80	18	78	30	15	60	28	45	0.9	0.0005
	VLGV1			84	20	80						1	0.0007
2	VGV2	65	5500	100	22	112	45	20	78	38	56	1.7	0.0017
	VLGV2			104	24	114						1.9	0.0020
3	VGV3	175	5000	126	30	140	55	25	100	48	68	3.4	0.0058
	VLGV3			130	32	142						3.7	0.0069
4	VGV4	330	4000	153	34	154	60	30	125	60	91	6	0.0151
	VLGV4			158	36	156						6.4	0.0172
5	VGV5	440	3500	170	38	178	70	35	140	70	106	8.7	0.0282
	VLGV5			176	40	180						9.3	0.0315
6	VGV6	630	3000	190	42	202	80	40	160	80	121	12.8	0.0512
	VLGV6			195	44	204						13.4	0.0563
7	VGV7	1160	2500	232	48	228	90	45	195	100	146	21	0.1291
	VLGV7			236	50	230						21.8	0.1392
8	VGV8	2000	2000	271	56	276	110	55	225	110	156	34.6	0.2963
	VLGV8			285	62	282						38.7	0.3658

Peso e Inerzia sono riferiti al Giunto completo con Foro Max
Weight and Inertia values refer to the complete Coupling with max bore

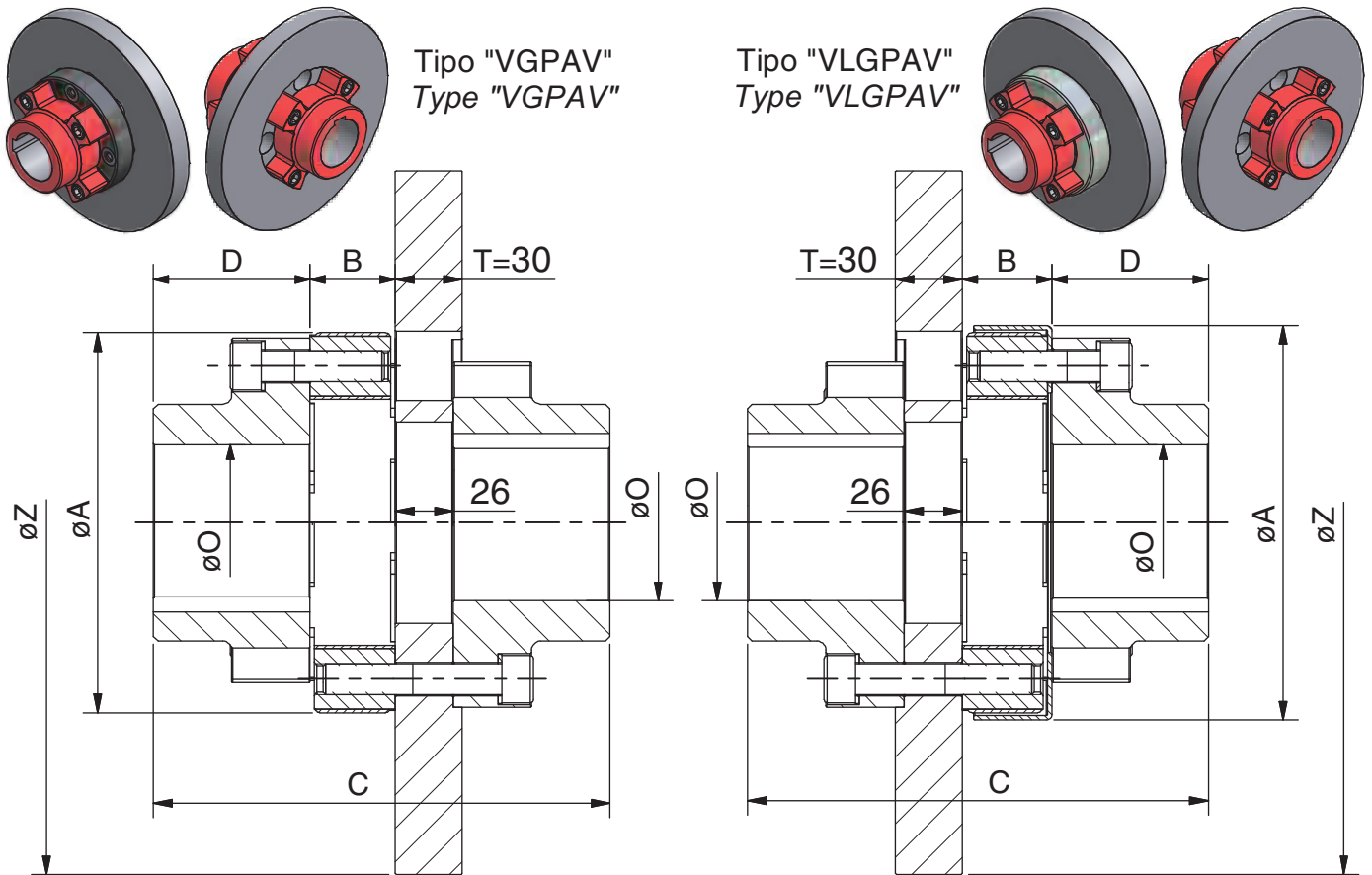

NOTA:

1. Per dimensioni Giunto elastico vedi Rotoflexi tipo "GV / LGV" a Pag. 10
For dimensions flexible Coupling see Rotoflexi type "GV / LGV" Pag. 10
2. A richiesta foro øO lavorato
Upon request bore øO machined
3. Per dimensioni foro e cava vedere tabella Pag. 22
For bore and keyway dimensions see sheet Pag. 22

FORMULA:

$$n^{\circ}\text{Max r.p.m.} = \frac{V \times 60 \times 1000}{\pi \times \varnothing Z} \text{ dove / where } V = 33 \text{ m/sec}$$

Dimensioni mm Dimensions mm

Grand Size	Tipo Type	Coppia Torque Nm	n°Max giri/1' r.p.m.	øA	B	C	D	øO Max	øZ	Peso Weight Kg.	Inerzia Inertia Kgm2	øZ	Peso Weight Kg.	Inerzia Inertia Kgm2	øZ	Peso Weight Kg.	Inerzia Inertia Kgm2
1	--	--	--	--	--	--	--	--	--	--	--	--	--	--	--	--	--
	--			--	--	--	--	--	--	--	--	--	--	--	--	--	--
2	VGPAV2	65	--	100	22	138	45	38	200	8.3	0.038	--	--	--	--	--	--
	VLGPAV2			104	24	140				8.5	0.038		--	--		--	
3	VGPAV3	175	--	126	30	166	55	48	250	13.7	0.094	315	20.5	0.231	--	--	--
	VLGPAV3			130	32	168				14	0.095		20.8	0.232		--	--
4	VGPAV4	330	--	153	34	180	60	60	250	15.5	0.101	315	22.4	0.238	--	--	--
	VLGPAV4			158	36	182				16	0.103		22.8	0.240		--	--
5	VGPAV5	440	--	170	38	204	70	70	315	24.5	0.248	355	29.5	0.388	400	35.7	0.613
	VLGPAV5			176	40	206				25	0.252		30	0.391		36.2	0.616
6	VGPAV6	630	--	190	42	228	80	80	315	27.5	0.267	355	32.5	0.407	400	38.8	0.635
	VLGPAV6			195	44	230				28.2	0.272		33.2	0.411		39.5	0.637
7	VGPAV7	1160	--	232	48	254	90	100	400	45.9	0.699	450	53.7	1.050	500	62.5	1.550
	VLGPAV7			236	50	256				46.7	0.709		54.6	1.060		63.4	1.560
8	VGPAV8	2000	--	271	56	302	110	110	500	74.4	1.701	560	86.2	2.520	630	101.5	3.890
	VLGPAV8			285	62	308				78.5	1.770		90.2	2.590		105.6	3.960

Peso e Inerzia sono riferiti al Giunto completo con Foro Max
Weight and Inertia values refer to the complete Coupling with max bore

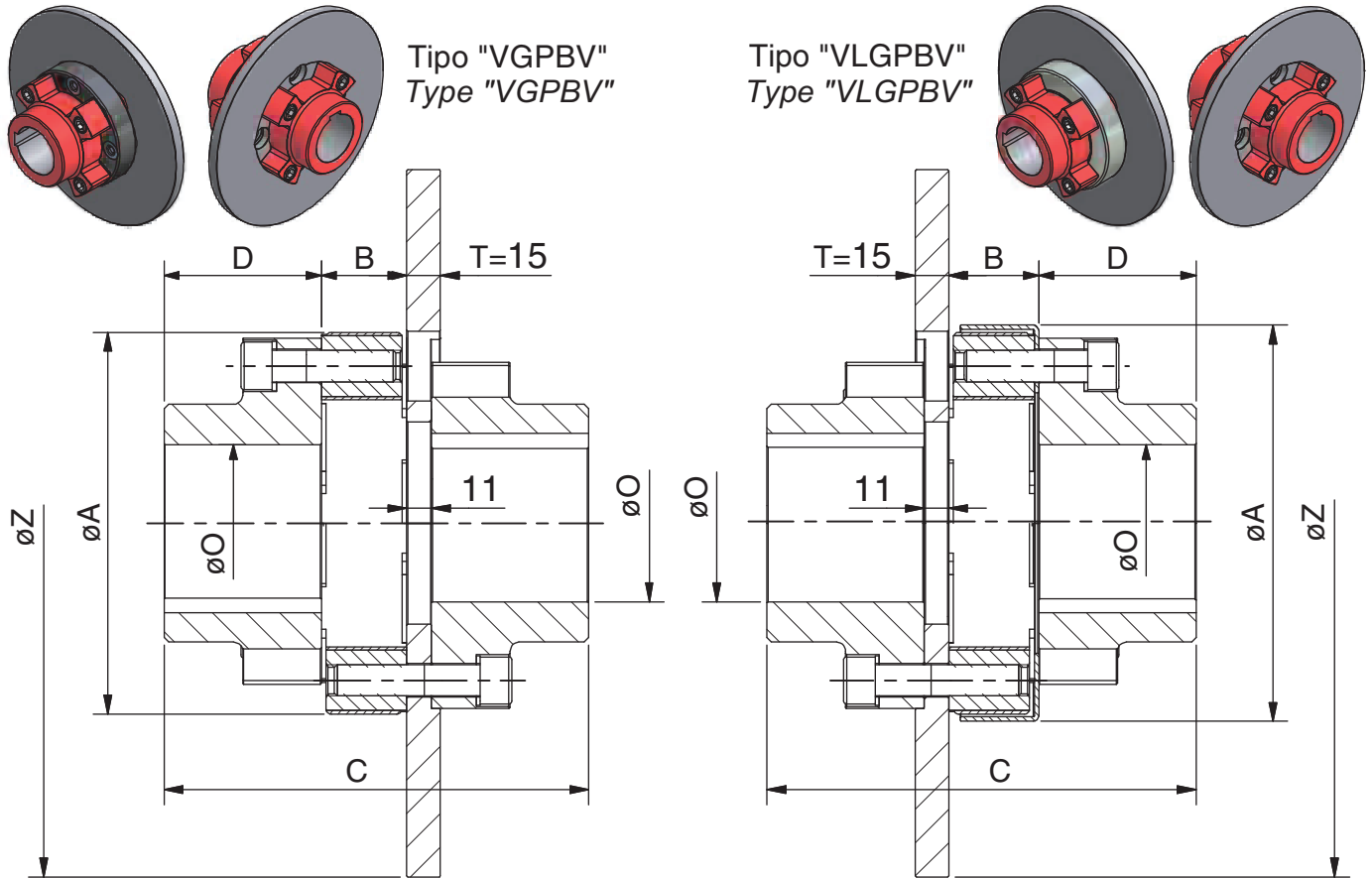

NOTA:

1. Per dimensioni Giunto elastico vedi Rotoflexi tipo "GV / LGV" a Pag. 10
For dimensions flexible Coupling see Rotoflexi type "GV / LGV" Pag. 10
2. A richiesta foro øO lavorato
Upon request bore øO machined
3. Per dimensioni foro e cava vedere tabella Pag. 22
For bore and keyway dimensions see sheet Pag. 22

FORMULA:

$$n^{\circ}\text{Max r.p.m.} = \frac{V \times 60 \times 1000}{\pi \times \varnothing Z} \text{ dove / where } V = 33 \text{ m/sec}$$

Dimensioni mm Dimensions mm

Grand Size	Tipo Type	Coppia Torque Nm	n°Max giri/1' r.p.m.	øA	B	C	D	øO Max	øZ	Peso Weight Kg.	Inerzia Inertia Kgm2	øZ	Peso Weight Kg.	Inerzia Inertia Kgm2	øZ	Peso Weight Kg.	Inerzia Inertia Kgm2
1	--	--	--	--	--	--	--	--	--	--	--	--	--	--	--	--	--
	--			--	--	--	--	--	--	--	--	--	--	--	--	--	--
2	VGPBV2	65	--	100	22	123	45	38	200	5	0.020	--	--	--	--	--	--
	VLGPBV2			104	24	125				5.1	0.020		--	--		--	
3	VGPBV3	175	--	126	30	151	55	48	250	8.5	0.050	315	11.9	0.118	--	--	--
	VLGPBV3			130	32	153				8.8	0.051		--	--		--	
4	VGPBV4	330	--	153	34	165	60	60	250	10.6	0.057	315	14	0.126	--	--	--
	VLGPBV4			158	36	167				11	0.060		--	--		--	
5	VGPBV5	440	--	170	38	189	70	70	315	16.5	0.137	355	19	0.207	400	22.1	0.320
	VLGPBV5			176	40	191				17	0.141		--	--		--	
6	VGPBV6	630	--	190	42	213	80	80	315	20	0.158	355	22.4	0.228	400	25.6	0.340
	VLGPBV6			195	44	215				20.6	0.163		--	--		--	
7	VGPBV7	1160	--	232	48	239	90	100	400	33	0.411	450	37	0.589	500	41.4	0.838
	VLGPBV7			236	50	241				33.9	0.421		--	--		--	
8	VGPBV8	2000	--	271	56	287	110	110	500	54	0.992	560	59.8	1.406	630	67.5	2.091
	VLGPBV8			285	62	293				58	1.061		--	--		--	

Peso e Inerzia sono riferiti al Giunto completo con Foro Max
Weight and Inertia values refer to the complete Coupling with max bore



Tipo "R"
Type "R"

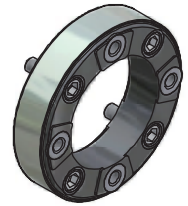

Tipo "LR"
Type "LR"

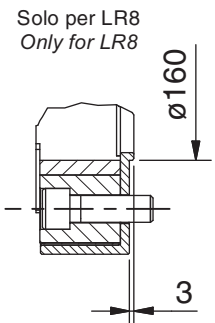
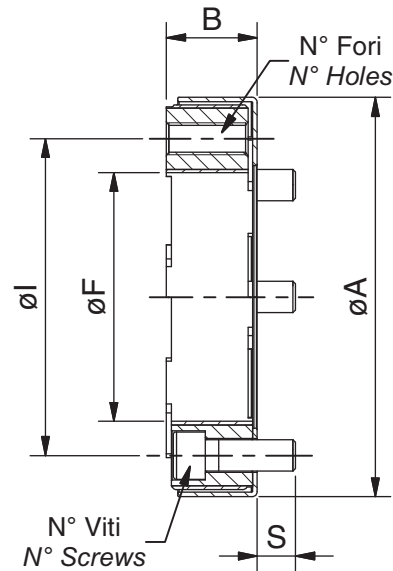
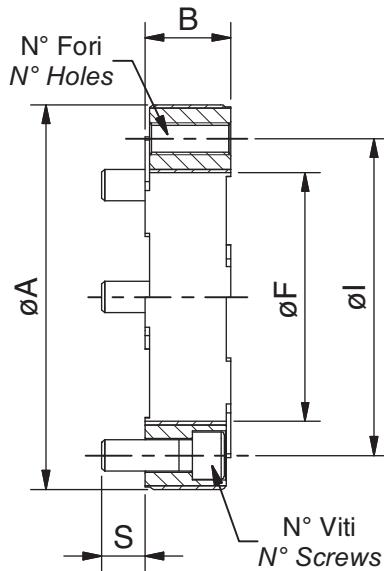

Dimensioni mm Dimensions mm

Grand Size	Tipo Type	Coppia Torque Nm	n°Max giri/1' r.p.m.	øA	B	øF	øI	S	Fori Holes		Viti Screws		Peso Weight Kg.	Inerzia Inertia Kgm2
									N°	Ø	N°	Ø		
1	R1	25	6500	80	18	45	60	10	3	M8	3	M6x20	0.1	0.0001
	LR1			84	20			8					0.2	0.0003
2	R2	65	5500	100	22	52	78	14	3	M8	3	M8x25	0.3	0.0005
	LR2			104	24			12					0.5	0.0009
3	R3	175	5000	126	30	72	100	13.5	4	M10	4	M10x30	0.6	0.0016
	LR3			130	32			16.5				M10x35	0.9	0.0026
4	R4	330	4000	153	34	95	125	16	4	M12	4	M12x35	1	0.0039
	LR4			158	36			19				M12x40	1.4	0.0061
5	R5	440	3500	170	38	110	140	19	4	M14	4	M14x40	1.3	0.0068
	LR5			176	40			22				M14x45	1.8	0.0101
6	R6	630	3000	190	42	125	160	20.5	4	M14	4	M14x45	1.6	0.0106
	LR6			195	44			23.5				M14x50	2.3	0.0158
7	R7	1160	2500	232	48	150	195	21.2	4	M16	4	M16x50	3.2	0.0311
	LR7			236	50			24.2				M16x55	4.1	0.0413
8	R8	2000	2000	271	56	160	225	26.5	4	M18	4	M18x60	6.3	0.0803
	LR8			285	62			25.5				M18x65	10.7	0.1505

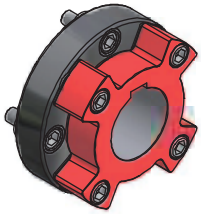

Tipo "RU"
Type "RU"

Tipo "LRU"
Type "LRU"

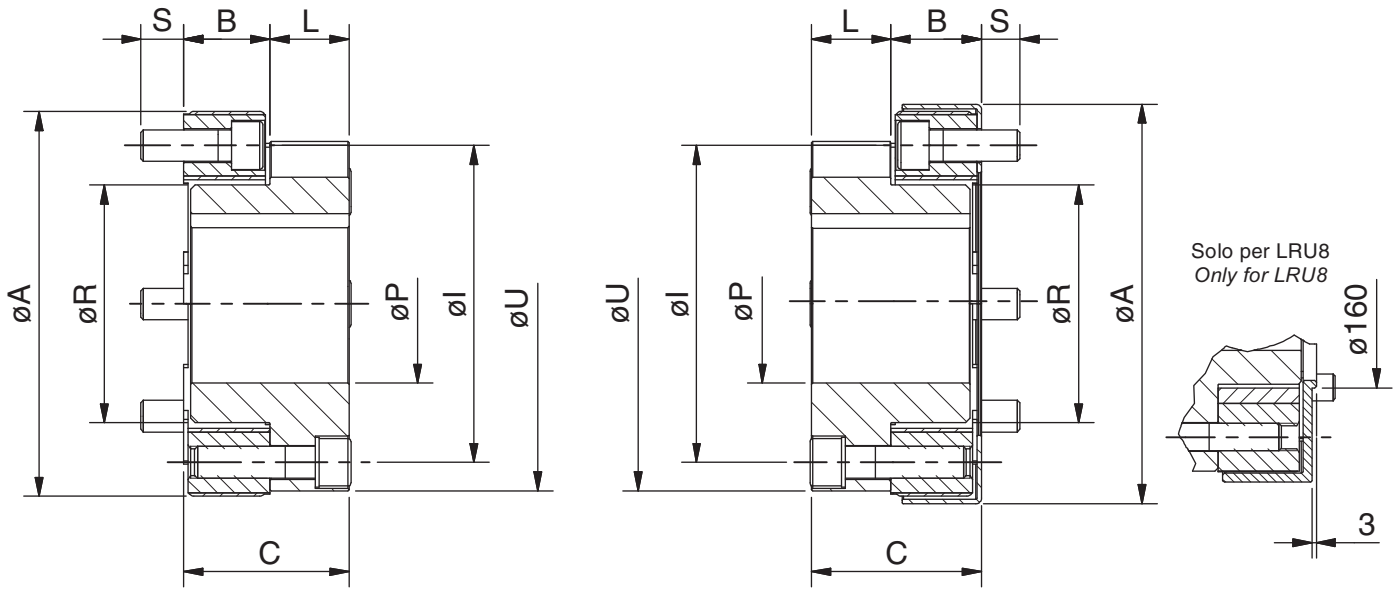
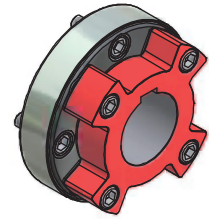

NOTE:

1. A richiesta foro øP lavorato
Upon request bore øP machined
2. Per dimensioni foro e cava vedere tabella Pag. 22
For bore and keyway dimensions see sheet Pag. 22

Dimensioni mm Dimensions mm

Grand Size	Tipo Type	Coppia Torque Nm	n°Max giri/1' r.p.m.	øA	B	C	øl	L	øP Max	øR	S	øU	Peso Weight Kg.	Inerzia Inertia Kgm2
1	RU1	25	6500	80	18	33	60	15	24	44	10	77	0.5	0.0003
	LRU1			84	20	35					8		0.6	0.0005
2	RU2	65	5500	100	22	47	78	25	32	50	14	94	1.1	0.0012
	LRU2			104	24	49					12		1.3	0.0016
3	RU3	175	5000	126	30	60	100	30	48	70	13.5	118	2.1	0.0037
	LRU3			130	32	62					16.5		2.4	0.0047
4	RU4	330	4000	153	34	64	125	30	60	90	16	147	3.4	0.0093
	LRU4			158	36	66					19		3.8	0.0113
5	RU5	440	3500	170	38	73	140	35	70	105	19	165	5	0.0170
	LRU5			176	40	75					22		5.5	0.0203
6	RU6	630	3000	190	42	82	160	40	80	120	20.5	185	7.1	0.0304
	LRU6			195	44	84					23.5		7.8	0.0355
7	RU7	1160	2500	232	48	93	195	45	100	145	21.2	226	12	0.0788
	LRU7			236	50	95					24.2		12.8	0.0889
8	RU8	2000	2000	271	56	111	225	55	110	155	26.5	270	20.2	0.1861
	LRU8			285	62	117					25.5		24.6	0.2564

Peso e Inerzia sono riferiti al Giunto completo con Foro Max
Weight and Inertia values refer to the complete Coupling with max bore

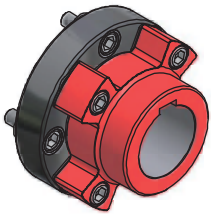

Tipo "RV"
Type "RV"

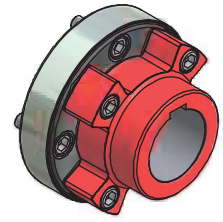

Tipo "LRV"
Type "LRV"

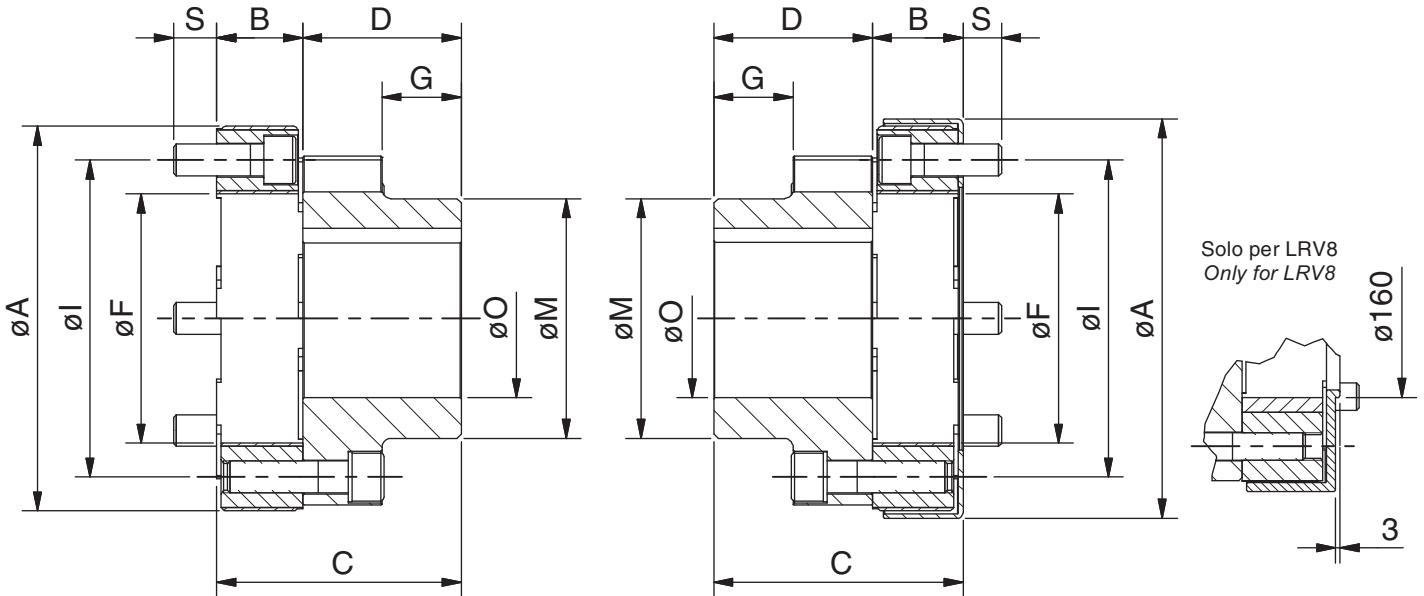

NOTE:

1. A richiesta foro øO lavorato
Upon request bore øO machined
2. Per dimensioni foro e cava vedere tabella Pag. 22
For bore and keyway dimensions see sheet Pag. 22

Dimensioni mm Dimensions mm

Grand Size	Tipo Type	Coppia Torque Nm	n°Max giri/1' r.p.m.	øA	B	C	D	øF	G	øI	øM	øO Max	S	Peso Weight Kg.	Inerzia Inertia Kgm2
1	RV1	25	6500	80	18	48	30	45	15	60	45	28	10	0.5	0.0003
	LRV1			84	20	50							8	0.6	0.0005
2	RV2	65	5500	100	22	67	45	52	20	78	56	38	14	1	0.0011
	LRV2			104	24	69							12	1.2	0.0015
3	RV3	175	5000	126	30	85	55	72	25	100	68	48	13.5	2	0.0036
	LRV3			130	32	87							16.5	2.3	0.0046
4	RV4	330	4000	153	34	94	60	95	30	125	91	60	16	3.5	0.0094
	LRV4			158	36	96							19	3.8	0.0114
5	RV5	440	3500	170	38	108	70	110	35	140	106	70	19	5	0.0172
	LRV5			176	40	110							22	5.5	0.0204
6	RV6	630	3000	190	42	122	80	125	40	160	121	80	20.5	7.1	0.0304
	LRV6			195	44	124							23.5	7.8	0.0356
7	RV7	1160	2500	232	48	138	90	150	45	195	146	100	21.2	12	0.0793
	LRV7			236	50	140							24.2	12.9	0.0895
8	RV8	2000	2000	271	56	166	110	160	55	225	156	110	26.5	20.3	0.1868
	LRV8			285	62	172							25.5	24.7	0.2570

Peso e Inerzia sono riferiti al Giunto completo con Foro Max
Weight and Inertia values refer to the complete Coupling with max bore

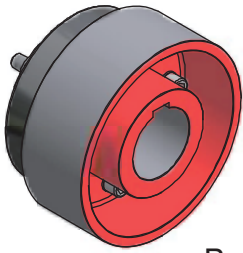

Tipo "RD"
Type "RD"

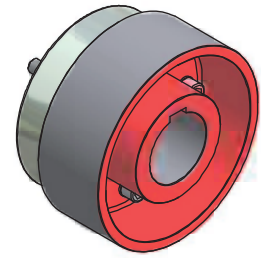

Tipo "LRD"
Type "LRD"

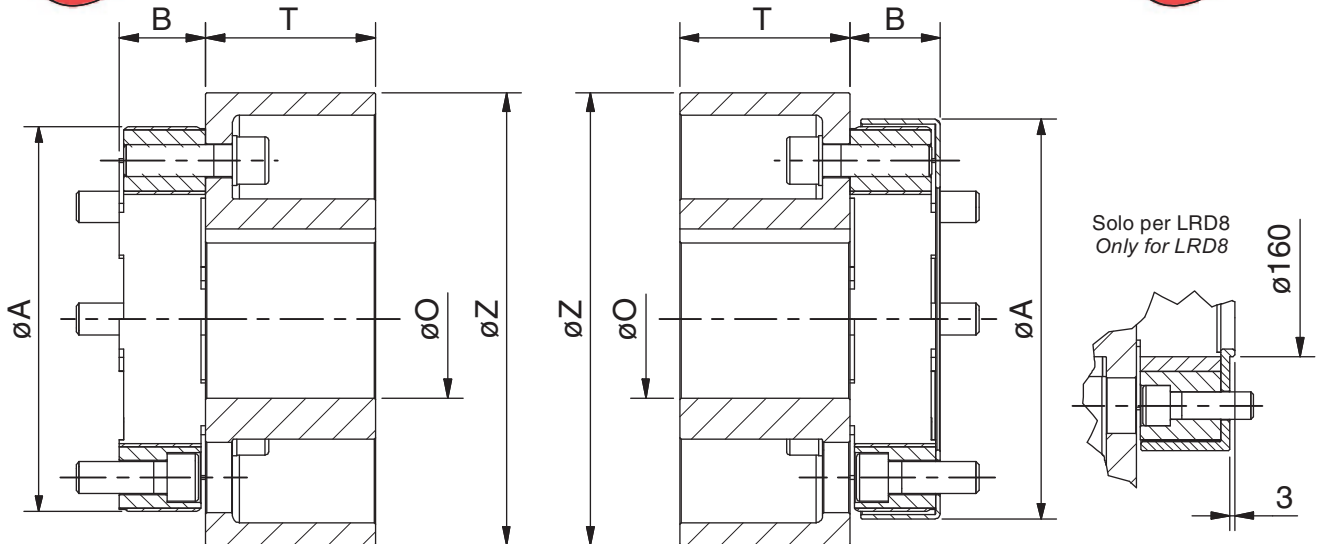

NOTA:

1. Per dimensioni Giunto elastico vedi Rotoflexi tipo "RV / LRV" a Pag. 18
For dimensions flexible Coupling see Rotoflexi type "RV / LRV" Pag. 18
2. A richiesta foro øO lavorato
Upon request bore øO machined
3. Per dimensioni foro e cava vedere tabella Pag. 22
For bore and keyway dimensions see sheet Pag. 22

FORMULA:

$$n^{\circ}\text{Max r.p.m.} = \frac{V \times 60 \times 1000}{\pi \times \phi Z} \quad \text{dove / where } V = 33 \text{ m/sec}$$

Dimensioni mm Dimensions mm

Grand Size	Tipo Type	Coppia Torque Nm	n°Max giri/1' r.p.m.	øA	B	øO Max	øZ	T	Peso Weight Kg.	Inerzia Inertia Kgm2	øZ	T	Peso Weight Kg.	Inerzia Inertia Kgm2	øZ	T	Peso Weight Kg.	Inerzia Inertia Kgm2
1	--	--	--	--	--	--	--	--	--	--	--	--	--	--	--	--	--	--
	--			--	--	--	--	--	--	--	--	--	--	--	--	--	--	--
2	RD2	65	Vedi Formula Formula See	100	22	38	160	60	4	0.016	200	75	6.3	0.040	--	--	--	--
	LRD2			104	24				4.2	0.016			6.5	0.040				
3	RD3	175	Vedi Formula Formula See	126	30	48	160	60	4.5	0.017	200	75	6.8	0.041	--	--	--	--
	LRD3			130	32				4.8	0.018			7.1	0.042				
4	RD4	330	Vedi Formula Formula See	153	34	60	200	75	8	0.045	250	95	13.8	0.127	--	--	--	--
	LRD4			158	36				8.4	0.047			14.2	0.129				
5	RD5	440	Vedi Formula Formula See	170	38	70	200	75	8.6	0.049	250	95	14.4	0.131	315	118	24.1	0.363
	LRD5			176	40				9	0.052			14.9	0.135			24.6	0.366
6	RD6	630	Vedi Formula Formula See	190	42	80	250	95	15.9	0.140	315	118	26	0.373	400	150	44.4	1.083
	LRD6			195	44				16.5	0.145			26.6	0.378			45	1.088
7	RD7	1160	Vedi Formula Formula See	232	48	100	315	118	29	0.405	400	150	48	1.120	500	190	79	3.043
	LRD7			236	50				29.8	0.415			48.7	1.130			80	3.053
8	RD8	2000	Vedi Formula Formula See	271	56	110	400	150	51.4	1.175	500	190	82.8	3.100	--	--	--	--
	LRD8			285	62				55.7	1.245			87	3.170				

Peso e Inerzia sono riferiti al Giunto completo con Foro Max
Weight and Inertia values refer to the complete Coupling with max bore

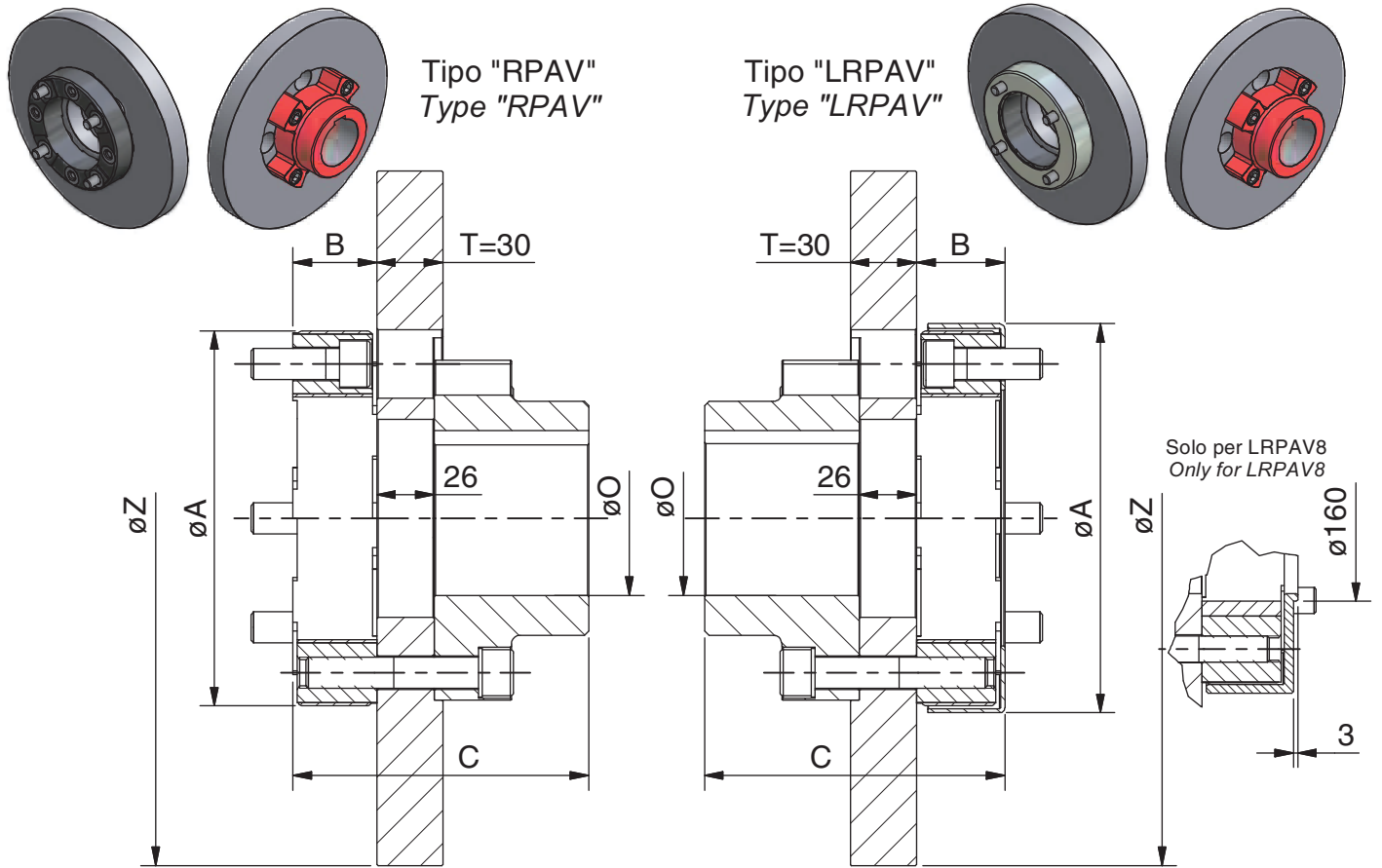

NOTA:

1. Per dimensioni Giunto elastico vedi Rotoflexi tipo "RV / LRV" a Pag. 18
For dimensions flexible Coupling see Rotoflexi type "RV / LRV" Pag. 18
2. A richiesta foro ØO lavorato
Upon request bore ØO machined
3. Per dimensioni foro e cava vedere tabella Pag. 22
For bore and keyway dimensions see sheet Pag. 22

FORMULA:

$$n^{\circ}\text{Max r.p.m.} = \frac{V \times 60 \times 1000}{\pi \times \varnothing Z} \quad \text{dove / where } V = 33 \text{ m/sec}$$

Dimensioni mm Dimensions mm

Grand Size	Tipo Type	Coppia Torque Nm	n°Max giri/1' r.p.m.	ØA	B	C	ØO Max	ØZ	Peso Weight Kg.	Inerzia Inertia Kgm2	ØZ	Peso Weight Kg.	Inerzia Inertia Kgm2	ØZ	Peso Weight Kg.	Inerzia Inertia Kgm2	
1	--	--	Vedi Formula Formula See	--	--	--	--	--	--	--	--	--	--	--	--	--	
	--	--		--	--	--	--	--	--	--	--	--	--	--	--	--	--
2	RPAV2	65		100	22	93	38	200	7.6	0.034	--	--	--	--	--	--	--
	LRPAV2			104	24	95			7.8	0.038							
3	RPAV3	175		126	30	111	48	250	12.3	0.092	315	19	0.229	--	--	--	--
	LRPAV3			130	32	113			12.5	0.093							
4	RPAV4	330		153	34	120	60	250	13	0.093	315	20	0.232	--	--	--	--
	LRPAV4			158	36	122			13.4	0.093							
5	RPAV5	440		170	38	134	70	315	20.6	0.234	355	25.6	0.377	400	31.9	0.602	--
	LRPAV5			176	40	136			21.1	0.241							
6	RPAV6	630		190	42	148	80	315	22	0.247	355	26.9	0.382	400	33.1	0.611	--
	LRPAV6			195	44	150			22.6	0.252							
7	RPAV7	1160		232	48	164	100	400	36.9	0.649	450	44.8	1.000	500	53.6	1.502	--
	LRPAV7			236	50	166			37.8	0.660							
8	RPAV8	2000		271	56	192	110	500	60.1	1.591	560	71.9	2.420	630	87.2	3.788	--
	LRPAV8			285	62	198			64.5	1.661							

Peso e Inerzia sono riferiti al Giunto completo con Foro Max
Weight and Inertia values refer to the complete Coupling with max bore

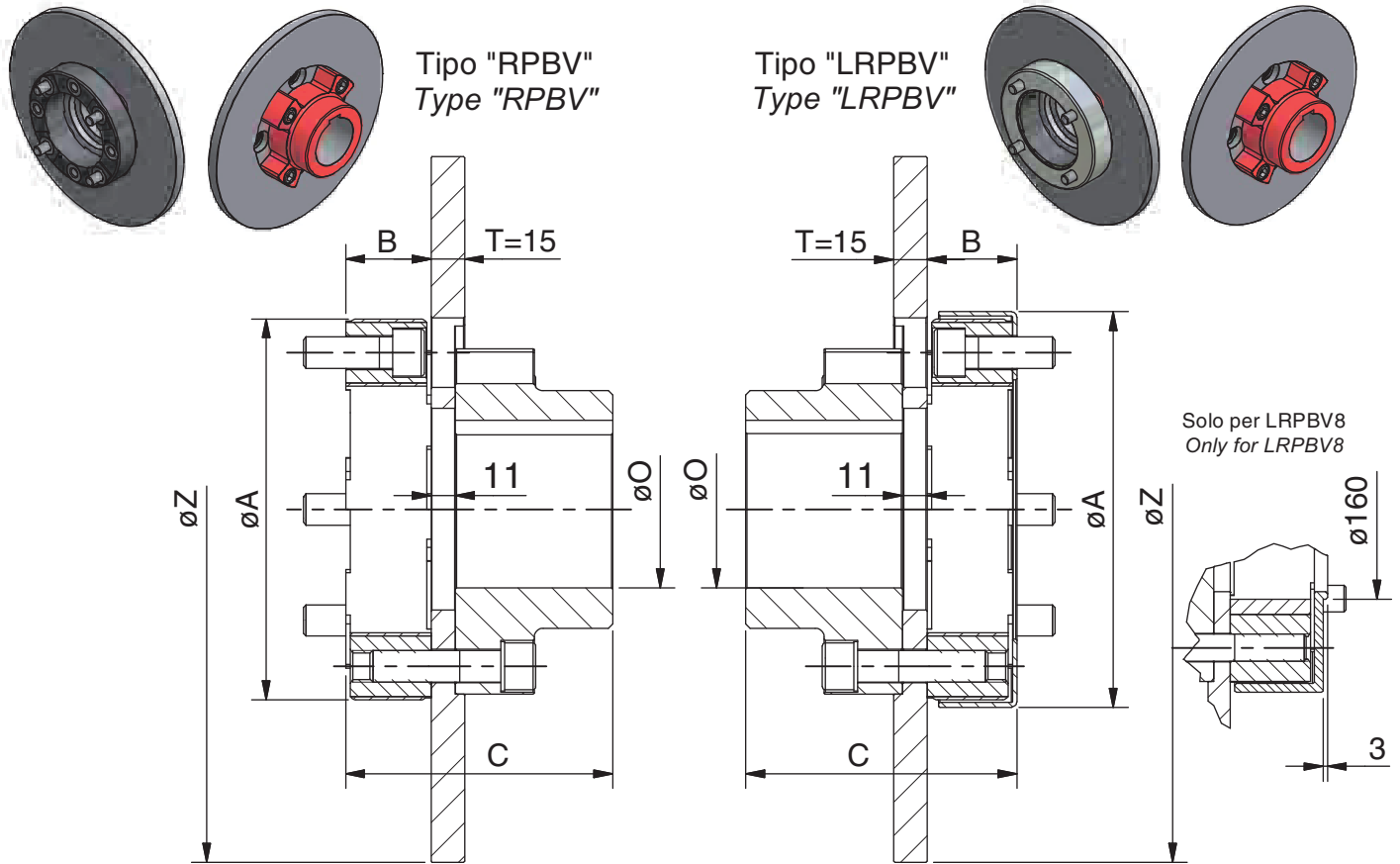

NOTA:

1. Per dimensioni Giunto elastico vedi Rotoflexi tipo "RV / LRV" a Pag. 18
For dimensions flexible Coupling see Rotoflexi type "RV / LRV" Pag. 18
2. A richiesta foro øO lavorato
Upon request bore øO machined
3. Per dimensioni foro e cava vedere tabella Pag. 22
For bore and keyway dimensions see sheet Pag. 22

FORMULA:

$$n^{\circ} \text{Max r.p.m.} = \frac{V \times 60 \times 1000}{\pi \times \varnothing Z} \text{ dove / where } V = 33 \text{ m/sec}$$

Dimensioni mm Dimensions mm

Grand Size	Tipo Type	Coppia Torque Nm	n°Max giri/1' r.p.m.	øA	B	C	øO Max	øZ	Peso Weight Kg.	Inerzia Inertia Kgm2	øZ	Peso Weight Kg.	Inerzia Inertia Kgm2	øZ	Peso Weight Kg.	Inerzia Inertia Kgm2
1	--	--	--	--	--	--	--	--	--	--	--	--	--	--	--	--
	--			--	--	--	--	--	--	--	--	--	--	--	--	--
2	RPBV2	65	--	100	22	78	38	200	4.2	0.019	--	--	--	--	--	--
	LRPBV2			104	24	80			4.4	0.019		--	--		--	--
3	RPBV3	175	--	126	30	96	48	250	7	0.047	315	10.4	0.116	--	--	--
	LRPBV3			130	32	98			7.3	0.049		10.7	0.117		--	--
4	RPBV4	330	--	153	34	105	60	250	8.1	0.052	315	11.5	0.120	--	--	--
	LRPBV4			158	36	107			8.5	0.054		11.9	0.122		--	--
5	RPBV5	440	--	170	38	119	70	315	12.7	0.126	355	15.1	0.196	400	18.3	0.308
	LRPBV5			176	40	121			13.1	0.130		15.6	0.199		18.8	0.312
6	RPBV6	630	--	190	42	133	80	315	14.3	0.137	355	16.8	0.207	400	20	0.319
	LRPBV6			195	44	135			15	0.142		17.4	0.212		20.6	0.324
7	RPBV7	1160	--	232	48	149	100	400	24.1	0.361	450	28	0.539	500	32.4	0.788
	LRPBV7			236	50	151			25	0.371		28.9	0.550		33.3	0.798
8	RPBV8	2000	--	271	56	177	110	500	39.7	0.883	560	45.6	1.297	630	53.3	1.981
	LRPBV8			285	62	183			44	0.953		50	1.367		57.6	2.051

Peso e Inerzia sono riferiti al Giunto completo con Foro Max
Weight and Inertia values refer to the complete Coupling with max bore

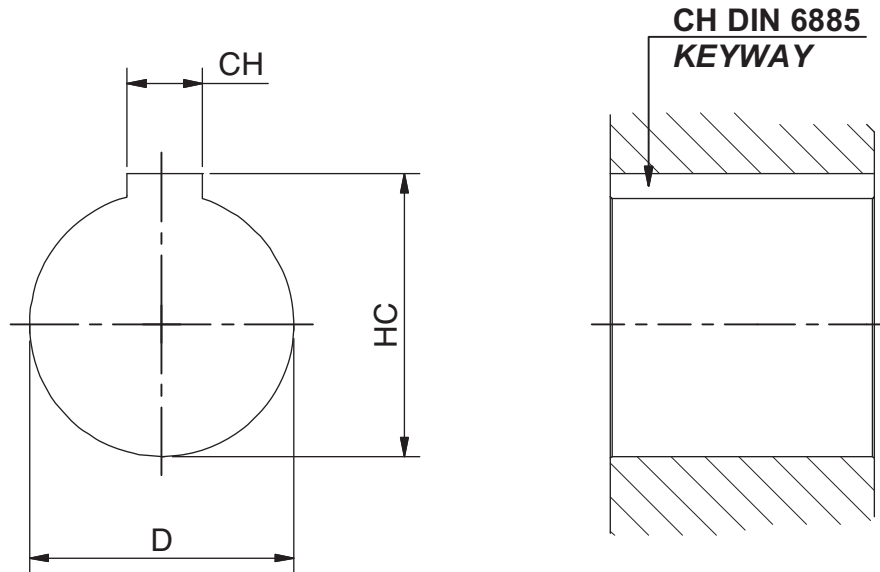

D	Toll	CH	Toll	HC	Toll
10		3		11.4	
11*		4		12.8	
12		4		13.8	
13		5		15.3	
14*		5		16.3	+0.1
15		5		17.3	0
16		5		18.3	
17		5		19.3	
18		6		20.8	
19*		6		21.8	
20		6		22.8	
21		6		23.8	
22	H7	6	Js9	24.8	
23		8		26.3	
24*		8		27.3	
25		8		28.3	
26		8		29.3	
27		8		30.3	
28*		8		31.3	+0.2
30		8		33.3	0
32		10		35.3	
33		10		36.3	
34		10		37.3	
35		10		38.3	
38*		10		41.3	
40		12		43.3	

D	Toll	CH	Toll	HC	Toll
42*		12		45.3	
45		14		48.8	
48*		14		51.8	
50		14		53.8	
55		16		59.3	
60*		18		64.4	
65*		18		69.4	
70*		20		74.9	
75*		20		79.9	
80*		22		85.4	
85*		22		90.4	
90*		25		95.4	
95	H7	25	Js9	100.4	+0.2
100*		28		106.4	0
105		28		111.4	
110*		28		116.4	
115		32		122.4	
120		32		127.4	
125*		32		132.4	
130		32		137.4	
135*		36		143.4	
140		36		148.4	
160		40		169.4	
180		45		190.4	
200		45		210.4	
250		56		262.4	

MONTAGGIO A PARETE
FLANGE MOUNTING

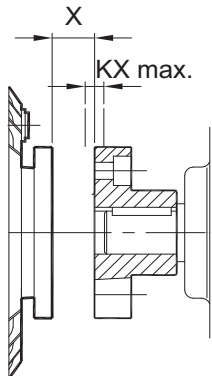

Errore Assiale
Axial error

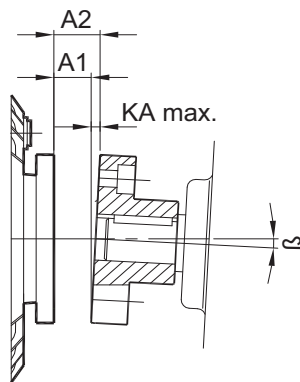

Errore Angolare
Angular error

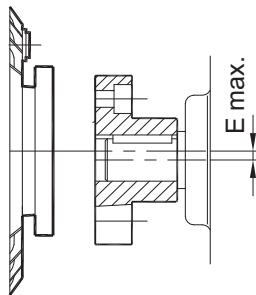

Errore Radiale
Radial error

MONTAGGIO TRA DUE ALBERI
MOUNTING AMONGST TWO SHAFT

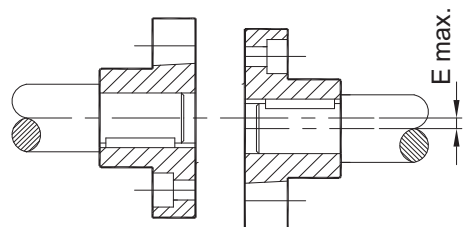
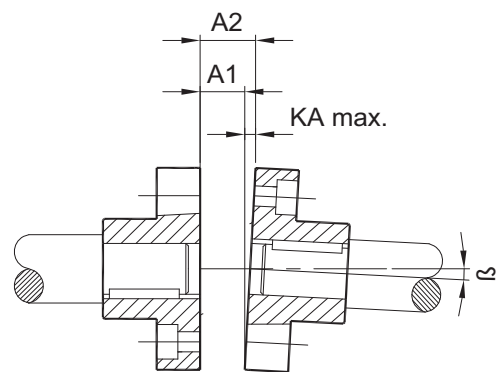
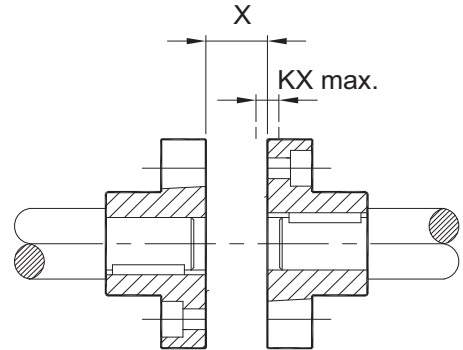

Grand. Size	Tipo Type	Assiale Axial		Angolare Angular		Radiale Radial
		X	KX Max.	β	KA Max A2-A1	E Max.
1	G	18	$\pm 0,5$	1°	0,3	0,3
	LG	20	$\pm 0,5$			
2	G	22	$\pm 0,5$	1°	0,4	0,4
	LG	24	$\pm 0,5$			
3	G	30	$\pm 0,5$	1°15'	0,4	0,4
	LG	32	$\pm 0,5$			
4	G	34	$\pm 0,5$	1°15'	0,4	0,4
	LG	36	$\pm 0,5$			
5	G	38	$\pm 0,8$	1°15'	0,4	0,4
	LG	40	$\pm 0,8$			
6	G	42	$\pm 0,8$	1°30'	0,6	0,6
	LG	44	$\pm 0,8$			
7	G	48	± 1	1°30'	0,6	0,6
	LG	50	± 1			
8	G	56	± 1	1°30'	0,6	0,6
	LG	62	± 1			

Grand. Size	Tipo Type	Assiale Axial		Angolare Angular		Radiale Radial
		X	KX Max.	β	KA Max A2-A1	E Max.
1	R	18	$\pm 0,5$	1°	0,3	0,3
	LR	20	$\pm 0,5$			
2	R	22	$\pm 0,5$	1°	0,4	0,4
	LR	24	$\pm 0,5$			
3	R	30	$\pm 0,5$	1°15'	0,4	0,4
	LR	32	$\pm 0,5$			
4	R	34	$\pm 0,5$	1°15'	0,4	0,4
	LR	36	$\pm 0,5$			
5	R	38	$\pm 0,8$	1°15'	0,4	0,4
	LR	40	$\pm 0,8$			
6	R	42	$\pm 0,8$	1°30'	0,6	0,6
	LR	44	$\pm 0,8$			
7	R	48	± 1	1°30'	0,6	0,6
	LR	50	± 1			
8	R	56	± 1	1°30'	0,6	0,6
	LR	62	± 1			

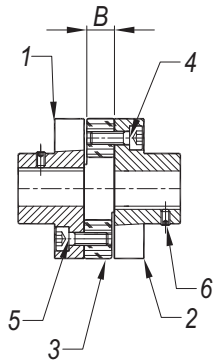

Fig. 1

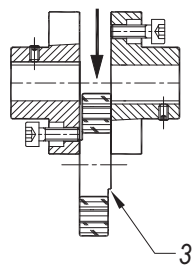

Fig. 2

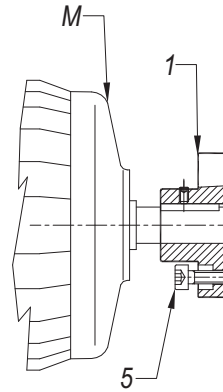

Fig. 3

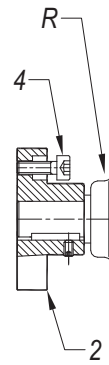

Fig. 4

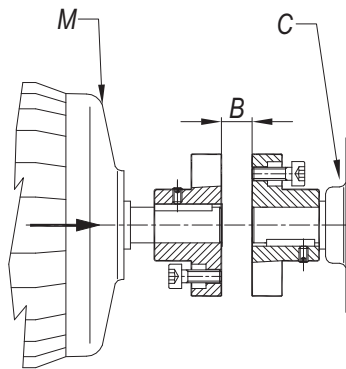

Fig. 5

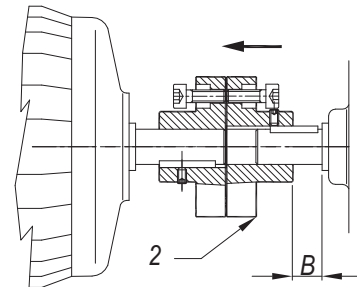

Fig. 6

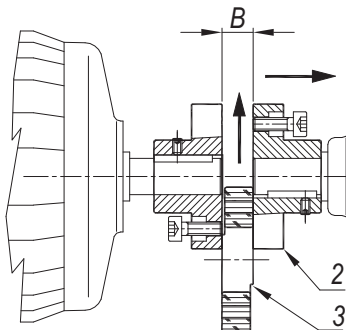

Fig. 7

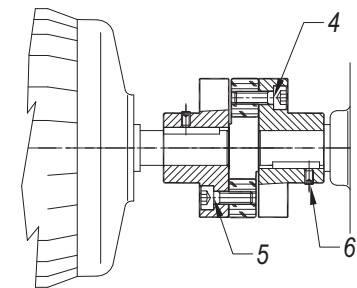
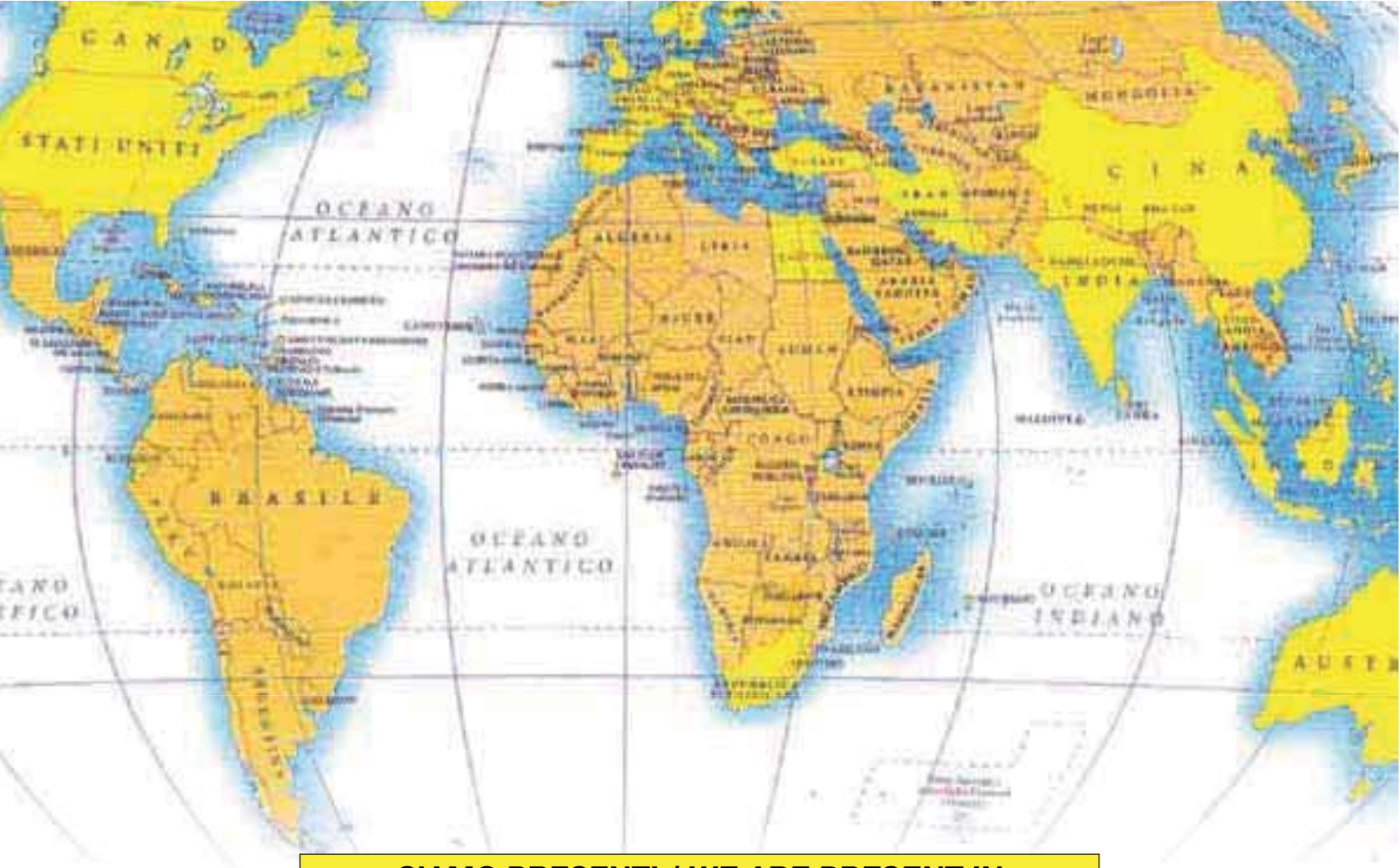

Fig. 8

Viti e coppie di serraggio/Screw and torque

Grandezza Size	Tipo Type	Viti classe 8.8 Screws clas. 8.8	Coppia Nm. Torque Nm.	Grandezza Size	Tipo Type	Viti classe 8.8 Screws clas. 8.8	Coppia Nm. Torque Nm.
1	LG/G	N° 3 M6	10	1	LR/R	N° 3+3 M8	25
		N° 3 M8	25				
2	LG/G	N° 3+3 M8	25	2	LR/R	N° 3+3 M8	25
3	LG/G	N° 4+4 M10	50	3	LR/R	N° 4+4 M10	50
4	LG/G	N° 4+4 M12	87	4	LR/R	N° 4+4 M12	87
5	LG/G	N° 4+4 M14	138	5	LR/R	N° 4+4 M14	138
6	LG/G	N° 4+4 M14	138	6	LR/R	N° 4+4 M14	138
7	LG/G	N° 4+4 M16	212	7	LR/R	N° 4+4 M16	212
8	LG/G	N° 4+4 M18	291	8	LR/R	N° 4+4 M18	291



SIAMO PRESENTI / WE ARE PRESENT IN

- | | | |
|---|---|---|
| <input type="checkbox"/> Australia / <i>Australia</i> | <input type="checkbox"/> Gran Bretagna / <i>Great Britain</i> | <input type="checkbox"/> Singapore / <i>Singapore</i> |
| <input type="checkbox"/> Austria / <i>Austria</i> | <input type="checkbox"/> India / <i>India</i> | <input type="checkbox"/> Slovenia / <i>Slovenja</i> |
| <input type="checkbox"/> Belgio / <i>Belgium</i> | <input type="checkbox"/> Indonesia / <i>Indonesia</i> | <input type="checkbox"/> Spagna / <i>Spain</i> |
| <input type="checkbox"/> Canada / <i>Canada</i> | <input type="checkbox"/> Iran / <i>Iran</i> | <input type="checkbox"/> U.S.A. / <i>U.S.A.</i> |
| <input type="checkbox"/> Cina / <i>China</i> | <input type="checkbox"/> Israele / <i>Israel</i> | <input type="checkbox"/> Sud Africa / <i>South Africa</i> |
| <input type="checkbox"/> Cipro / <i>Cyprus</i> | <input type="checkbox"/> Malesia / <i>Malaysia</i> | <input type="checkbox"/> Svezia / <i>Sweden</i> |
| <input type="checkbox"/> Corea / <i>Korea</i> | <input type="checkbox"/> Norvegia / <i>Norway</i> | <input type="checkbox"/> Svizzera / <i>Switzerland</i> |
| <input type="checkbox"/> Danimarca / <i>Denmark</i> | <input type="checkbox"/> Nuova Zelanda / <i>New Zealand</i> | <input type="checkbox"/> Tailandia / <i>Thailand</i> |
| <input type="checkbox"/> Egitto / <i>Egypt</i> | <input type="checkbox"/> Olanda / <i>Holland</i> | <input type="checkbox"/> Taiwan / <i>Taiwan</i> |
| <input type="checkbox"/> Finlandia / <i>Finland</i> | <input type="checkbox"/> Portogallo / <i>Portugal</i> | <input type="checkbox"/> Turchia / <i>Turkey</i> |
| <input type="checkbox"/> Francia / <i>France</i> | <input type="checkbox"/> Rep. Ceca / <i>Ceka Republik</i> | <input type="checkbox"/> Ungheria / <i>Hungary</i> |
| <input type="checkbox"/> Germania / <i>Germany</i> | <input type="checkbox"/> Romania / <i>Romania</i> | |

 <p>WESTCAR s.r.l. ROTOFLEXI</p>	<p>Distributore / <i>Distributor</i></p>
<p>WESTCAR s.r.l. Via Monte Rosa, 14 - 20149 MILANO (Italy) Tel. 02.76.11.03.19 r.a. - Fax 02.76.11.00.41 E-mail: info@westcar.it - www.westcar.it</p>	