

# **Bonfiglioli** Riduttori

---

## **V series**

Lista parti di ricambio

---

Spare parts list

---

Ersatzteilliste

---

Liste des pieces detachees







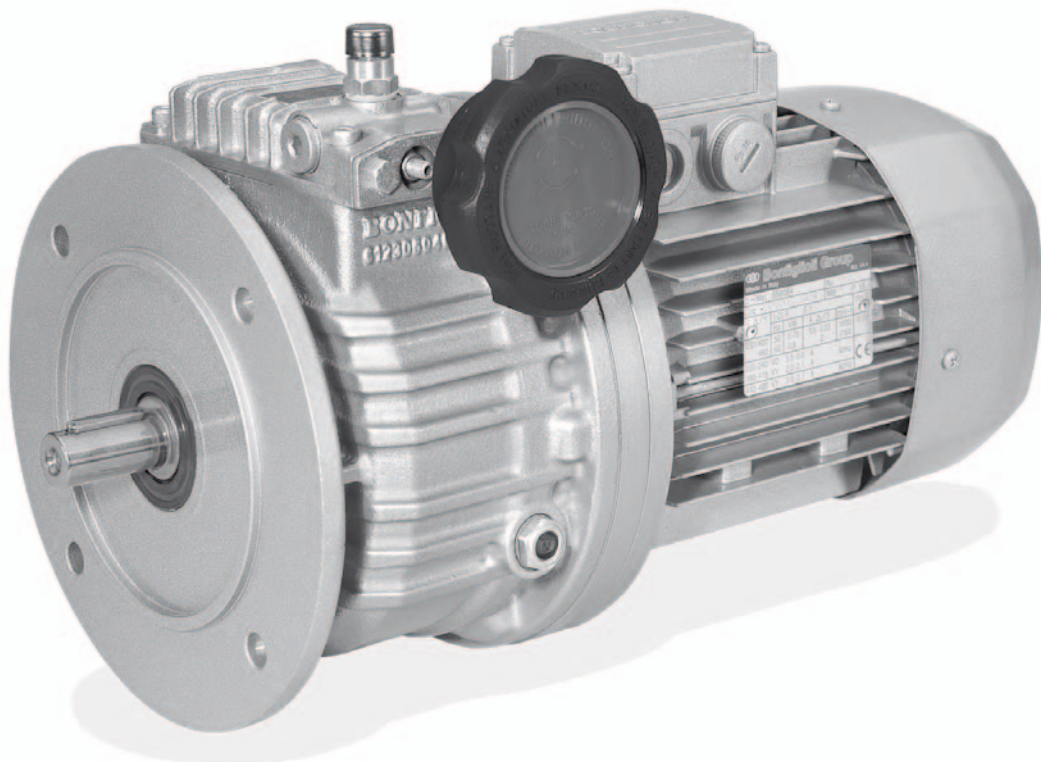



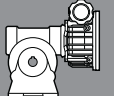
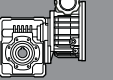
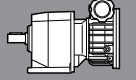
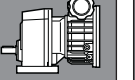



























---

















Lista de partes de recambio

---





	F	UF UP UPF	U	 Differential	 VF + V	 W + V	  C + V S + V	Kit aggiuntivi Add-on input parts Zusätzliche kit Kits d'entrée Kit adjuntos
V 0.25								
V 0.5	 +  + 	 +  + 	—	 +  + 	 +  + 	 +  + 	 +  + 	
V 1								
V 2					—	—	—	
V 3								
V 5.5	 +  + 	 +  + 	 +  + 	 +  + 	 +  + 	—	 +  + 	
V 10					—			

	U UF	P	 Differential
VR 0.25			
VR 0.5	 +  + 	 +  + 	 +  + 
VR 1			
VR 2			
VR 3			
VR 5.5	 +  + 	—	 +  + 
VR 10			

**Quadro d'unione delle tavole parti di ricambio**  
**Index of spare parts tables**  
**Inhaltsverzeichnis Ersatzteillisten**  
**Index des tables de pièces de rechange**  
**Índice de la tabla de partes de recambio**

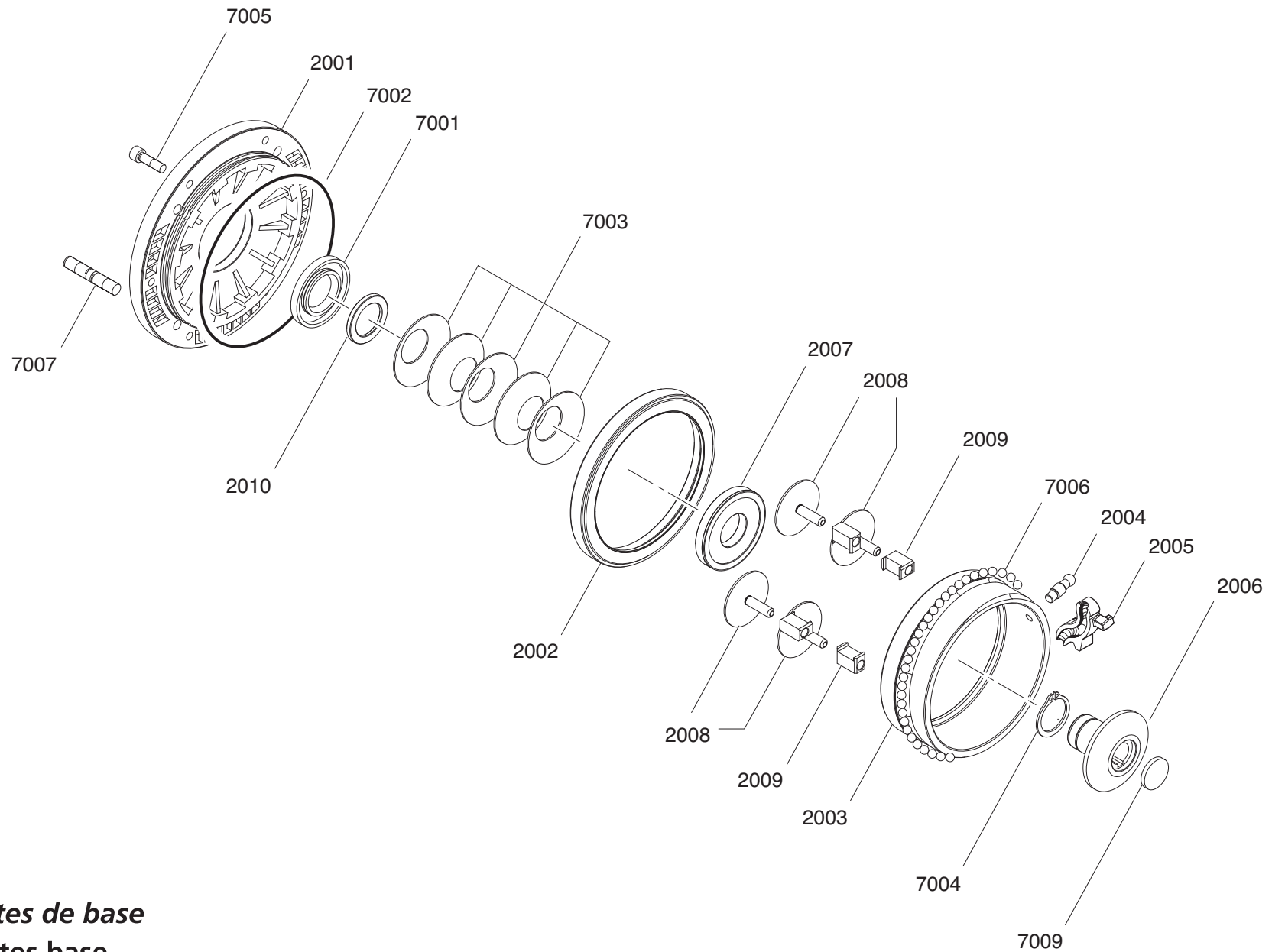

Parti base

Core parts





Kern teile

Composantes de base

Componentes base



Pos.	Descrizione	Description	Benennung	Description	Descripción
2001	Coperchio entrata	Input flange	Eingangsfansch	Bride d'entrée	Brida de entrada
2002	Anello esterno fisso	Fixed ring	Ring feststehend	Anneau externe fixe	Anillo exterior fijo
2003	Anello esterno mobile	Mobile outer ring	Außenring beweglich	Anneau externe mobile	Anillo exterior movil
2004	Perno di comando	Pin	Stift	Axe de commande	Perno de mando
2005	Ricircolo	Recirculating element	Rückführung	Élément de recirculation	Elemento de recirculacion
2006	Disco motore	Tapered sun disc	Antriebsscheibe	Disque solaire	Disco motor
2007	Anello spinta satellite	Planet disc thrust ring	Druckring	Anneau pousse-satellite	Anillo empuja satelite
2008	Satellite	Planet disc	Planetenrad	Satellite	Satelite
2009	Boccola satellite	Planet disc bushing	Nutenstein	Douille de satellite	Casquillo para satelite
2010	Anello arresto molle	Washers stop ring	Anschlagscheibe	Anneau d'arrêt	Anillo tope muelles
7003	Molle a tazza	Belleville washers	Tellerfeder	Rondelle Belleville	Arandelas muelle
7006	Sfere	Balls	Kugeln	Billes	Bolas
7007	Prigioniero	Stud bolt	Gewindestift	Goujons	Prisionero
7009	Cappello	Rubber plug	Gummideckel	Bouchon	Tapon de goma

		 OR		
	7001	7002	7004	7005
V 0.25	25x40x7	3375	25	M5x12
V 0.5	28x52x7	3475	28	M5x12
V 1	P80 30x62x7	ORM 1480-40	30	M6x20
	P90 35x62x7			
V 2	45x72x8	4700	45	M8x18

V 3





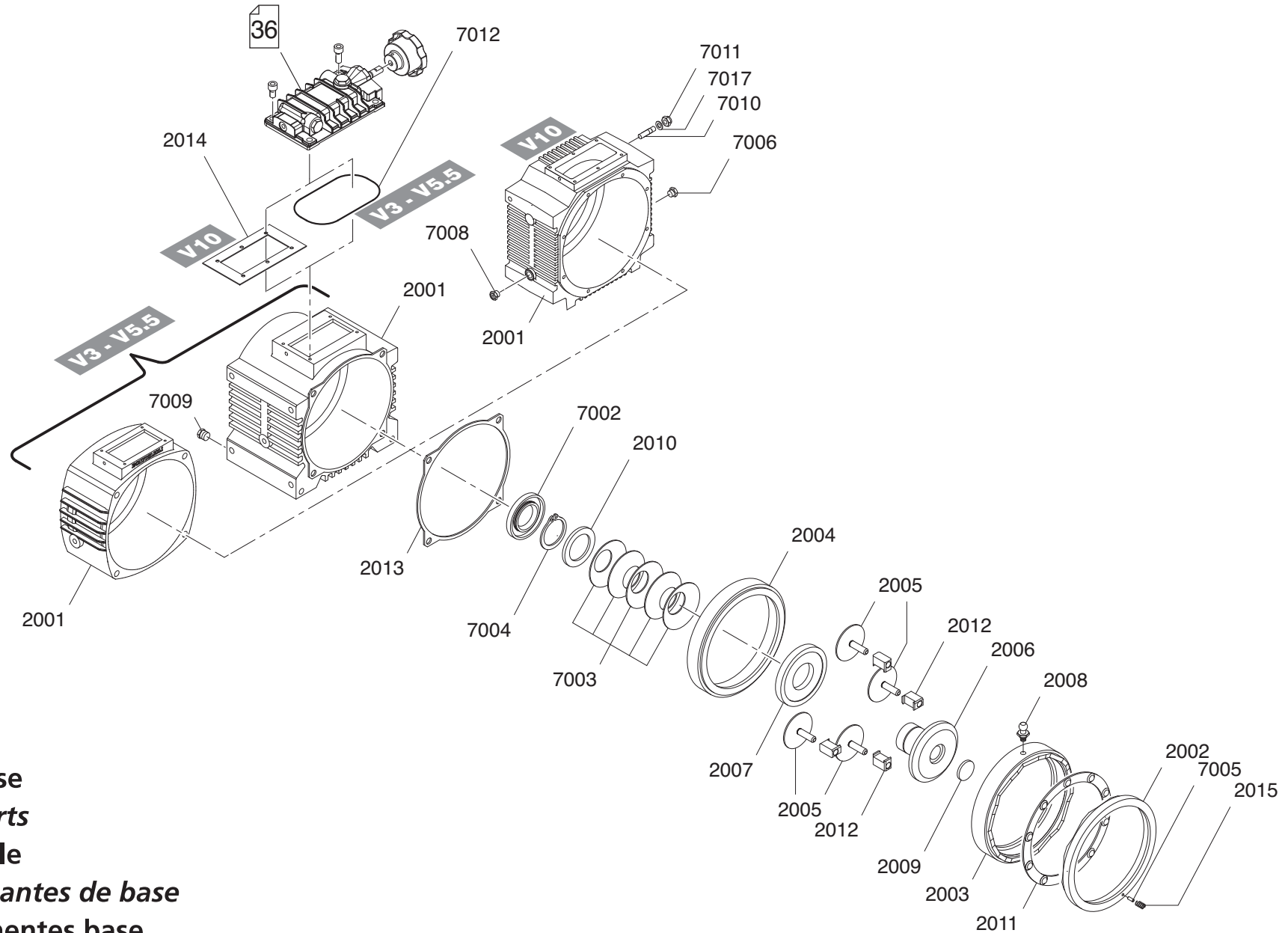



V 5.5

V 10



Parti base  
Core parts  
Kern teile  
Composantes de base  
Componentes base





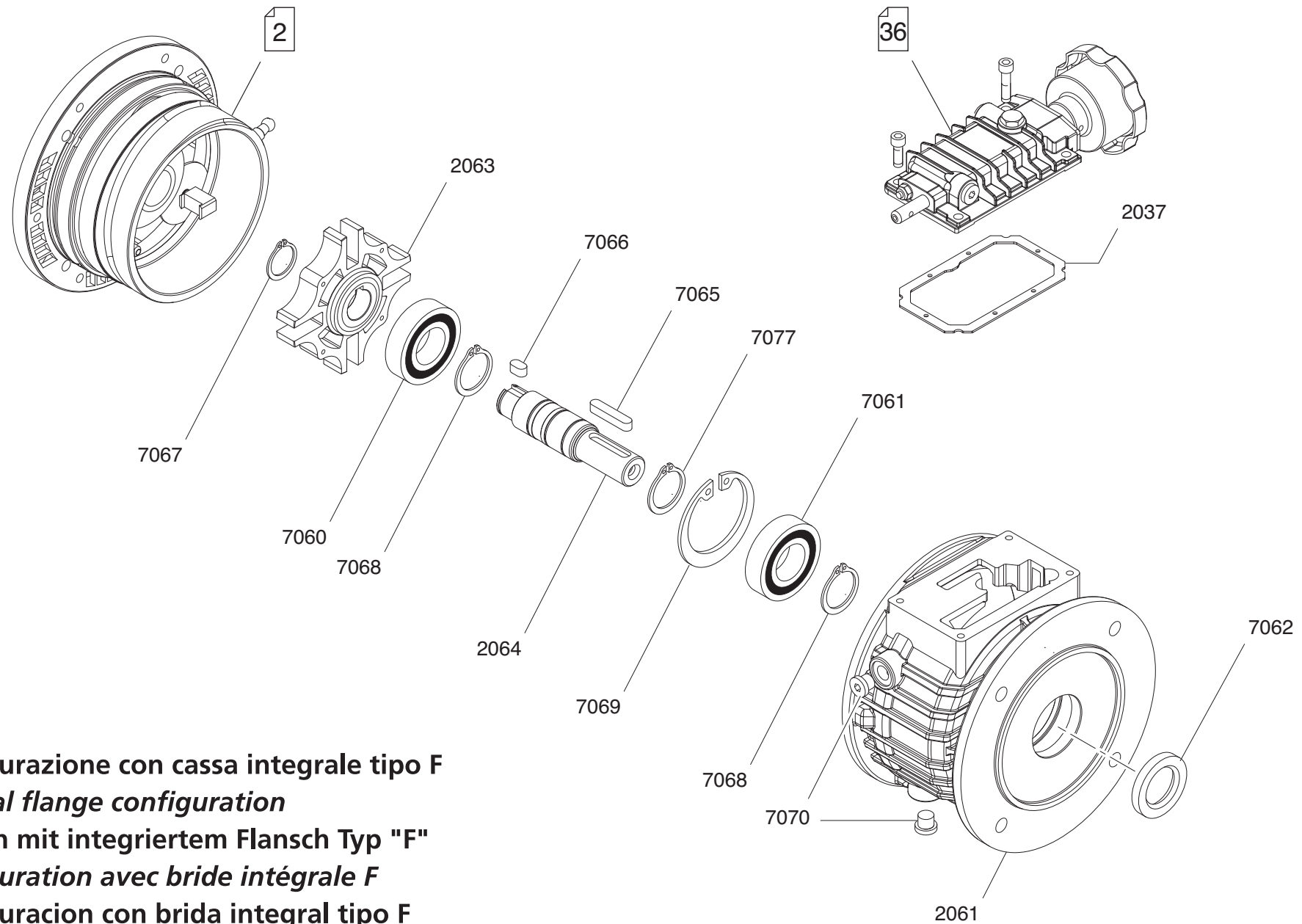

Pos.	Descrizione	Description	Benennung	Description	Descripción
2001	Cassa	Housing	Gehäuse	Carter	Caja
2002	Anello esterno fisso	Fixed cam disc	Kurvenscheibe feststehend	Anneau externe fixe	Disco leva fijo
2003	Anello esterno mobile	Mobile outer ring	Außenring beweglich	Anneau externe mobile	Anillo exterior móvil
2004	Anello esterno fisso	Fixed outer ring	Außenring feststehend	Anneau externe fixe	Anillo exterior fijo
2005	Satellite	Planet disc	Planetenrad	Satellite	Satelite
2006	Disco motore	Tapered sun disc	Antriebsscheibe	Disque solaire	Disco motor
2007	Anello spinta satellite	Planet disc thrust ring	Druckring Planetenrad	Anneau pousse-satellite	Anillo empuja satelite
2008	Perno di comando	Pin	Stift	Axe de commande	Perno de mando
2009	Tappo disco motore	Plug	Verschluss	Bouchon	Tapon disco motor
2010	Anello arresto molle	Washers stop ring	Anschlagscheibe	Anneau d'arrêt	Anillo tope muelles
2011	Gabbia con sfere	Thrust bearing	Kugelkäfig	Cage à billes	Jaula con bolas
2012	Boccola per satellite	Planet disc bushing	Nutenstein Planetenrad	Douille de satellite	Casquillo para satelite
2013	Guarnizione uscita	Gasket	Dichtung Ausgang	Joint plat	Junta de salida
2014	Guarnizione	Gasket	Dichtung	Joint plat	Junta
2015	Molla cilindrica	Helical spring	Schraubenfeder	Ressort	Muelle
7003	Molla tazza	Belleville spring	Tellerfeder	Rondelle Belleville	Arandela muelle
7010	Prigioniero	Stud bolt	Gewindestift	Goujon	Prisionero

									
	7002	7004	7005	7006	7008	7009	7011 UNI 7473	7012	7017
V 3	55x72x8	55	ø5x14	3/8" GAS	3/8" GAS	1/4" GAS	M6	4462	6x10x1
V 5.5	55x72x8	55	ø5x14	3/8" GAS	3/8" GAS	1/4" GAS	M6	4462	6x10x1
V 10	60x85x10	60	ø6x20	3/8" GAS	3/8" GAS	1/4" GAS	M8	—	8x12x1



**Configurazione con cassa integrale tipo F**  
***Integral flange configuration***  
**Version mit integriertem Flansch Typ "F"**  
***Configuration avec bride intégrale F***  
**Configuración con brida integral tipo F**





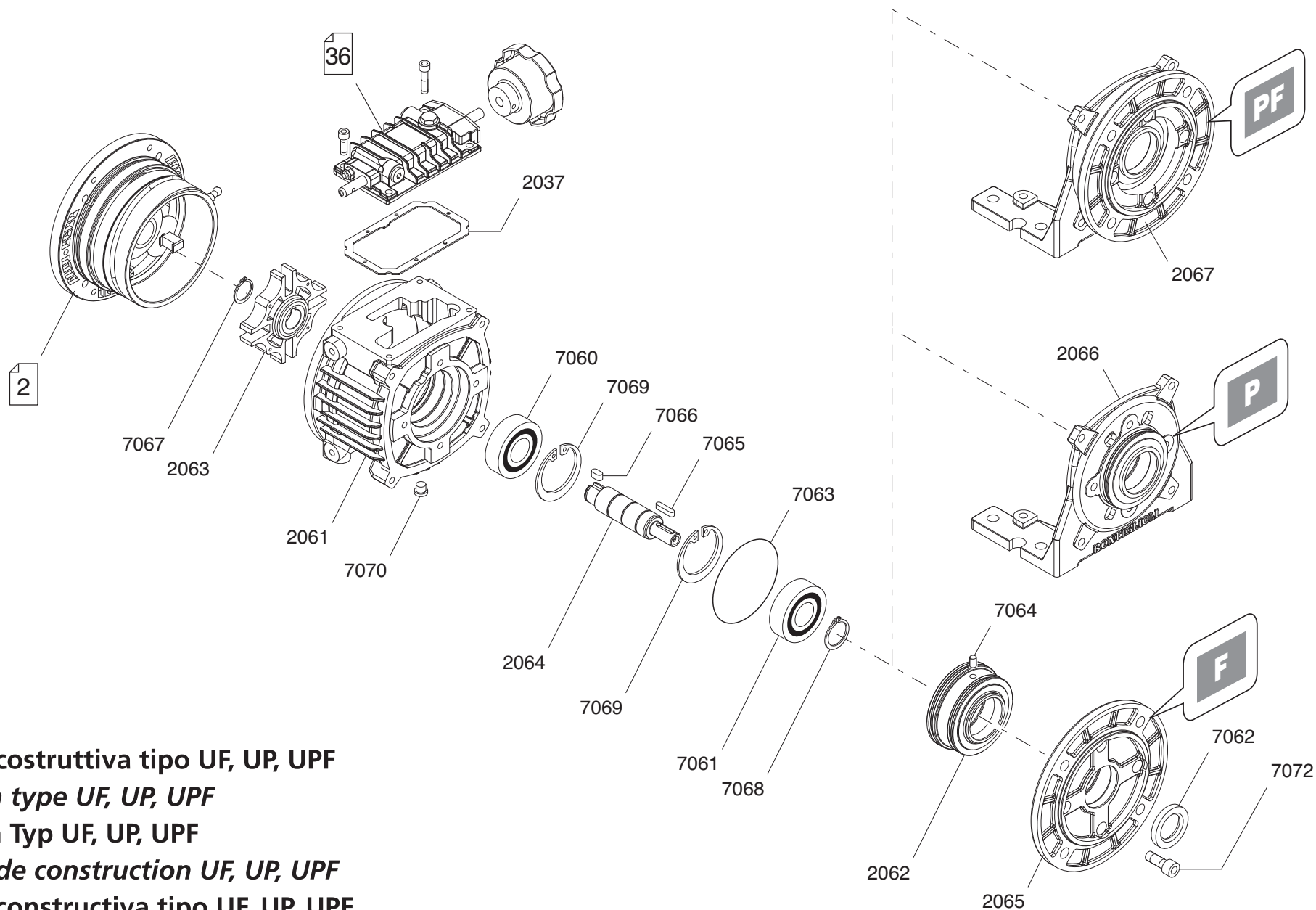



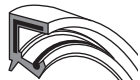

Pos.	Descrizione	Description	Benennung	Description	Descripción
2037	Guarnizione	Gasket	Dichtung	Joint plat	Junta
2061	Cassa	Housing	Gehäuse	Carter	Caja
2063	Disco portasatelliti	Planet disc carrier	Planetenträgerscheibe	Porte satellite	Disco portasatelites
2064	Albero uscita	Output shaft	Abtriebswelle	Arbre de sortie	Eje de salida

										
	7060	7061	7062	7065	7066	7067	7068	7077	7069	7070
V 0.25 F	6204	6204 2Z	20x40x7	4x4x18 (D11) 5x5x25 (D14) 4.76x4.76x35 (IMP)	5x5x10	16	20	20	47	1/8" GAS
V 0.5 F	6204	6204 2Z	20x40x7	5x5x25 (D14) 6x6x30 (D19) 4.76x4.76x35 (IMP)	5x5x10	16	20	20	47	1/8" GAS
V 1 F	6206	6206 2Z	30x50x7	6x6x30 (D19) 8x7x40 (D24) 4.76x4.76x35 (IMP)	8x7x14	24	30	30	62	1/4" GAS
V 2 F	6207	6207 2Z	35x62x7	8x7x40 (D24) 8x7x50 (D28) 4.76x4.76x35 (IMP)	8x7x18	28	35	35	72	1/4" GAS



**Forma costruttiva tipo UF, UP, UPF**  
**Version type UF, UP, UPF**  
**Version Typ UF, UP, UPF**  
**Forme de construction UF, UP, UPF**  
**Forma constructiva tipo UF, UP, UPF**

Pos.	Descrizione	Description	Benennung	Description	Descripción
2037	Guarnizione	Gasket	Dichtung	Joint plat	Junta
2061	Cassa forma costruttiva U	Housing version "U"	Gehäuse Version "U"	Carter U	Caja en forma constructiva U
2062	Supporto	Support sleeve	Halterung	Support	Soporte
2063	Disco portasatelliti	Planet disc carrier	Planetenträgerscheibe	Porte satellite	Disco portasatelites
2064	Albero uscita	Output shaft	Abtriebswelle	Arbre de sortie	Eje de salida
2065	Flangia di fissaggio	Mounting flange	Befestigungsflansch	Bride F	Brida de fijacion
2066	Piede	Foot arrangement	Fuß	Patte	Pata
2067	Flangia riportata su piede	Bolt-on flange	Fuß mit Befestigungsflansch	Bride rapportéé sur patte	Brida postiza
7072	Viti di collegamento	Connecting bolt	Verbindungsschraube	Vis	Tornillos de fijacion



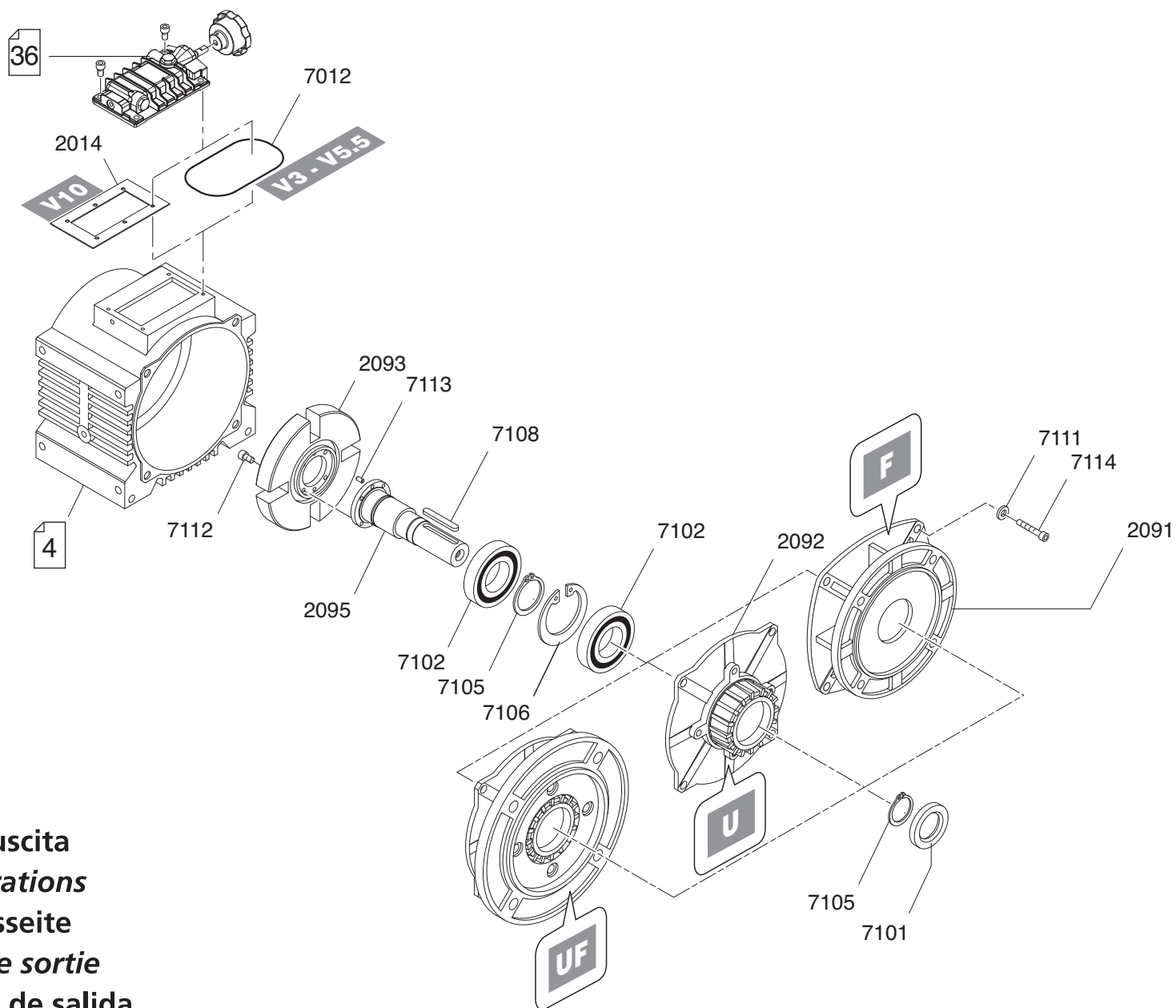



											
	7060	7061	7062	OR 7063	7064	7065	7066	7067	7068	7069	7070
<b>V 0.25 U_</b>	6204	6204 2Z	20x35x7	3225	—	4x4x18 (D11) 5x5x25 (D14) 4.76x4.76x35 (IMP)	5x5x10	16	20	47	1/8" GAS
<b>V 0.5 U_</b>	6204	6204 2Z	20x35x7	3256	ø5x8	5x5x25 (D14) 6x6x30 (D19) 4.76x4.76x35 (IMP)	5x5x10	16	20	47	1/8" GAS
<b>V 1 U_</b>	6206	6206 2Z	30x47x7	3300	ø5x8	6x6x30 (D19) 8x7x40 (D24) 4.76x4.76x35 (IMP)	8x7x14	24	30	62	1/4" GAS
<b>V 2 U_</b>	6207	6207 2Z	35x62x7	3375	ø5x8	8x7x40 (D24) 8x7x50 (D28) 4.76x4.76x35 (IMP)	8x7x18	28	35	72	1/4" GAS



**Configurazioni uscita**  
**Output configurations**  
**Aufbau Abtriebsseite**  
**Configuration de sortie**  
**Configuraciones de salida**

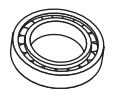

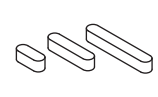

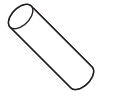
Pos.	Descrizione	Description	Benennung	Description	Descripción
2014	Guarnizione	Gasket	Dichtung	Joint plat	Junta
2091	Coperchio uscita con flangia	Mounting flange	Befestigungsflansch	Bride F	Tapa de salida con brida
2092	Coperchio uscita per flangia	Front cover	Ausgangsdeckel	Couvercle U	Tapa de salida para brida
2093	Disco portasatelliti	Planet disc carrier	Planetenträgerscheibe	Porte satellite	Disco porta satelites
2095	Albero uscita	Output shaft	Abtriebswelle	Arbre de sortie	Eje de salida
7111	Rosetta	Washer	Scheibe	Rondelle	Arandela
7114	Vite di collegamento	Connecting bolt	Verbindungsschraube	Vis	Tornillo de fijacion

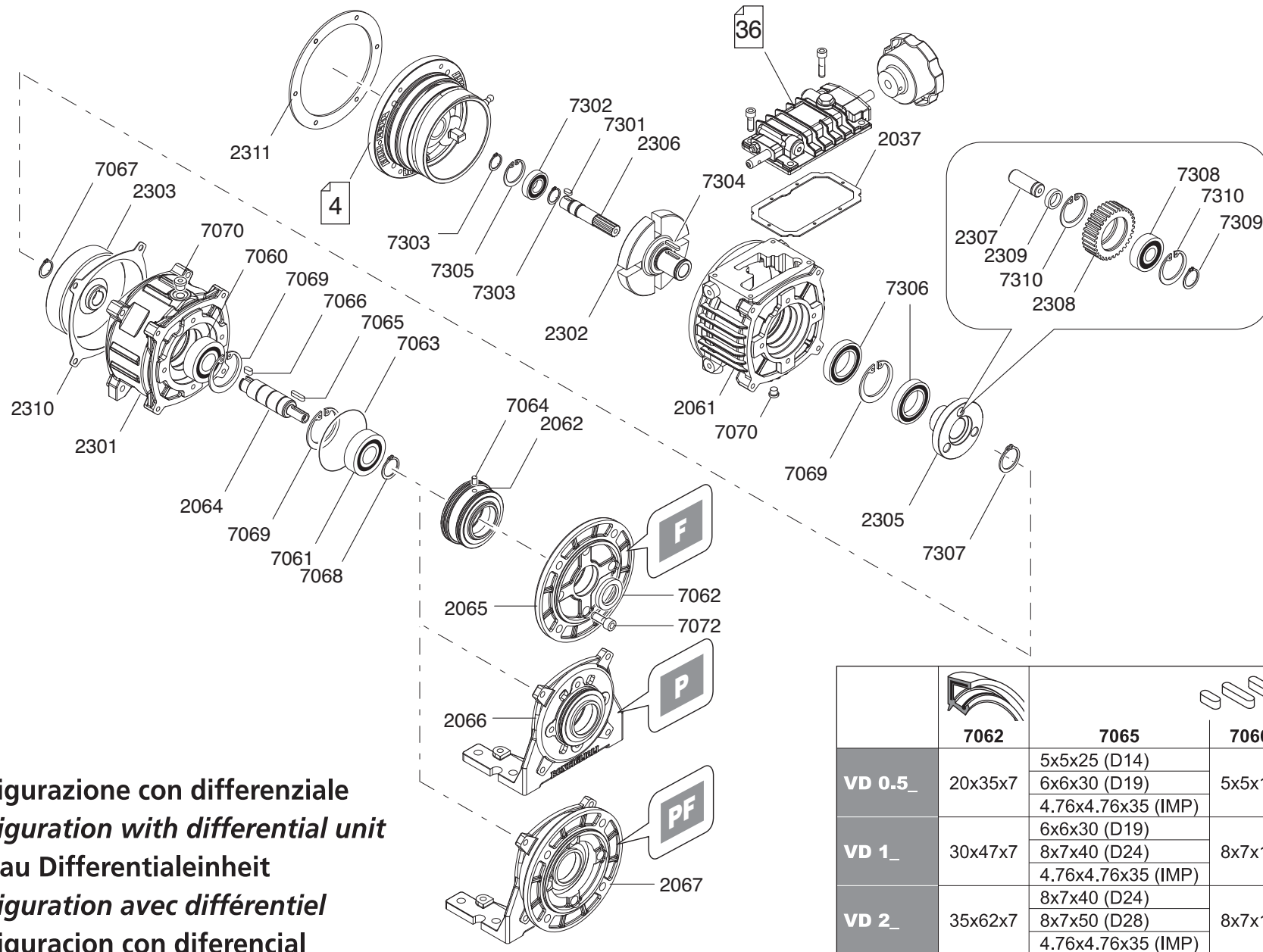



	 OR	 7101	 7102	 7105	 7106	 7108	 7112	 7113
V 3	4462	40x72x7	6308	40	90	8x7x50	M6x12	ø6x16
V 5.5	4462	40x72x7	6308	40	90	8x7x50	M6x12	ø6x16
V 10	—	45x80x10	6309	45	100	10x8x70	M8x14	ø8x16



**Configurazione con differenziale**  
**Configuration with differential unit**  
**Aufbau Differentialeinheit**  
**Configuration avec différentiel**  
**Configuración con diferencial**

					
	<b>7062</b>	<b>7065</b>	<b>7066</b>	<b>7301</b>	<b>7304</b>
<b>VD 0.5_</b>	20x35x7	5x5x25 (D14)	5x5x10	5x4.5x10	4x4x20
		6x6x30 (D19)			
		4.76x4.76x35 (IMP)			
<b>VD 1_</b>	30x47x7	6x6x30 (D19)	8x7x14	6x5.5x12	5x5x25
		8x7x40 (D24)			
		4.76x4.76x35 (IMP)			
<b>VD 2_</b>	35x62x7	8x7x40 (D24)	8x7x18	8x6.5x13	5x5x25
		8x7x50 (D28)			
		4.76x4.76x35 (IMP)			



Pos.	Descrizione	Description	Benennung	Description	Descripción
2037	Guarnizione	Gasket	Dichtung	Joint plat	Junta
2061	Cassa esecuzione U	Housing version "U"	Gehäuse Version "U"	Carter version U	Caja en ejecucion U
2062	Supporto	Support sleeve	Halterung	Support	Casquillo soporte
2064	Albero uscita	Output shaft	Abtriebswelle	Arbre de sortie	Eje de salida
2065	Flangia di fissaggio	Mounting flange	Befestigungsflansch	Bride F	Brida de fijacion
2066	Piede	Foot arrangement	Fuß	Patte	Pata
2067	Flangia riportata su piede	Bolt-on flange	Fuß mit Befestigungsflansch	Vis	Brisa postiza sobre pata
2301	Cassa differenziale	Differential gear case	Differentialgehäuse	Carter de différentiel	Caja diferencial
2302	Disco portasatelliti	Planet disc carrier	Planetenträgerscheibe	Porte satellite	Disco portasatelites
2303	Corona differenziale	Differential ring gear	Ringrad	Couronne différentiel	Corona diferencial
2305	Albero porta ingranaggio	Planet gear carrier	Planetenradträger	Porte planétaire	Eje porta engranajes
2306	Albero con pignone	Pinionshaft	Ritzelwelle	Pignon arbré	Eje piñon
2307	Perno ingranaggio differenziale	Planet gear roller	Zapfen für Zahnrad	Axe de planèteare	Perno engranaje diferencial
2308	Ingranaggio differenziale	Differential planet gear	Planetenrad Differential	Engrenage planétaire	Engranaje diferencial
2309	Distanziale	Spacer ring	Distanzring	Entretoise	Distanciador
2310	Guarnizione cassa differenziale	Gasket	Gehäusedichtung	Joint plat	Junta caja diferencial
2311	Guarnizione	Gasket	Dichtung	Joint plat	Junta
7072	Vite di collegamento	Connecting bolt	Verbindungsschraube	Vis	Tornillo de fijacion

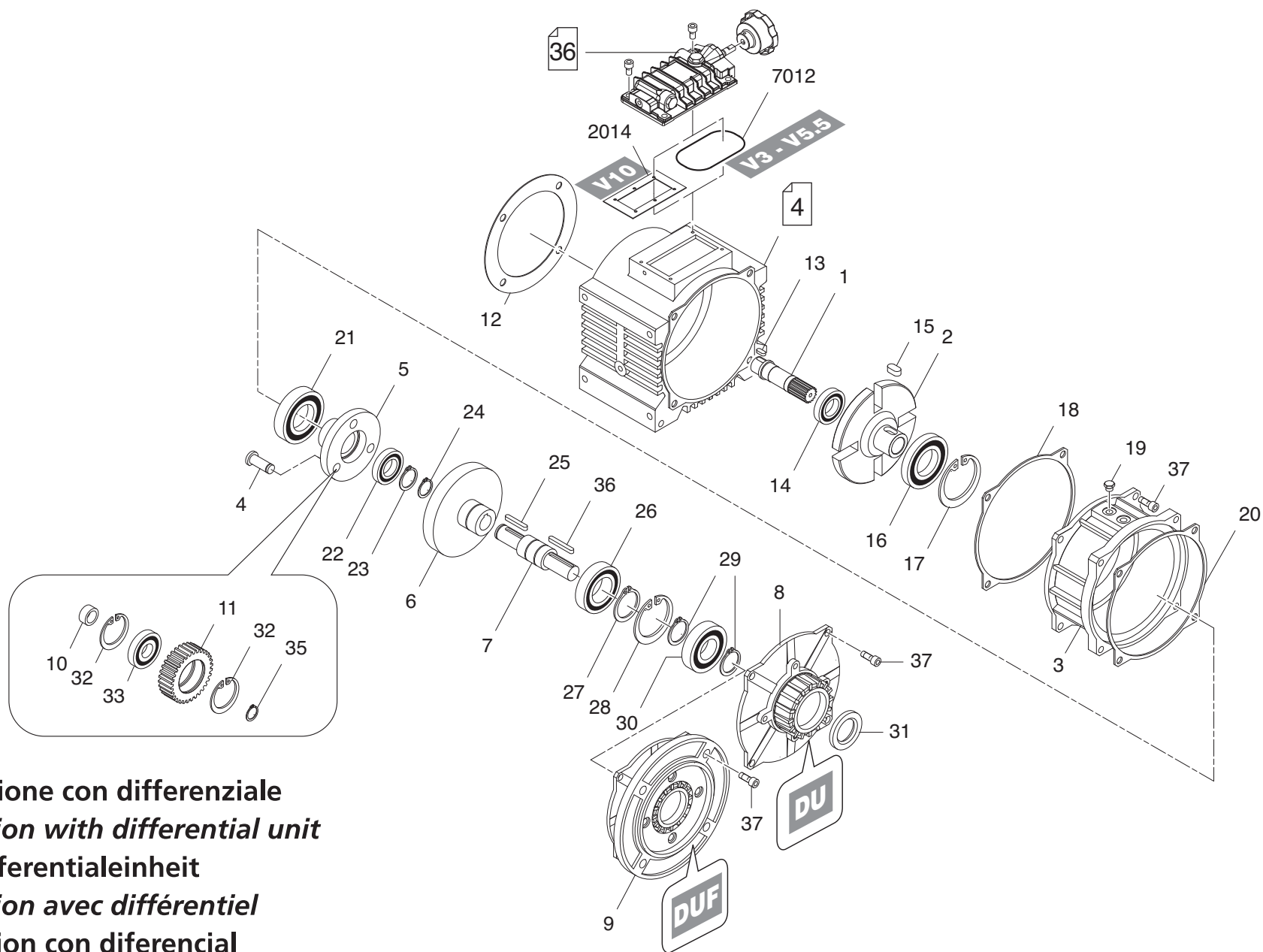

						OR 								
	7060	7061	7302	7306	7308		7063	7067	7068	7303	7307	7309	7069	7305
VD 0.5_	6204	6204 2Z	16002	61906	6000	3256	16	20	15	24	10	47	32	26
VD 1_	6206	6206 2Z	16004	61908	6000	3300	24	30	20	29	10	62	42	26
VD 2_	6207	6207 2Z	16005	61910	6202	3375	28	35	25	35	15	72	47	35



**Configurazione con differenziale**  
**Configuration with differential unit**  
**Aufbau Differentialeinheit**  
**Configuration avec différentiel**  
**Configuración con diferencial**

Pos.	Descrizione	Description	Benennung	Description	Descripción
1	Albero	Shaft	Welle	Pignon arbré	Eje
2	Disco portasatellite	Planet disc carrier	Planetenträgerscheibe	Porte satellite	Disco portasatelite
3	Cassa differenziale	Differential gear case	Differentialgehäuse	Carter de différentiel	Caja diferencial
4	Perno ingranaggio differenziale	Roller	Zapfen für Zahnrad	Axe de planèteare	Perno engranaje diferencial
5	Albero porta ingranaggio	Planet gear carrier	Planetenradträger	Porte planétaire	Eje porta engranejes
6	Corona differenziale	Differential ring gear	Ringrad Differential	Couronne différentiel	Corona diferencial
7	Albero uscita	Output shaft	Abtriebswelle	Arbre de sortie	Eje de salida
8	Coperchio esecuzione U	Front cover U version	Deckel Version "U"	Couvercle U	Tapa ejecucion U
9	Coperchio esecuzione UF	Flanged cover UF version	Deckel mit Flansch Version "UF"	Couvercle UF	Tapa ejecucion UF
10	Distanziale	Spacer ring	Distanzring	Entretoise	Distanciador
11	Ingranaggio differenziale	Differential planet gear	Planetenrad Differential	Engrenage planétaire	Engranaje diferencial
12	Guarnizione cassa	Gasket	Gehäusedichtung	Joint plat	Junta caja
18	Guarnizione cassa	Gasket	Gehäusedichtung	Joint plat	Junta caja
19	Tappo	Plug	Verschuß	Bouchon	Tapon
20	Guarnizione coperchio frontale	Gasket	Deckeldichtung	Joint plat	Junta tapa frontal
36	vite di collegamento	Connecting bolt	Verbindungsschraube	Vis	Tornillo de fijacion
37	vite di collegamento	Connecting bolt	Verbindungsschraube	Vis	Tornillo de fijacion
2014	Guarnizione	Gasket	Dichtung	Joint plat	Junta



									
	14	16	21	22	26	30	33	31	OR 7012
VD 3	6006	16011	6011	6206	6210	6308 2Z	6303	40x72x7	4462
VD 5.5	6006	16011	6011	6206	6210	6308 2Z	6303	40x72x7	4462
VD 10	6006	6011	6011	6206	6211	6309	6303	45x80x10	—

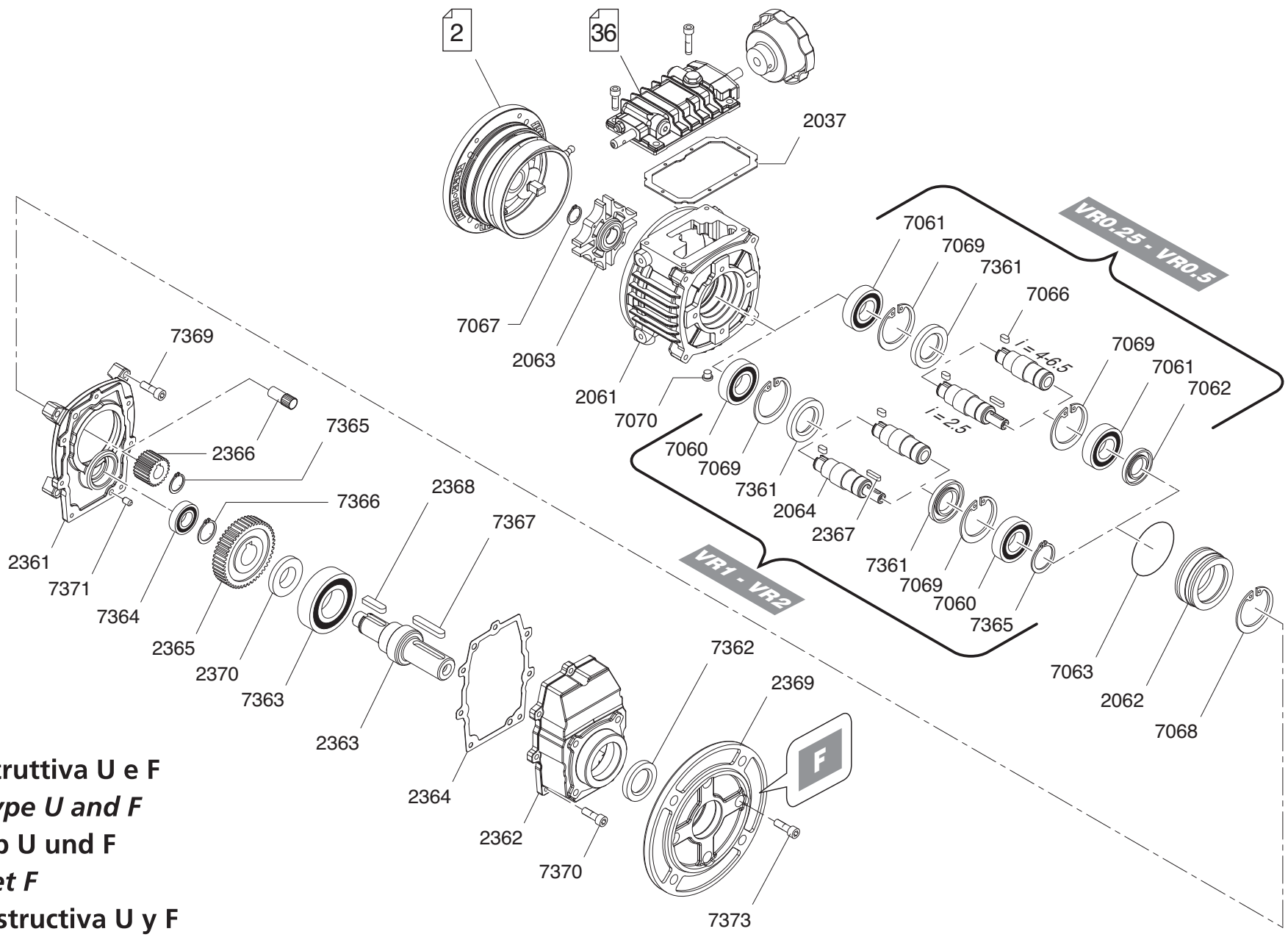

												
	13	15	25	36	17	28	32	23	24	27	29	35
VD 3	8x6.5x18	6x6x30	8x7x50	8x7x50	90	90	47	30	28	50	40	17
VD 5.5	8x6.5x18	6x6x30	8x7x50	8x7x50	90	90	47	30	28	50	40	17
VD 10	8x7.5x20	6x6x30	10x8x65	10x8x70	90	100	47	30	35	55	45	17

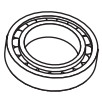

**Forma costruttiva U e F**  
**Versions type U and F**  
**Version Typ U und F**  
**Formes U et F**  
**Forma constructiva U y F**

Pos.	Descrizione	Description	Benennung	Description	Descripción
2037	Guarnizione	Gasket	Dichtung	Joint plat	Junta
2061	Cassa esecuzione U	Housing version U	Gehäuse Version "U"	Carter U	Caja ejecucion U
2062	Supporto per cuscinetto	Support sleeve	Halterung	Support de roulement	Soporte para cojinete
2063	Disco portasatelliti	Planet disc carrier	Planetenträgerscheibe	Porte satellite	Disco portasatelites
2064	Albero uscita	Output shaft	Abtriebswelle	Arbre de liaison	Eje de salida
2361	Coperchio collegamento	Connecting flange	Verbindungsflansch	Couvercle de liaison	Brida de union
2362	Cassa riduzione R	Gear case	Gehäuse Vorstufe "R"	Carter R	Caja reduccion R
2363	Albero uscita	Output shaft	Abtriebswelle	Arbre de sortie	Eje de salida
2364	Guarnizione	Gasket	Dichtung	Joint plat	Junta
2365	Corona	Gear	Zahnrad	Couronne	Corona
2366	Pignone	Pinion gear	Ritzel	Pignon	Piñon
2369	Flangia uscita	Mounting flange	Befestigungsflansch	Bride F	Brida de salida
2370	Distanziale	Spacer ring	Distanzring	Entretoise	Distanciador
7369	Vite di collegamento	Connecting bolt	Verbindungsschraube	Vis	Tornillo de fijacion
7370	Vite di collegamento	Connecting bolt	Verbindungsschraube	Vis	Tornillo de fijacion
7373	Vite di collegamento	Connecting bolt	Verbindungsschraube	Vis	Tornillo de fijacion

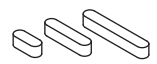
					OR					
	7060	7061	7363	7364	7063	7067	7068	7365	7366	7069
VR 0.25_	6204	6204 2RS	6005	6201	3225	16	20	11	17	47
VR 0.5_	6204	6204 2RS	6005	6201	3256	16	20	11	17	47
VR 1_	6206	—	6005	6202	3300	24	30	14	19	62
VR 2_	6207	—	6206	6204	3375	28	35	18	24	72

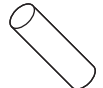
									
	2367	2368	7066	7367	7070	7062	7361	7362	7371
VR 0.25_	4x4x16	6x6x15	5x5x10	6x6x35	1/8" GAS	20x35x7	25x47x7	30x42x7	ø6x10
VR 0.5_	4x4x16	6x6x15	5x5x10	6x6x35	1/8" GAS	20x35x7	25x47x7	30x42x7	ø6x10
VR 1_	5x5x17.8	6x6x16	8x7x14	8x7x45	1/4" GAS	—	35x62x7	30x42x7	ø6x10
VR 2_	6x6x20	8x7x19	8x7x18	8x7x50	1/4" GAS	—	40x72x7	35x52x7	ø6x10



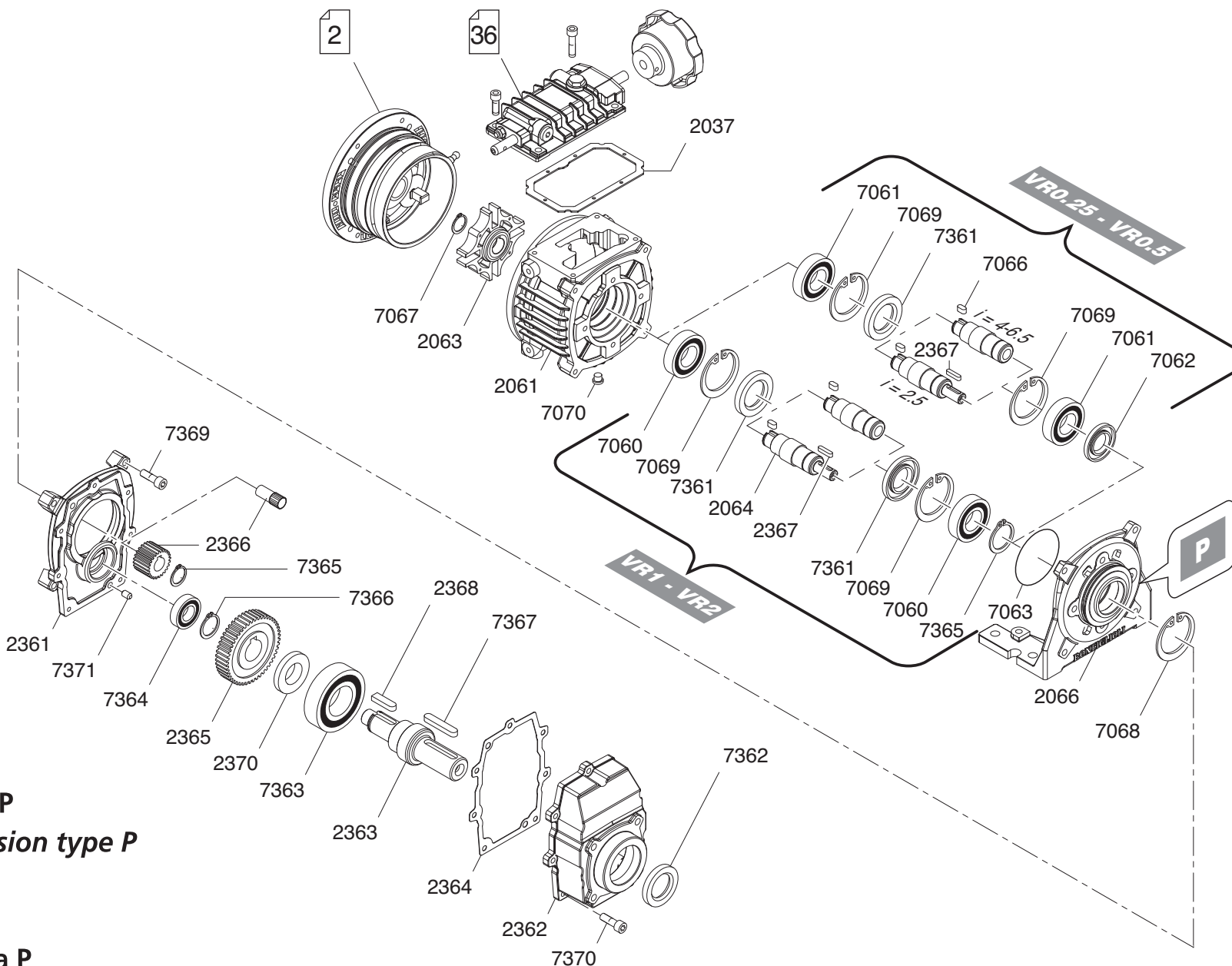







**Forma costruttiva P**  
**Foot mounted version type P**  
**Versions type P**  
**Forme à patte**  
**Forma constructiva P**





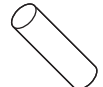

Pos.	Descrizione	Description	Benennung	Description	Descripción
2037	Guarnizione	Gasket	Dichtung	Joint plat	Junta
2061	Cassa esecuzione U	Housing version U	Gehäuse Version "U"	Carter U	Caja ejecucion U
2063	Disco portasatelliti	Planet disc carrier	Planetenträgerscheibe	Porte satellite	Disco portasatelites
2064	Albero variatore	Variator connecting shaft	Kupplungswelle	Arbre de liaison	Eje del variador
2066	Piede lavorato	Foot arrangement	Fuß	Patte	Pata mecanizada
2361	Coperchio collegamento	Connecting flange	Verbindungsflansch	Couvercle de liaison	Brida de fijacion
2362	Cassa riduzione R	Gear case	Gehäuse Vorstufe "R"	Carter R	Caja reduccion R
2363	Albero uscita	Output shaft	Abtriebswelle	Arbre de sortie	Eje de salida
2364	Guarnizione	Gasket	Dichtung	Joint plat	Junta
2365	Corona	Gear	Zahnrad	Couronne	Corona
2366	Pignone	Pinion gear	Ritzel	Pignon	Piñon
2370	Distanziale	Spacer ring	Distanzring	Entretoise	Distanciador
7369	Vite di collegamento	Connecting bolt	Verbindungsschraube	Vis	Tornillo de fijacion
7370	Vite di collegamento	Connecting bolt	Verbindungsschraube	Vis	Tornillo de fijacion

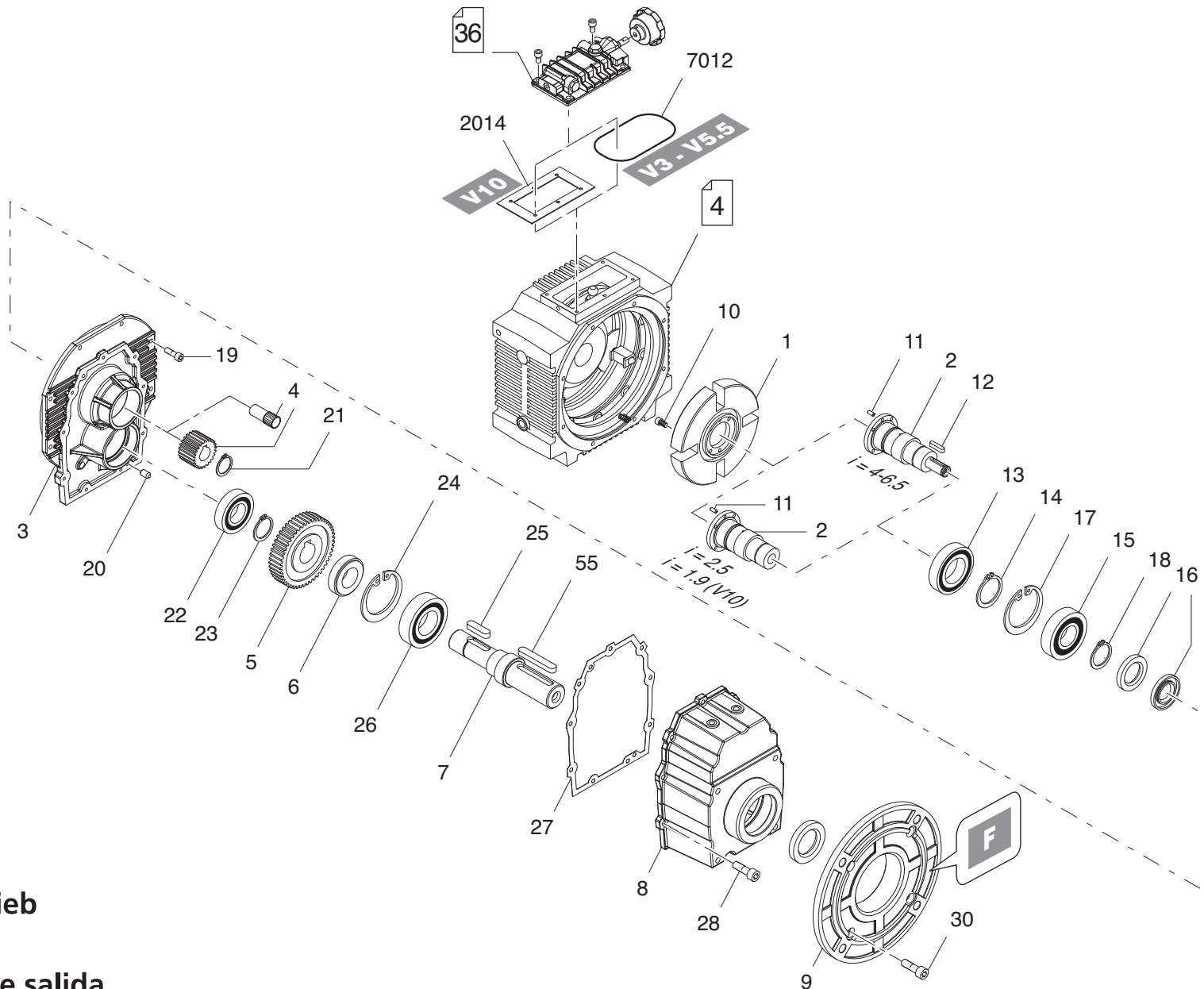



					 OR					
	7060	7061	7363	7364	7063	7067	7068	7365	7366	7069
VR 0.25 P	6204	6204 2RS	6005	6201	3225	16	20	11	17	47
VR 0.5 P	6204	6204 2RS	6005	6201	3256	16	20	11	17	47
VR 1 P	6206	—	6005	6202	3300	24	30	14	19	62
VR 2 P	6207	—	6206	6204	3375	28	35	18	24	72

									
	2367	2368	7066	7367	7070	7062	7361	7362	7371
VR 0.25 P	4x4x16	6x6x15	5x5x10	6x6x35	1/8" GAS	20x35x7	25x47x7	30x42x7	ø6x10
VR 0.5 P	4x4x16	6x6x15	5x5x10	6x6x35	1/8" GAS	20x35x7	25x47x7	30x42x7	ø6x10
VR 1 P	5x5x17.8	6x6x16	8x7x14	8x7x45	1/4" GAS	—	35x62x7	30x42x7	ø6x10
VR 2 P	6x6x20	8x7x19	8x7x18	8x7x50	1/4" GAS	—	40x72x7	35x52x7	ø6x10

**VR 3****VR 5.5****VR 10****Parti uscite****Output parts****Einzelteile Abtrieb****Pièces de sortie****Componentes de salida**

Pos.	Descrizione	Description	Benennung	Description	Descripción
1	Disco portasatelliti	Planet disc carrier	Planetenträgerscheibe	Porte satellite	Disco portasatelites
2	Albero disco	Shaft	Welle	Arbre de liaison	Eje disco
3	Coperchio collegamento	Connecting flange	Verbindungsflansch	Couvercle de liaison	Brida de union
4	Pignone	Pinion gear	Ritzel	Pignon	Piñon
5	Corona	Gear	Zahnrad	Couronne	Corona
6	Distanziale	Spacer ring	Distanzring	Entretoise	Distanciador
7	Albero uscita	Output shaft	Abtriebswelle	Arbre de sortie	Eje de salida
8	Cassa riduzione "R"	Gear case	Gehäuse Vorstufe "R"	Carter R	Caja reccion R
9	Flangia uscita	Mounting flange	Befestigungsflansch	Bride F	Brida de salida
11	Spina	Dowel pin	Passtift	Goupille cylindrique	Pasador
20	Spina	Dowel pin	Passtift	Goupille cylindrique	Pasador
27	Guarnizione	Gasket	Dichtung	Joint plat	Junta
2014	Guarnizione	Gasket	Dichtung	Joint plat	Junta



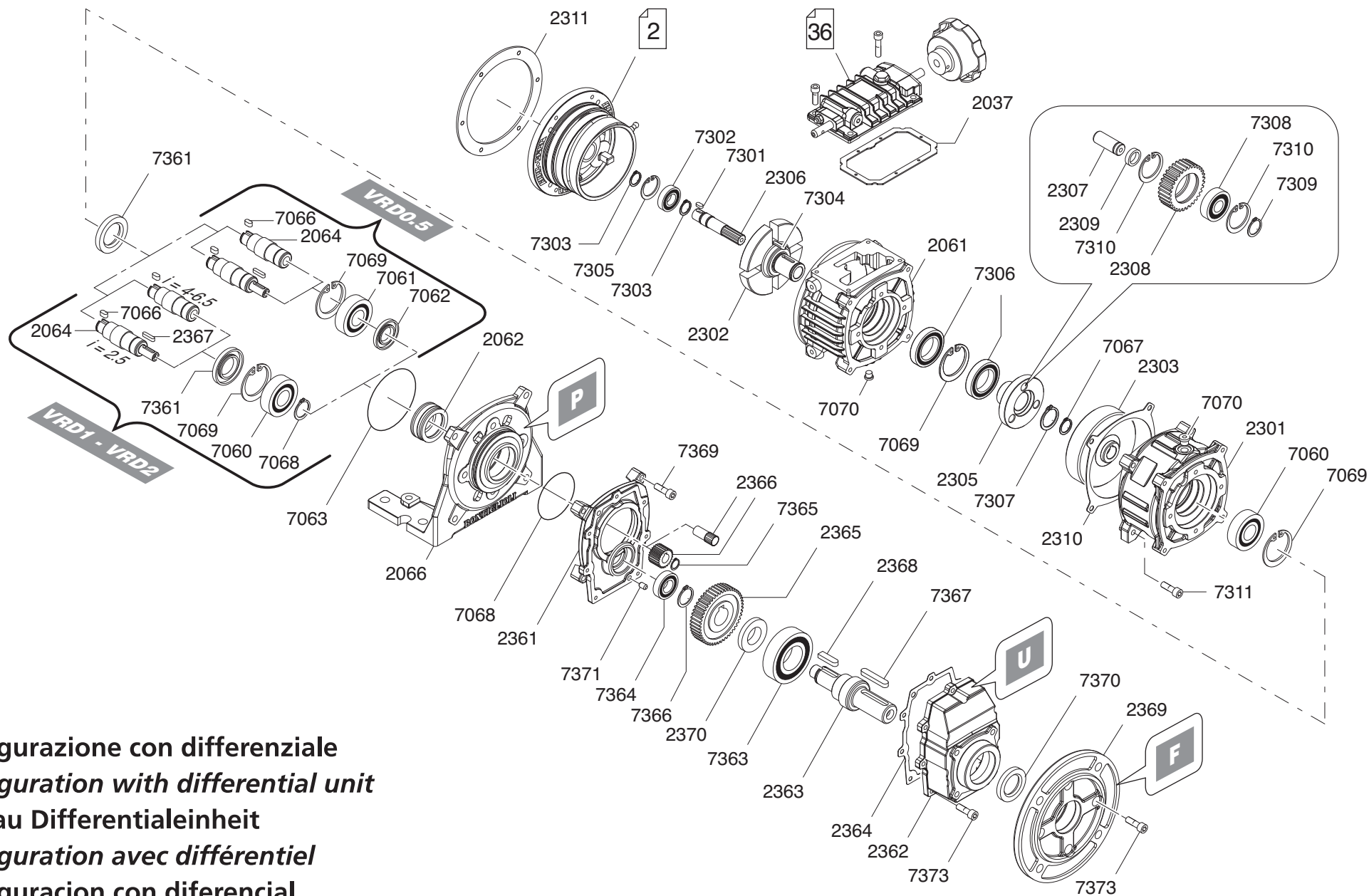

									
	10	13	15	22	26	19	28	30	OR 7012
VR 3	M6x18	6210	3208	6305	6306	M12x25	M6x22	M10x20	4462
VR 5.5	M6x18	6210	3208	6305	6306	M12x25	M6x22	M10x20	4462
VR 10	M6x14	6211	6309	6308	6310	M8x30	M8x30	M14x50	—





											
	12	25	14	18	21	23	16	29	55	17	24
VR 3	6x5.3x26	8x7x25	50	40	18	28	40x72x7	45x65x8	10x8x70	90	72
VR 5.5	6x5.3x26	8x7x25	50	40	18	28	40x72x7	45x65x8	10x8x70	90	72
VR 10	8x7x40	14x9x40	55	45	28	40	45x80x10	60x90x10	14x9x90	100	110



**Configurazione con differenziale**  
**Configuration with differential unit**  
**Aufbau Differentialeinheit**  
**Configuration avec différentiel**  
**Configuración con diferencial**

Pos.	Descrizione	Description	Benennung	Description	Descripción
2037	Guarnizione	Gasket	Dichtung	Joint plat	Junta
2061	Cassa variatore	Variator housing	Variatorgehäuse	Carter U	Caja variador
2062	Supporto per cuscinetto	Bearing sleeve	Lagerbuchse	Support de roulement	Soporte para rodamiento
2064	Albero	Shaft	Welle	Arbre de liaison	Eje
2301	Cassa differenziale	Differential housing	Differentialgehäuse	Carter de différentiel	Caja Diferencial
2302	Disco portasatelliti	Planet disc carrier	Planetenträgerscheibe	Porte satellite	Disco portasatelites
2303	Corona differenziale	Differential ring gear	Ringrad Differential	Couronne différentiel	Corona diferencial
2305	Albero porta ingranaggio	Planet gear carrier	Planetenradträger	Porte planétaire	Eje portaengranajes
2306	Albero con pignone	Pinionshaft	Ritzelwelle	Pignon arbré	Eje con piñon
2307	Perno porta satellite	Roller	Zapfen für Zahnrad	Axe de planétaire	Perno porta satellite
2308	Ingranaggio satellite	Planet gear	Planetenrad	Engrenage planétaire	Engranaje satellite
2309	Distanziale	Spacer ring	Distanzring	Entretoise	Distanciador
2310	Guarnizione cassa differenziale	Gasket	Gehäusedichtung	Joint plat	Junta caja diferencial
2311	Guarnizione	Gasket	Dichtung	Joint plat	Junta
2361	Coperchio collegamento	Connecting flange	Verbindungsflansch	Couvercle de liaison	Brida de union
2362	Cassa riduzione addizionale	Gear case	Getriebegehäuse	Carter R	Caja reduccion adicional
2363	Albero uscita	Output shaft	Abtriebswelle	Arbre de sortie	Eje de salida
2364	Guarnizione	Gasket	Dichtung	Joint plat	Junta
2365	Corona	Gear	Zahnrad	Couronne	Corona
2366	Pignone	Pinion gear	Ritzel	Pignon	Piñon
2369	Flangia uscita	Output flange	Abtriebsflansch	Bride F	Brida de salida
2370	Distanziale	Spacer ring	Distanzring	Entretoise	Distanciador
7311	Vite di collegamento	Connecting bolt	Verbindungsschraube	Vis	Tornillo de fijacion
7369	Vite di collegamento	Connecting bolt	Verbindungsschraube	Vis	Tornillo de fijacion
7373	Vite di collegamento	Connecting bolt	Verbindungsschraube	Vis	Tornillo de fijacion

												
	7060	7061	7302	7306	7308	7363	7364	OR 7063	7070	7304	7066	7371
<b>VRD 0.5</b>	6204	6204	16002	61906	6000	6005	6201	3256	1/8" GAS	4x4x20	5x5x10	ø6x10
<b>VRD 1</b>	6206	—	16004	61908	6000	6005	6202	3300	1/4" GAS	5x5x25	8x7x14	ø6x10
<b>VRD 2</b>	6207	—	16005	61910	6202	6206	6204	3375	1/4" GAS	5x5x25	8x7x18	ø6x10

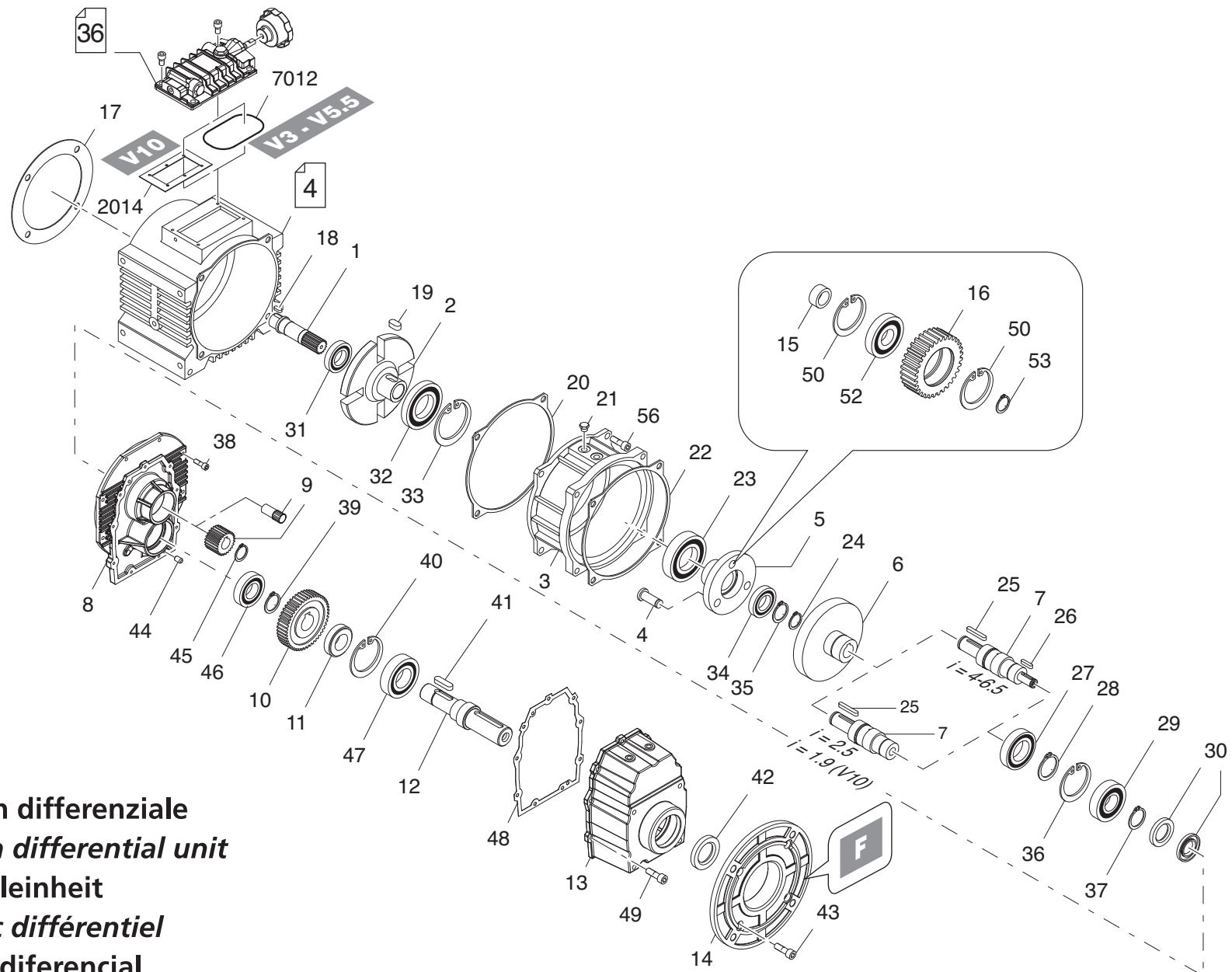

																	
	2367	2368	7066	7301	7367	7067	7068	7303	7307	7309	7366	7069	7305	7310	7062	7361	7370
<b>VRD 0.5</b>	4x4x16	6x6x15	5x5x10	5x4.5x10	6x6x35	16	20	15	24	10	17	47	32	26	25x35x7	25x47x7	30x42x7
<b>VRD 1</b>	5x5x17.8	6x6x16	8x7x14	6x5.5x12	8x7x45	24	30	20	29	10	19	62	42	26	—	35x62x7	30x42x7
<b>VRD 2</b>	6x6x20	8x7x19	8x7x18	8x6.5x13	8x7x50	28	35	25	35	15	24	72	47	35	—	40x72x7	35x52x7





**Configurazione con differenziale**  
**Configuration with differential unit**  
**Aufbau Differentialeinheit**  
**Configuration avec différentiel**  
**Configuración con diferencial**



Pos.	Descrizione	Description	Benennung	Description	Descripción
1	Albero	Shaft	Welle	Pignon arbré	Eje
2	Disco portasatelliti	Planet disc carrier	Planetenträgerscheibe	Porte satellite	Disco portasatelites
3	Cassa differenziale	Differential housing	Differentialgehäuse	Carter de différentiel	Caja diferencial
4	Perno satelliti differenziale	Planet gear roller	Zapfen für Planetenrad	Axe de planétaire	Perno satelites diferencial
5	Disco motore	Tapered sun disc	Antriebscheibe	Porte planétaire	Disco motor
6	Corona differenziale	Differential ring gear	Ringrad Differential	Couronne différentiel	Corona diferencial
7	Albero	Shaft	Welle	Arbre de liaison	Eje
8	Coperchio di collegamento	Connecting flange	Verbindungsflansch	Couvercle de liaison	Brida de union
9	Pignone	Pinion gear	Ritzelwelle	Pignon	Piñon
10	Corona	Gear	Zahnrad	Couronne différentiel	Corona
11	Anello distanziale	Spacer ring	Distanzring	Entretoise	Anillo distanciadador
12	Albero uscita	Output shaft	Abtriebswelle	Arbre de sortie	Eje de salida
13	Scatola riduzione aggiuntiva	Gear case	Getriebegehäuse	Carter R	Caja de reduccion postiza
14	Flangia di fissaggio	Mounting flange	Befestigungsflansch	Bride F	Brida de fijacion
15	Anello distanziale	Spacer ring	Distanzring	Entretoise	Anillo distanciadador
16	Ingranaggio differenziale	Planet gear	Planetenrad	Engrenage planétaire	Engranaje diferencial
17	Guarnizione	Gasket	Dichtung	Joint plat	Junta
18	Linguetta	Key	Passfeder	Clavette	Chaveta
19	Linguetta	Key	Passfeder	Clavette	Chaveta
20	Guarnizione	Gasket	Dichtung	Joint plat	Junta
21	Tappo	Plug	Verschluß	Bouchon	Tapon
22	Guarnizione	Gasket	Dichtung	Joint plat	Junta
44	Spina	Dowel pin	Passtift	Goupille cylindrique	Pasador
48	Guarnizione	Gasket	Dichtung	Joint plat	Junta
2014	Guarnizione	Gasket	Dichtung	Joint plat	Junta
7012	O-ring	O-ring	O-Ring	Joint torique	Junta torica





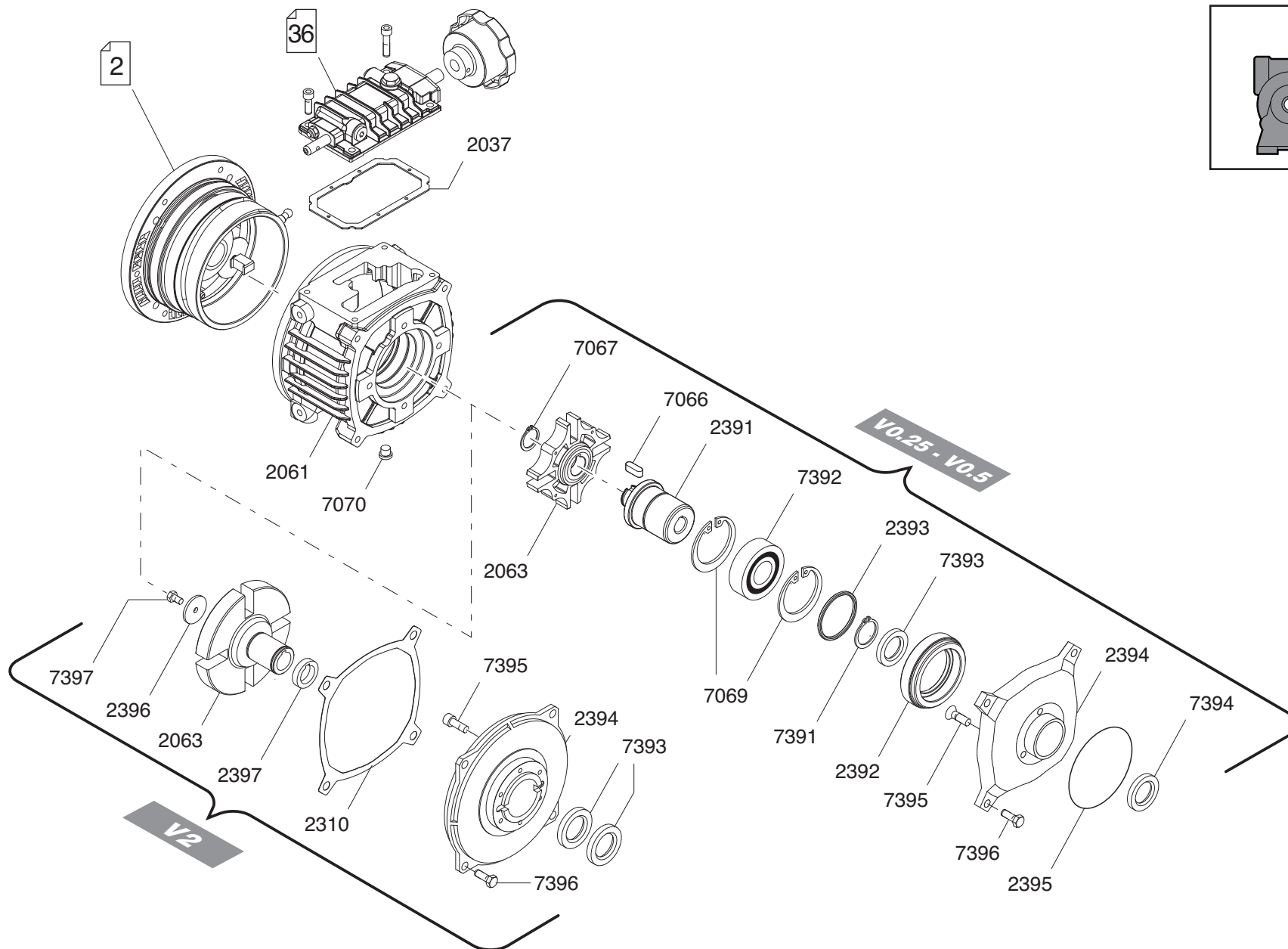

																	
	23	27	29	31	32	34	46	47	52	30	42	38	43	49	55	56	
<b>VRD 3</b>	6011	6210	3208	6006	16011	6206	6305	6306	6303	40x72x7	45x65x8	M12x25	M10x20	M6x22	10x8x70	M12x25	
<b>VRD 5.5</b>	6011	6210	3208	6006	16011	6206	6305	6306	6303	40x72x7	45x65x8	M12x25	M10x20	M6x22	10x8x70	M12x25	
<b>VRD 10</b>	6011	6211	6309	6206	6011	6206	6308	6310	6303	45x80x10	60x90x10	M8x30	M14x50	M8x30	14x9x90	M8x30	

																	
	18	19	25	26	41	24	28	35	37	39	45	53	33	36	40	50	
<b>VRD 3</b>	8x6.5x18	6x6x30	8x7x50	6x5.3x26	8x7x25	28	50	30	40	28	18	17	90	90	72	47	
<b>VRD 5.5</b>	8x6.5x18	6x6x30	8x7x50	6x5.3x26	8x7x25	28	50	30	40	28	18	17	90	90	72	47	
<b>VRD 10</b>	10x7.5x20	6x6x30	10x8x65	8x7x40	14x9x40	35	55	30	45	40	28	17	90	100	110	47	





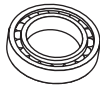

Pos.	Descrizione	Description	Benennung	Description	Descripción
2037	Guarnizione	Gasket	Dichtung	Joint plat	Junta
2061	Cassa	Housing	Gehäuse	Carter	Caja
2063	Disco portasatelliti	Planet disc carrier	Planetenträgerscheibe	Porte satellite	Disco portasatelites
2310	Guarnizione cassa	Gasket	Gehäusedichtung	Joint plat	Junta
2391	Albero uscita	Output shaft	Abtriebswelle	Arbre de sortie	Eje de salida
2392	Supporto uscita	Support sleeve	Halterung	Support	Casquillo soporte
2393	Distanziale	Spacer ring	Distanzring	Entretoise	Distanciador
2394	Flangia di collegamento	Connecting flange	Verbindungsflansch	Bride de liaison	Brida de fijacion
2395	Guarnizione OR	O-ring	O-Ring	Joint torique	Junta torica
2396	Rondella	Washer	Scheibe	Rondelle	Arandela
2397	Distanziale	Spacer ring	Distanzring	Entretoise	Distanciador
7395	Vite di collegamento	Connecting bolt	Verbindungsschraube	Vis	Tornillo de fijacion
7396	Vite di collegamento	Connecting bolt	Verbindungsschraube	Vis	Tornillo de fijacion

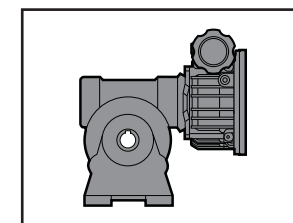
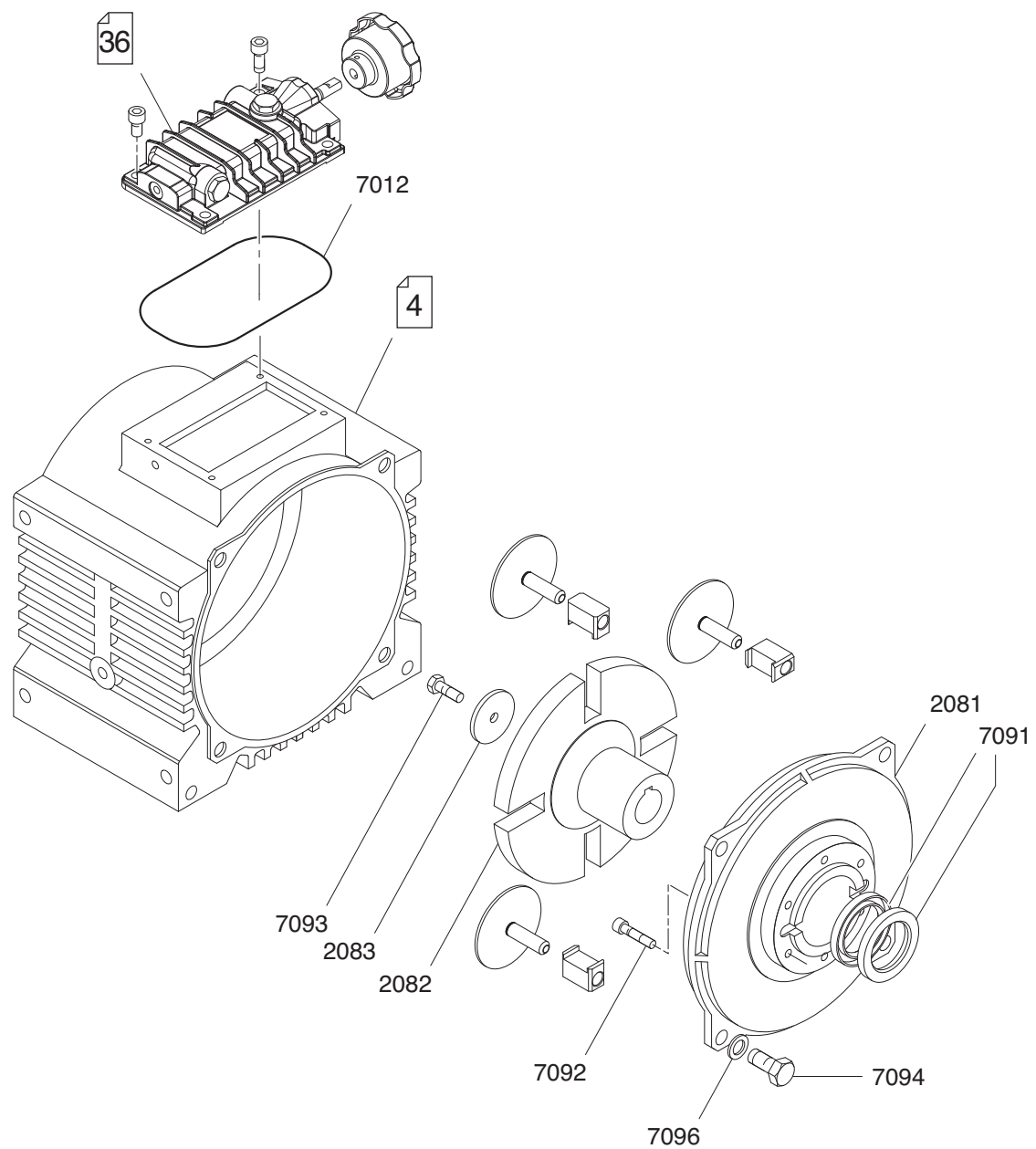
									
	<b>7066</b>	<b>7069</b>	<b>7070</b>	<b>7391</b>	<b>7067</b>	<b>7392</b>	<b>7393</b>	<b>7394</b>	<b>7397</b>
<b>V 0.25 C</b>	5x5x10	47	1/8" GAS	30	16	61906	30x47x7	15x30x4.5	—
<b>V 0.5 C</b>	5x5x10	47	1/8" GAS	30	16	61906	30x47x7	20x30x7	—
<b>V 2 C</b>	—	—	1/4" GAS	—	—	—	35x67x7	—	M8x25







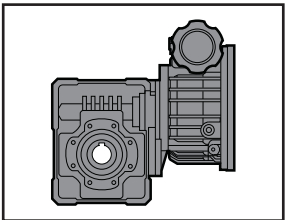
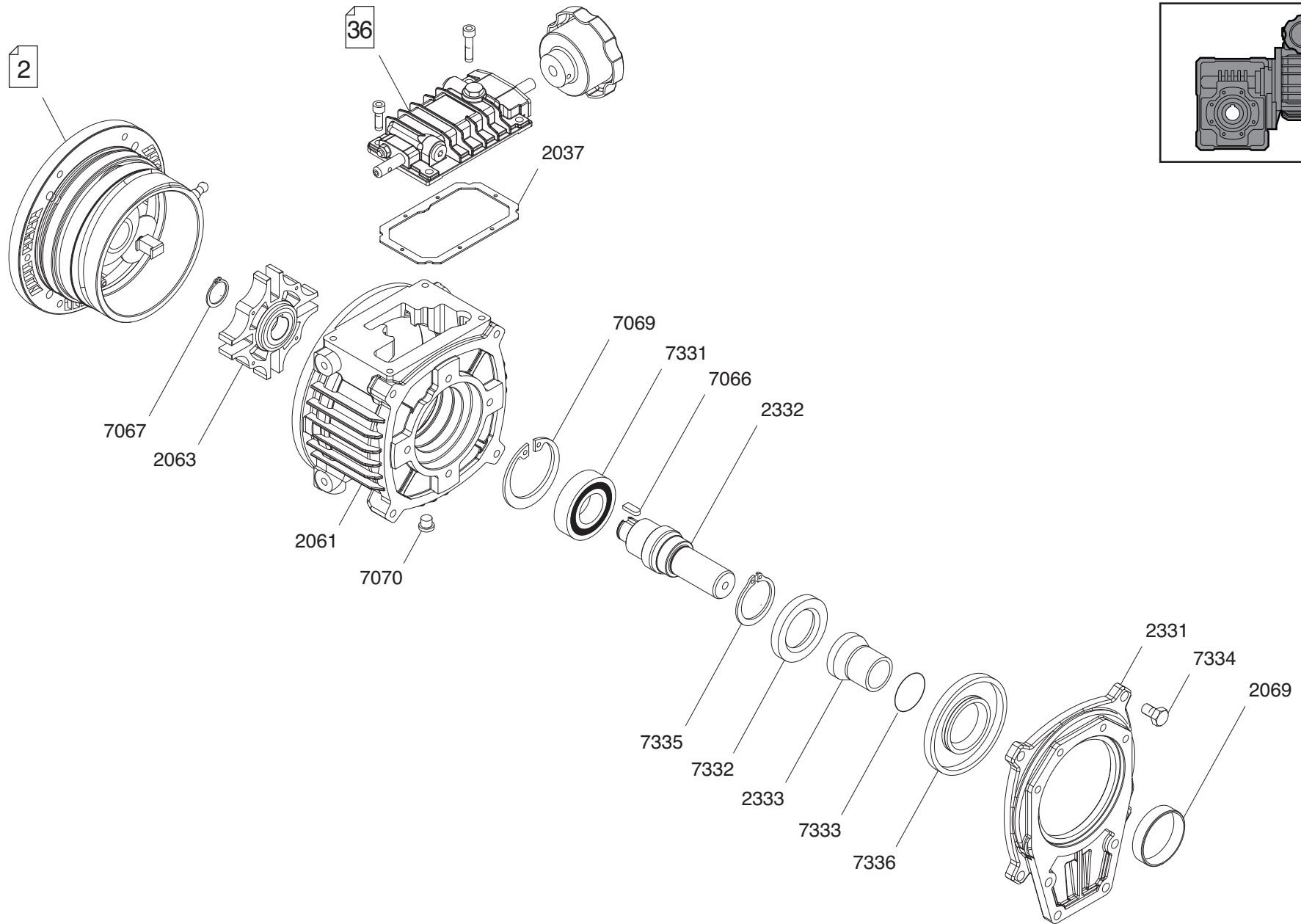

Pos.	Descrizione	Description	Benennung	Description	Descripción
2081	Coperchio di collegamento	Connecting flange	Verbindungsflansch	Bride de liaison	Brida de union
2082	Disco uscita portasatelliti	Planet disc carrier	Planetenträgerscheibe	Porte satellite	Disco portasatelites a la salida
2083	Rondella	Washer	Scheibe	Rondelle	Arandela
7092	Vite di collegamento	Connecting bolt	Verbindungsschraube	Vis	Tornillo de fijacion
7094	Vite di collegamento	Connecting bolt	Verbindungsschraube	Vis	Tornillo de fijacion
7096	Rosetta	Washer	Scheibe	Rondelle	Arandela

	 OR	 7091			
	<b>7012</b>	<b>VF 110</b>	<b>VF 130</b>	<b>VF 150</b>	<b>7093</b>
<b>V 3 C</b>	4462	30x62x7	35x62x7	40x72x7	M8x22
<b>V 5.5 C</b>	4462	30x62x7	35x62x7	40x72x7	M8x22



Pos.	Descrizione	Description	Benennung	Description	Descripción
2037	Guarnizione	Gasket	Dichtung	Joint plat	Junta
2061	Cassa	Housing	Gehäuse	Carter	Caja
2063	Disco portasatelliti	Planet disc carrier	Planetenträgerscheibe	Porte satellite	Disco portasatelites
2069	Distanziale	Spacer ring	Distanzring	Entretoise	Distanciador
2331	Coperchio di collegamento	Connecting flange	Verbindungsflansch	Bride de liaison	Tapa de union
2332	Albero uscita	Output shaft	Abtriebswelle	Arbre de sortie	Eje de salida
2333	Boccola	Bushing	Buchse	Bague	Casquillo
7334	Vite di collegamento	Connecting bolt	Verbindungsschraube	Vis	Tornillo de fijacion

									
	7066	7067	7335	7069	7070	7331	7332	7336	7333
V 0.5 C	5x5x10	16	—	47	1/8" GAS	6005	30x47x7	—	4134
V 1 C	8x7x14	24	—	62	1/4" GAS	6007	40x62x7	—	4131
V 2 C	8x7x18	28	50	72	1/4" GAS	61910	50x72x8	50x80x8	4150

V 0.25 C

V 0.5 C

V 1 C





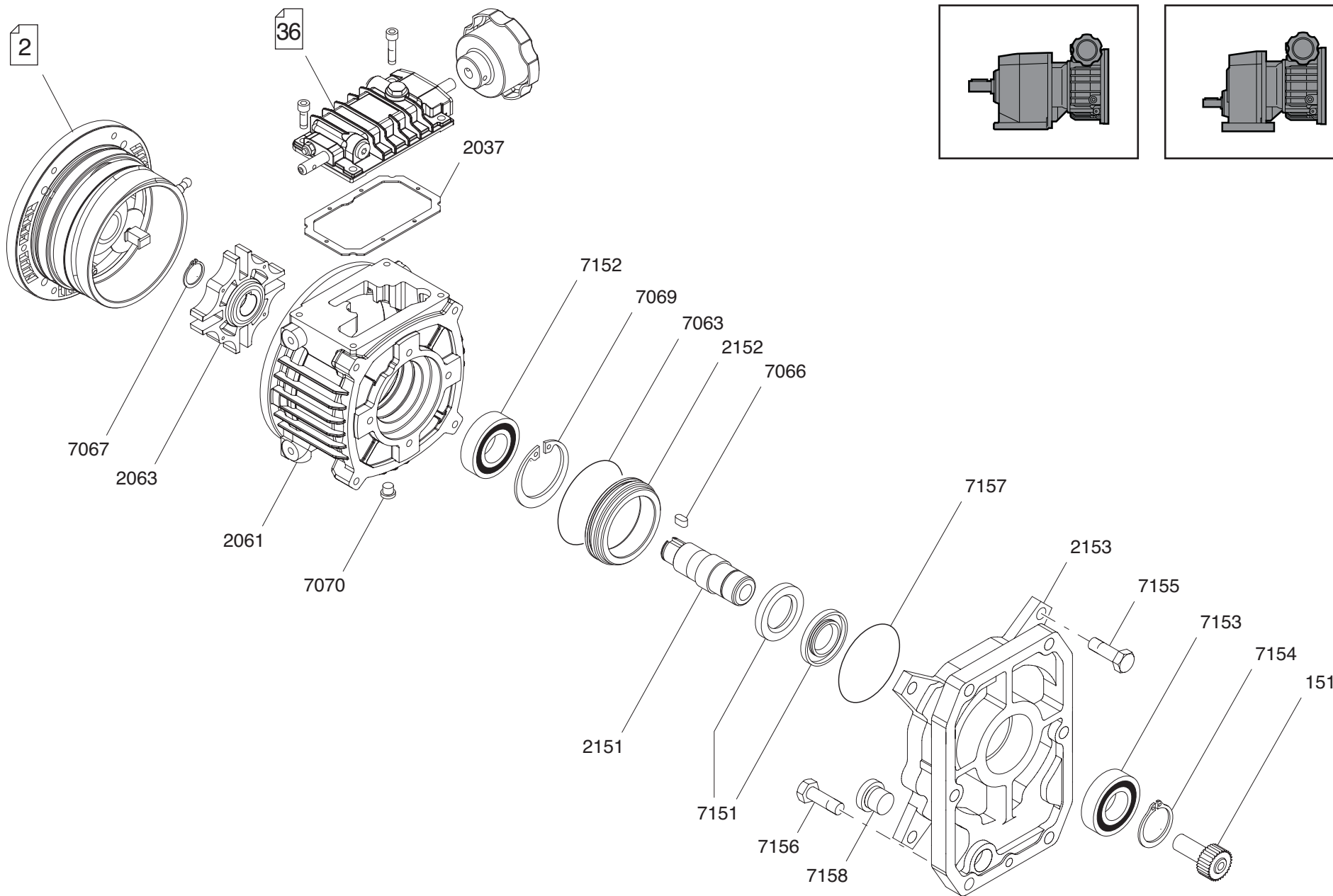

V 2 C

C+V

S+V



Pos.	Descrizione	Description	Benennung	Description	Descripción
151	Pignone elicoidale	Helical pinion gear	Ritzel	Pignon hélicoïdal	Piñon helicoidal
2037	Guarnizione	Gasket	Dichtung	Joint plat	Junta
2061	Cassa	Housing	Gehäuse	Carter	Caja
2063	Disco portasatelliti	Planet disc carrier	Planetenträgerscheibe	Porte satellite	Disco porta satelites
2151	Albero di collegamento	Connecting shaft	Kupplungswelle	Arbre de liaison	Eje de union
2152	Supporto uscita	Support sleeve	Halterung	Support	Soporte de salida
2153	Coperchio di collegamento	Connecting flange	Verbindungsflansch	Bride de liaison	Tapa de union
7155	Vite di collegamento	Connecting bolt	Verbindungsschraube	Vis	Tornillo de fijacion
7156	Vite di collegamento	Connecting bolt	Verbindungsschraube	Vis	Tornillo de fijacion

	 OR													
	7063	7157	7066	7067	7154	7069	7070	7158	7151	7152	7153			
<b>V 0.25 C</b>	3225	2175	5x5x10	16	17	47	1/8" GAS	1/4" GAS	20x35x7	6204	6203			
<b>V 0.5 C</b>	3256	2175	5x5x10	16	17	47	1/8" GAS	1/4" GAS	20x35x7	6204	6203			
<b>V 1 C</b>	3300	—	8x7x14	24	30	62	1/4" GAS	1/4" GAS	35x52x7	6206	6206			
<b>V 2 C</b>	3375	—	8x7x18	28	35	72	1/4" GAS	1/4" GAS	40x62x7	6207	6207			

V 3 C

V 5.5 C

V 10 C





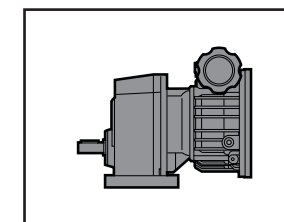
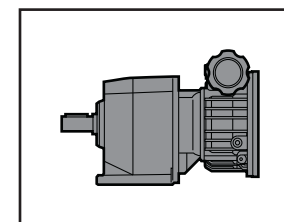
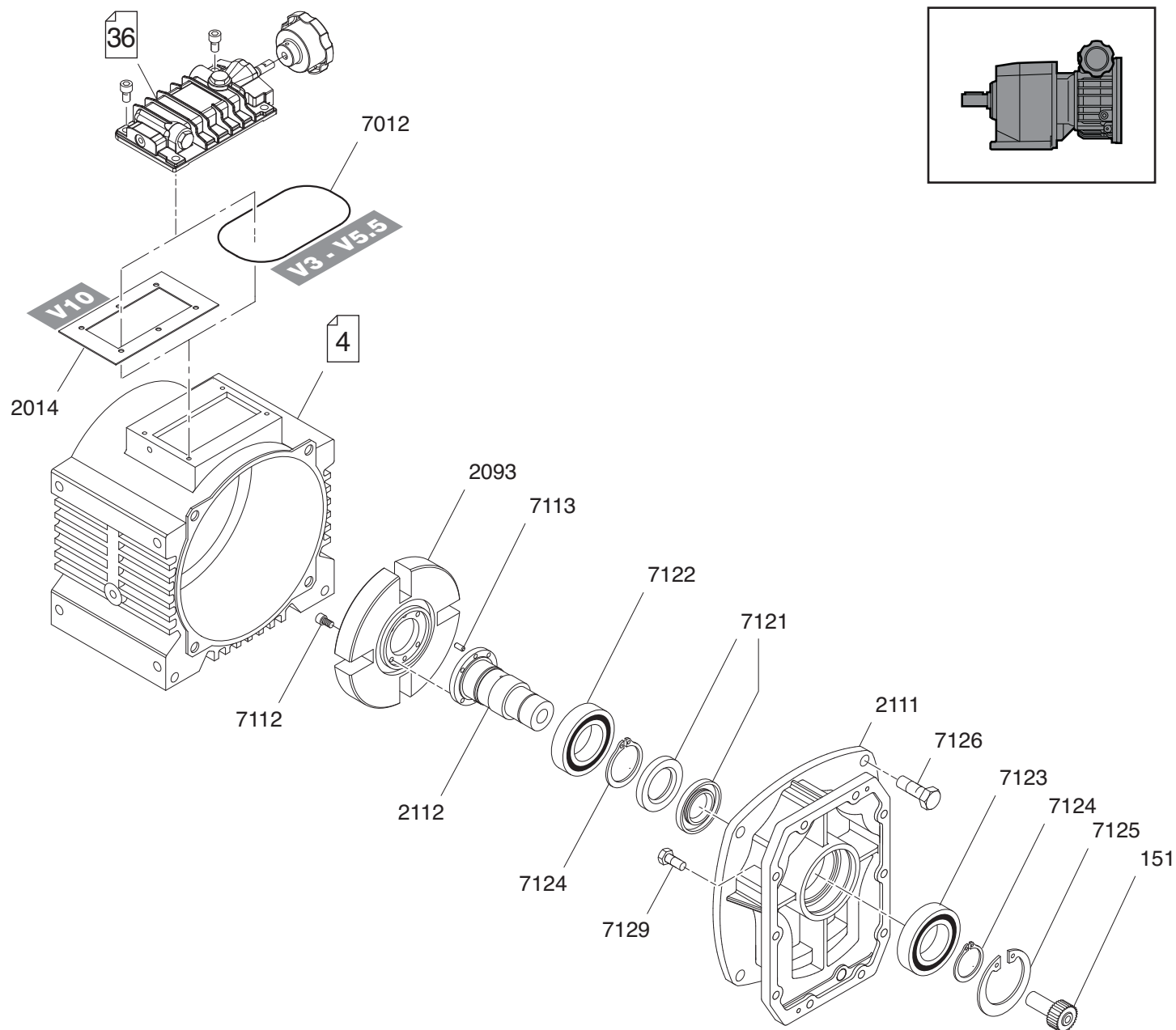

C+V

S+V



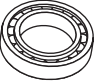
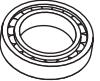

Pos.	Descrizione	Description	Benennung	Description	Descripción
151	Pignone elicoidale	Helical pinion gear	Ritzel	Pignon hélicoïdal	Piñon helicoidal
2014	Guarnizione	Gasket	Dichtung	Joint plat	Junta
2093	Disco portasatelliti	Planet disc carrier	Planetenträgerscheibe	Porte satellite	Disco portasatelites
2111	Coperchio di collegamento	Connecting flange	Verbindungsflansch	Bride de liaison	Tapa de union
2112	Albero di collegamento	Connecting shaft	Verbindungswelle	Arbre de liaison	Eje de union
7126	Vite di collegamento	Connecting bolt	Verbindungsschraube	Vis	Tornillo de fijacion
7129	Vite di collegamento	Connecting bolt	Verbindungsschraube	Vis	Tornillo de fijacion

	 OR	 7012	 7113	 7121	 7122	 7123	 7124	 7125
<b>V 3 C</b>	4462	M6x12	∅6x16	50x72x8	6210	6308	40	90
<b>V 5.5 C</b>	4462	M6x12	∅6x16	50x72x8	6210	6308	40	90
<b>V 10 C</b>	—	M8x14	∅8x16	55x80x8	6211	6309	45	—

V 0.25

V 0.5

V 1

V 2

V 3

V 5.5



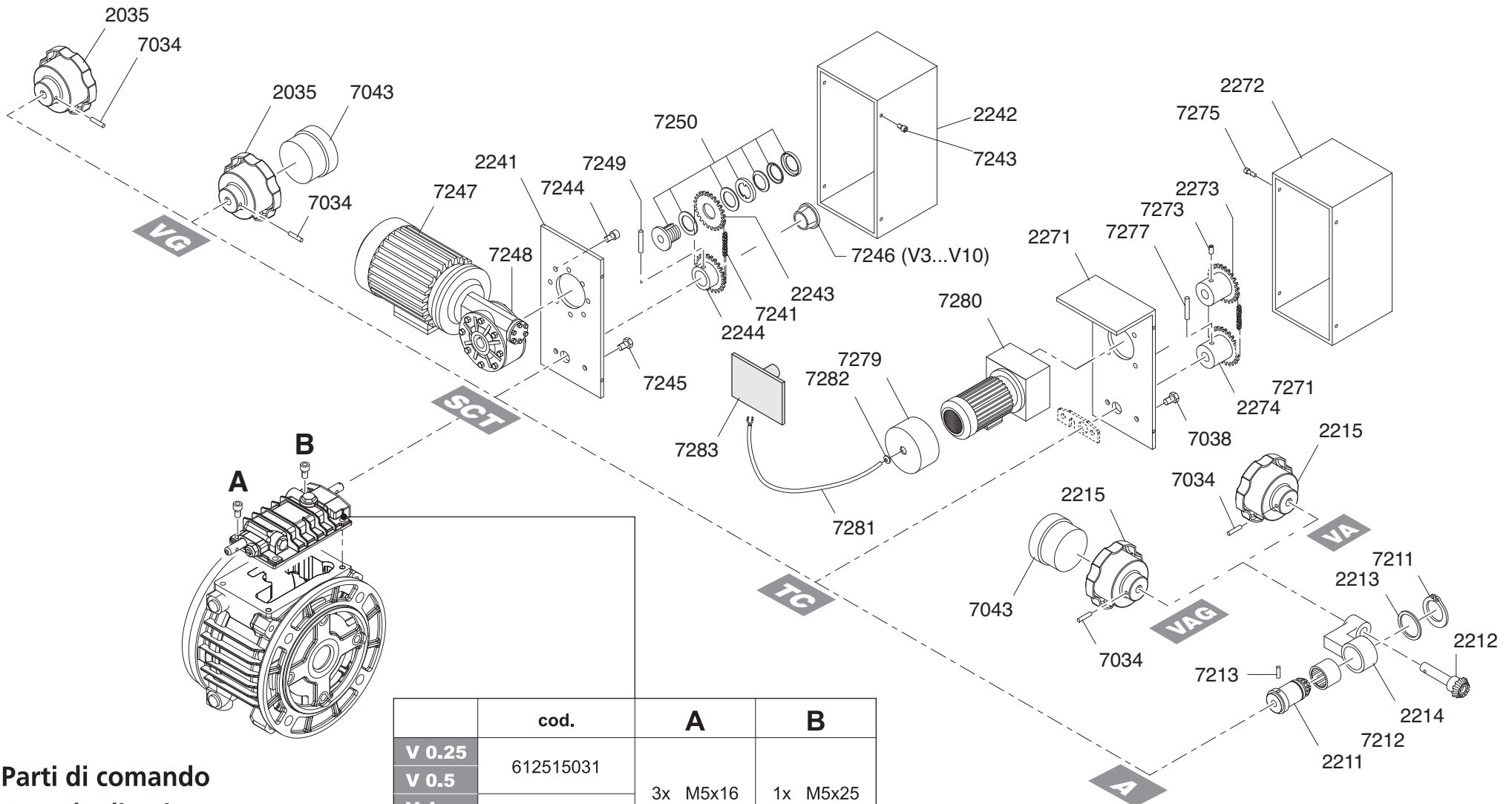





V 10



Parti di comando  
 Speed adjusting parts  
 Einzelteile Verstelleinrichtung  
 Accessoires de commande  
 Partes del mando

	cod.	A	B
V 0.25	612515031	3x M5x16	1x M5x25
V 0.5			
V 1	612515029		
V 2			
V 3	612515026	4x M6x18	
V 5.5			
V 10	612515019	6x M6x25	

Pos.	Descrizione	Description	Benennung	Description	Descripción
2035	Volantino di comando	Handwheel	Handrad	Volant de commande	Volante de regulacion
2211	Pignone condotto	Driven pinion	Abtriebsritzel	Pignon conduit	Piñon conducido
2212	Pignone conduttore	Drive pinion	Antriebsritzel	Pignon menant	Piñon conductor
2213	Distanziale	Spacer	Distanzring	Entretoise	Distanciadore
2214	Corpo	Support	Aufnahme	Support	Cuerpo
2215	Volantino di comando	Handwheel	Handrad	Volant de commande	Volante de regulacion
2241	Staffa di supporto	Bracket	Montageplatte	Platine	Cartela de soporte
2242	Coperchio	Safety cover	Schutzhaube	Couvercle	Tapa
2243	Pignone conduttore	Drive pinion	Antriebsritzel	Pignon conduit	Piñon conductor
2244	Pignone condotto	Driven pinion	Abtriebsritzel	Pignon menant	Piñon conducido
2271	Staffa di supporto	Bracket	Montageplatte	Platine	Cartela de soporte
2272	Coperchio di chiusura	Safety cover	Schutzhaube	Couvercle	Tapa de cierre
2273	Pignone conduttore	Drive pinion	Antriebsritzel	Pignon conduit	Piñon conductor
2274	Pignone condotto	Driven pinion	Abtriebsritzel	Pignon menant	Piñon conducido
7038	Vite di fissaggio	Screw	Schraube	Vis	Tornillo de fijacion
7043	Indicatore di giri	Turns indicator	Schleppanzeige	Indicateur gravitationel	Indicador de vueltas
7241	Catena	Chain	Kette	Chaîne	Cadena
7243	Vite di fissaggio	Screw	Schraube	Vis	Tornillo de fijacion
7244	Vite di fissaggio	Screw	Schraube	Vis	Tornillo de fijacion
7245	Vite di fissaggio	Screw	Schraube	Vis	Tornillo de fijacion
7246	Calettatore	Cone clamping	Spannbüchse	Moyeu de serrage	Aro conico de apriete
7247	Motore	Motor	Motor	Moteur	Motor
7248	Riduttore	Gear unit	Getriebe	Réducteur	Reductor
7250	Limitatore di coppia	Torque limiter	Rutschkupplung	Limiteur de couple	Limitador de par
7271	Catena	Chain	Kette	Chaîne	Cadena
7275	Vite di fissaggio	Screw	Schraube	Vis	Tornillo de fijacion
7279	Tappo di plastica	Plastic cover	Kunststoffhaube	Bouchon plastique	Tapon de plastico
7280	Motore	Motor	Motor	Moteur	Motor
7281	Guaina	Sheath	Ummantelung	Gaine	Proteccion
7282	Pressacavo	Cable gland	Kabelverschraubung	Presse étoupe	Prensaestopas
7283	Scheda elettronica	Electronic board	Elektronikkarte	Carte électronique	Tarjeta electronica

															
	7034	7213	7249	7277	7211	7212	7273		7034	7213	7249	7277	7211	7212	7273
V 0.25								V 3							
V 0.5								V 5.5	ø4x30	ø4x30	ø4x30	ø4x26	26	20x30x17	M4x5
V 1								V 10							
V 2	ø4x30	ø4x30	4x30ø	ø4x26	26	20x30x17	M4x5								

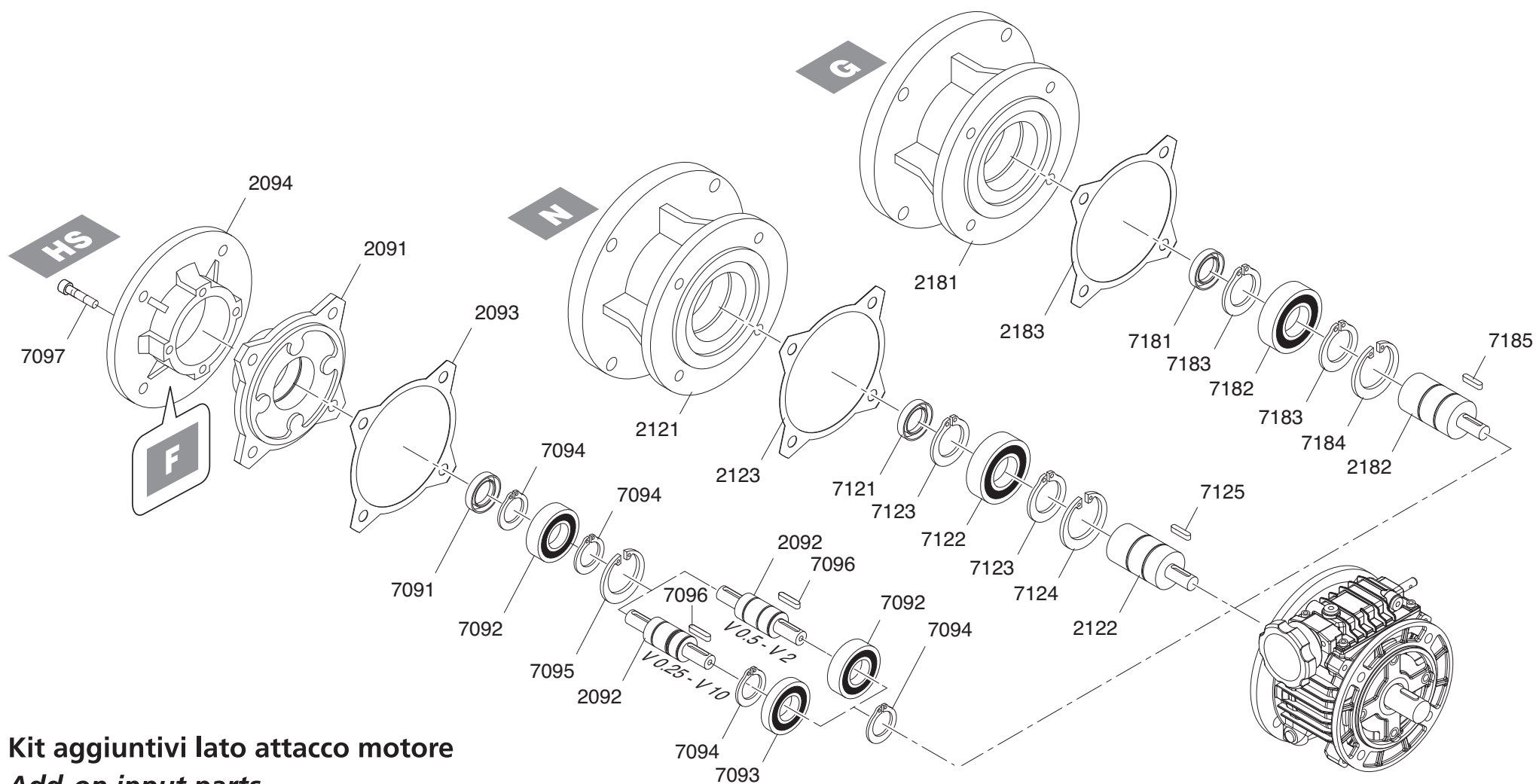

**Kit aggiuntivi lato attacco motore**



**Add-on input parts**

**Zusätzliche Eingangsbaugruppen**

**Kits d'entrée**

**Kit a añadir en el lado fijacion motor**

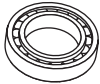
Pos.	Descrizione	Description	Benennung	Description	Descripción
2091	Coperchio entrata	Front cover	Frontdeckel	Couvercle d'entrée	Tapa de entrada
2092	Albero entrata	Input shaft	Eingangswelle	Arbre d'entrée	Eje de entrada
2093	Guarnizione entrata	Gasket	Dichtung	Joint plat	Junta de entrada
2094	Flangia	Flange	Flansch	Bride	Brida
2121	Flangia attacco motore	Motor mounting flange	Motorbefestigungsflansch	Bride moteur	Brida fijacion motor
2122	Albero entrata cavo	Hollow input shaft	Eingangshohlwelle	Arbre d'entrée creux	Eje de entrada hueco
2123	Guarnizione entrata	Gasket	Dichtung	Joint plat	Junta de entrada
2181	Flangia attacco motore	Motor mounting flange	Motorbefestigungsflansch	Bride moteur	Brida fijacion motor
2182	Albero entrata cavo	Hollow input shaft	Eingangshohlwelle	Arbre d'entrée creux	Eje de entrada hueco
2183	Guarnizione entrata	Gasket	Dichtung	Joint plat	Junta de entrada
7097	Vite di collegamento	Connecting bolt	Verbindungsschraube	Vis	Tornillo de fijacion

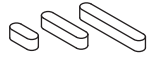
																
	7091	7121	7181	7092	7093	7122	7182	7094	7123	7183	7095	7124	7184	7096	7125	7185
<b>V 0.25</b>	20x30x7	30x40x7	20x40x7	16004	6004	6006	6005	20	30	25	42	55	47	4x4x20	4x4x20	4x4x20
<b>V 0.5</b>	30x42x7	30x42x7	35x52x7	—	16006	6006	6007	30	30	35	55	55	62	5x5x25	5x5x25	5x5x25
<b>V 1</b>	35x52x7	35x52x7	40x62x7	6007	16007	6007	6208	35	35	40	62	62	80	6x6x20	6x6x30	6x6x30
<b>V 2</b>	40x62x7	40x62x7	45x72x8	6208	—	6208	6209	40	40	45	80	80	85	8x7x40	6x6x30	8x7x40
<b>V 3</b>	45x72x8	45x72x8	55x80x8	6209	6209	6209	6211	45	45	55	85	85	100	8x7x50	8x7x50	8x7x50
<b>V 5.5</b>	45x72x8	45x72x8	55x80x8	6209	6209	6209	6211	45	45	55	85	85	100	8x7x50	8x7x50	8x7x50
<b>V 10</b>	45x80x10	55x80x8	60x90x10	6309	6309	6211	6212	45	55	60	100	100	110	10x8x70	10x8x70	10x8x70

## R0

	Descrizione	Description	Benennung	Description	Descripción

111124

Questa pubblicazione annulla e sostituisce ogni precedente edizione o revisione. Ci riserviamo il diritto di apportare modifiche senza preavviso. E' vietata la riproduzione anche parziale senza autorizzazione.

*This publication cancels and replaces any previous edition and revision. We reserve the right to implement modifications without notice. This catalogue cannot be reproduced, even partially, without prior consent.*

Diese Veröffentlichung annulliert und ersetzt jeder hergehende Edition oder Revision. BONFIGLIOLI behält sich das Recht vor, Änderungen ohne vorherige Informationen durchzuführen.

*Cette publication annule et remplace toutes les autres précédentes. Nous nous réservons le droit d'apporter toutes modifications à nos produits. La reproduction et la publication partielle ou totale de ce catalogue est interdite sans a autorisation.*

Esta publicación anula y sustituye toda anterior edición o revisión. Nos reservamos el derecho de aportar modificaciones sin previo aviso. Se prohíbe la reproducción incluso parcial sin autorización.





Dal 1956 Bonfiglioli progetta e realizza soluzioni innovative ed affidabili per il controllo e la trasmissione di potenza nell'industria e nelle macchine operatrici semoventi e per le energie rinnovabili.

Bonfiglioli has been designing and developing innovative and reliable power transmission and control solutions for industry, mobile machinery and renewable energy applications since 1956.

Seit 1956 plant und realisiert Bonfiglioli innovative und zuverlässige Lösungen für die Leistungsüberwachung und -übertragung in industrieller Umgebung und für selbstfahrende Maschinen sowie Anlagen im Rahmen der erneuerbaren Energien.

Depuis 1956, Bonfiglioli conçoit et réalise des solutions innovantes et fiables pour le contrôle et la transmission de puissance dans l'industrie et dans les machines automotrices et pour les énergies renouvelables.

Bonfiglioli diseña y crea soluciones de control y transmisión de potencia innovadoras y fiables para la industria, las máquinas autopropulsadas y la producción de energías renovables desde 1956.