

Bonfiglioli Riduttori

iBMD

Servomotor with integrated drive

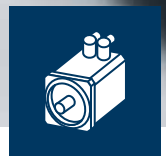
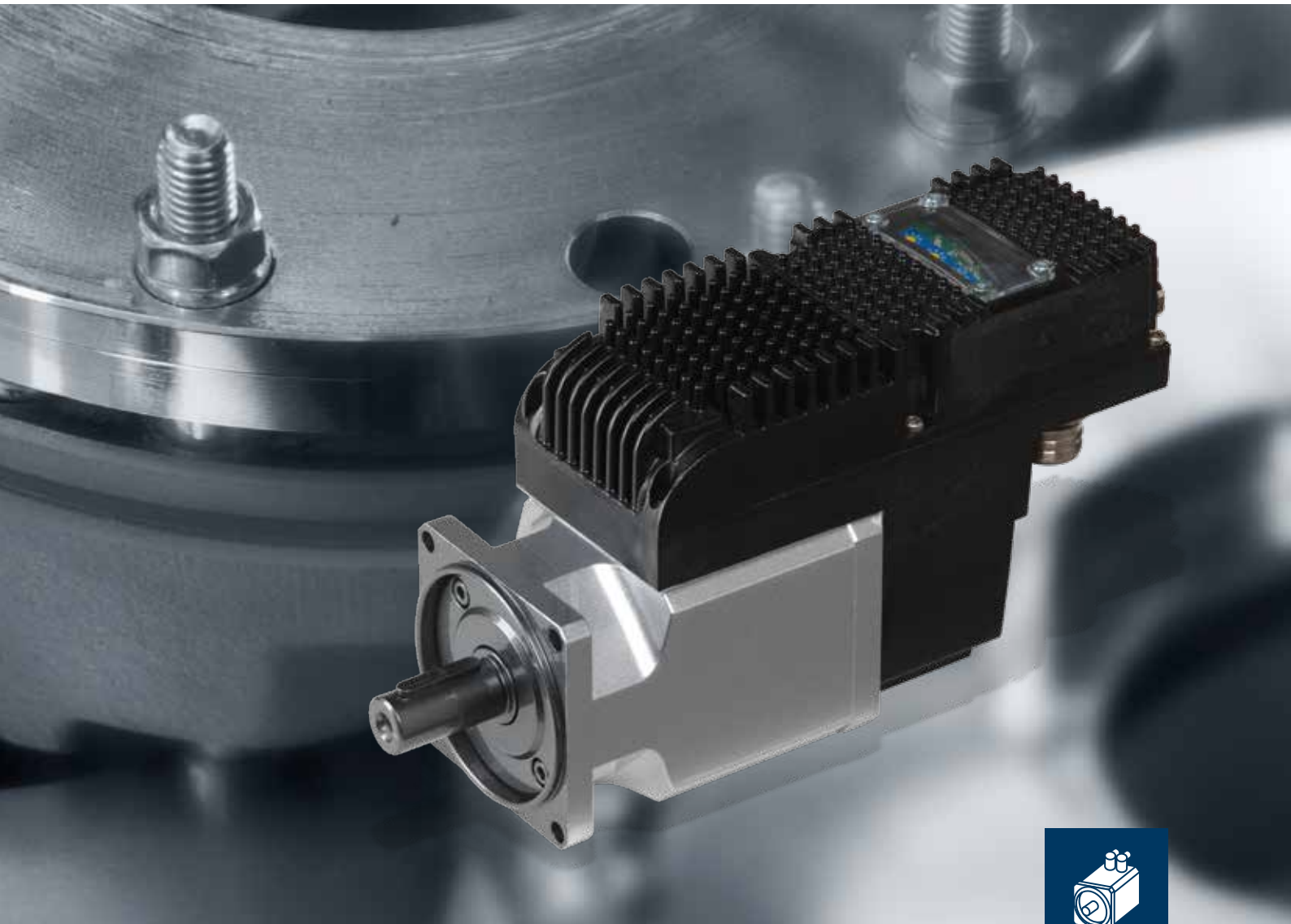

PRODUCT

 **Bonfiglioli**
Forever Forward

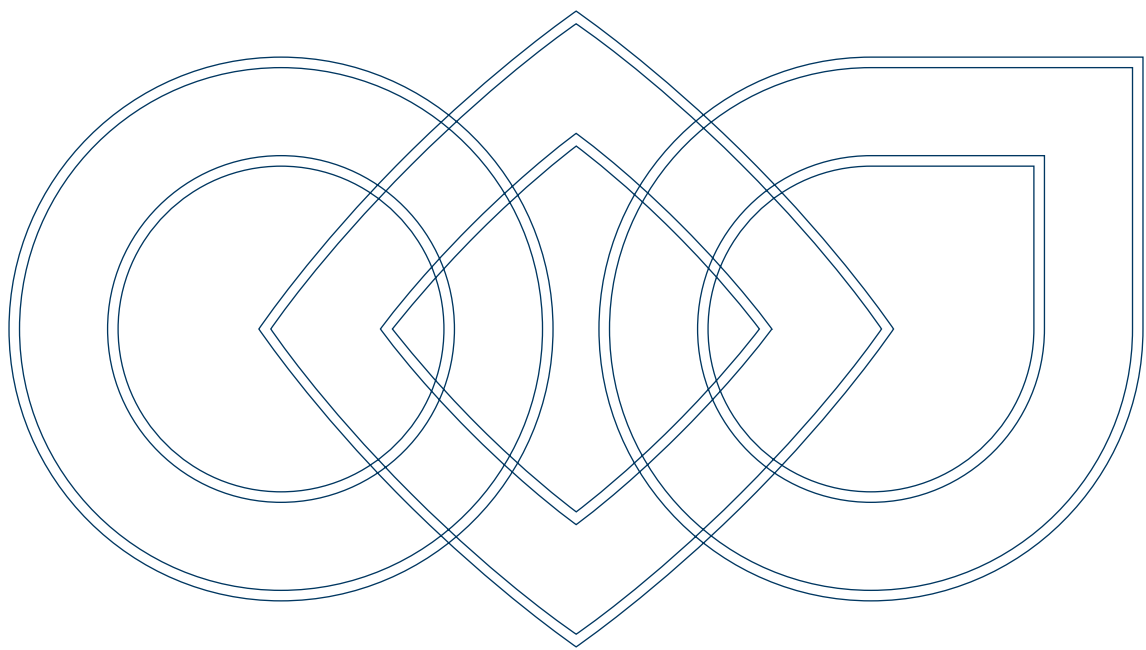

Contents

5	Advanced drive system for industrial automation
6	Machinery system configuration
7	Product range and designation of Bonfiglioli servomotors with integrated drive
8	Product designation
9	Mechanical interface
10	Mechanical tolerances
10	Shaft loads
11	Standards and directives
12	Torque-speed characteristic
21	Dimensions
22	Encoder datasheets
23	Electromechanical holding brake
23	Additional inertia feature
24	Signal connectors
25	Power and logic connector
25	DC power supply units
25	Cables
26	Servo gearhead with integrated drive
30	Bonfiglioli Worldwide Locations



Advanced drive system for industrial automation

Servo systems in industrial automation fields exploits successfully the integration of each servomotor and the relative drive.

The servomotors with integrated drives provide higher flexibility for automatic machine manufacturers in terms of space optimization and installation simplicity. Benefits of this distributed system include reduction in both installation time and cable and electrical cabinet costs. The integrated solution reduces the total unit size by more than 35% compared to classical servo drive solutions.

In addition, the servo motor with integrated drive is provided of local I/O for easy wiring of distributed signals and proper interface for bus communication.

The iBMD servo motors with integrated drive are available in four frames covering a stall torque range between 2.7 ÷ 36 Nm. The servomotors are manufactured using class F insulation materials. Each servomotor has a KTY protective temperature sensor integrated in the motor windings: operating temperature is constantly acquired and monitored by the drive to prevent all risk of damage to the motor irrespective of operating conditions.

The servomotors are equipped with single turn absolute or multi turn absolute encoders. Digital encoders with HYPERFACE® protocol are available according two operating principle, capacitive and optical, with different resolution. An optional electromechanical holding brake is available for all models as well as an internal additional flywheel mass.

The drive system can be controlled by a master controller through EtherCAT® or CANopen® interface, or it can work in stand alone mode for the application that do not require a strict synchronism among the axes.

The iBMD is provided of an internal PLC that can manage the entire machine cycle. The programmability uses ST language of IEC61131 environment with additional motion function as: interpolated mode, Gearing Function, ECAM or Capture. Thanks to its internal programmability every user can create its movement algorithm allowing complex trajectories.

The drive has 14 on board I/O's that are:

- 4 digital IN 24Vdc general purpose, configurable as: PSTOP, NSTOP, Enable, Home, Capture, Step/Direction
- 3 digital OUT 24Vdc 250mA, general purpose
- 2 digital IN 24Vdc or 1 BTB OUT
- 1 digital IN/OUT 24Vdc with configurable function
- 3 differential I/O's configurable as: Master incremental encoder or Absolute encoder input Encoder emulation output PWM IN or OUT Auxiliary RS485 I/O's extension port
- 1 Analogue IN +/-10V

The safe torque off STO (certification in progress) function is integrated in the drive. The drive software has the following integrated movement features: device profile DS402, interpolated mode, positioning, extended gearing function, Ecam, homing, capture.

Drive and motor protection are managed by the combination of different controls: I2t, overload, short circuit, overtemperature (motor, drive and encoder), overvoltage.

These servo motor drives are available with 560Vdc voltage supply and degree of protection IP65. Plugged connectors are mandatory to assure IP65 degree.

The housing is painted (RAL 9005, black).

Depending on the iBMD size, the cooling method is IC410 (free ventilation) or forced ventilation of the sole drive thanks to integrated fans.

EtherCAT®  CANopen®



Machinery system configuration

The new *i*BMD series of servomotors with integrated drive represent a successful solution for space optimization and installation simplicity in complex automatic machinery architectures.

The *i*BMD servomotors are autonomous servo axis building blocks that allow the design, integration and operation of large multi axis systems with significant reduction of the cabinet size, drastic reduction of wiring work and significant increase of flexibility and modularity.

The integration of the motor and the drive minimizes the electromagnetic compatibility

sensitivity ensuring high quality position signal thanks to the close proximity of the encoder and the interpolating drive. The *i*BMD motor drives can be supplied from a common DC bus allowing the braking energy from any drive to be intrinsically recycled on any other axis on the network.

As highlighted in the following system configuration, the *i*BMD servomotors with integrated drive are controlled by a CANOpen or EtherCAT controller, linking together groups of servomotors and stand alone drives on a single bus system.

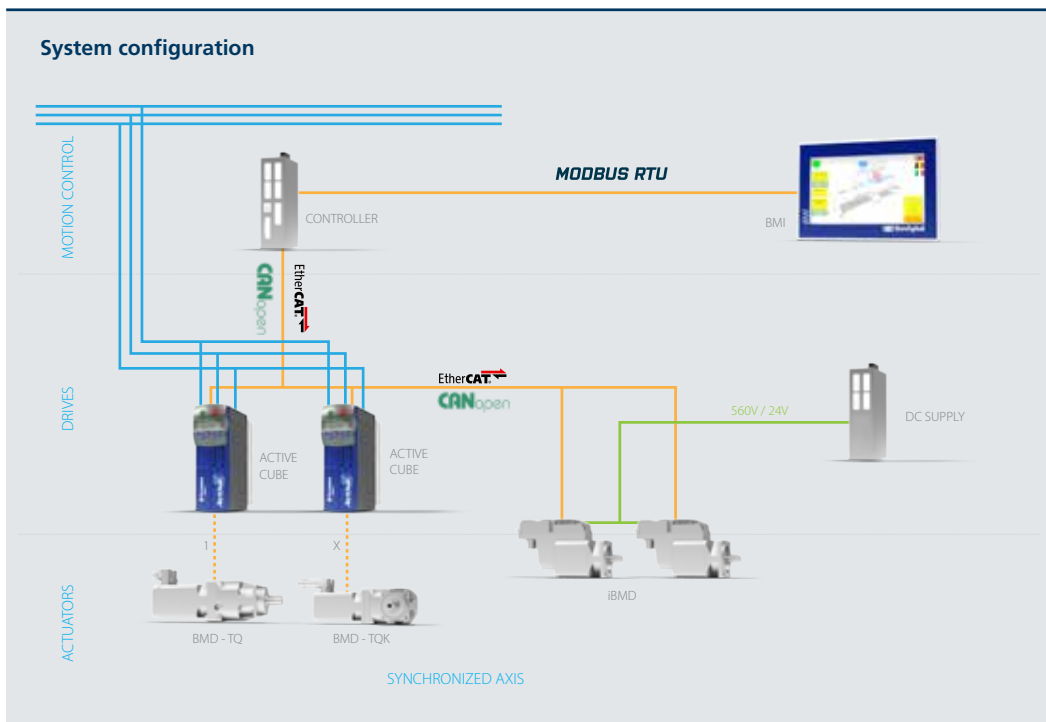

Product range and designation of Bonfiglioli servomotors with integrated drive

The Bonfiglioli servomotors with integrated drive are available in seven sizes with stall torque comprises between 2.7 - 36.

iBMD servo motors with integrated drive are technically identified by their designation. This consists of a succession of alphanumeric characters, whose positions and values conform to precise rules and define the characteristics of the product.

The complete designation provides a unique identification of the exact servomotor with integrated drive configuration.

All motor variant and drive variant fields can assume only one value at a time. These values are selected from a limited set of pre-defined values for each field in the designation.

Is mandatory to select one of the possible choices in all variants fields. The variant can be missed only where a blank is a possible choice.

Housing of iBMD servomotors is painted RAL 9005, black.

Silver dressing has to be intended for marketing and promotional purposes only.

iBMD Servomotors with integrated drive

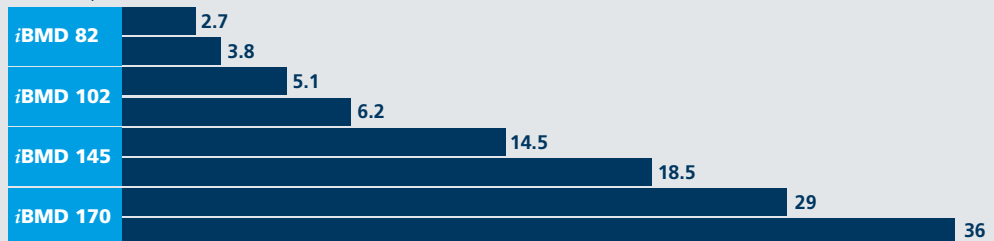
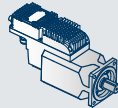

Product designation

Designation of servomotors with integrated drive

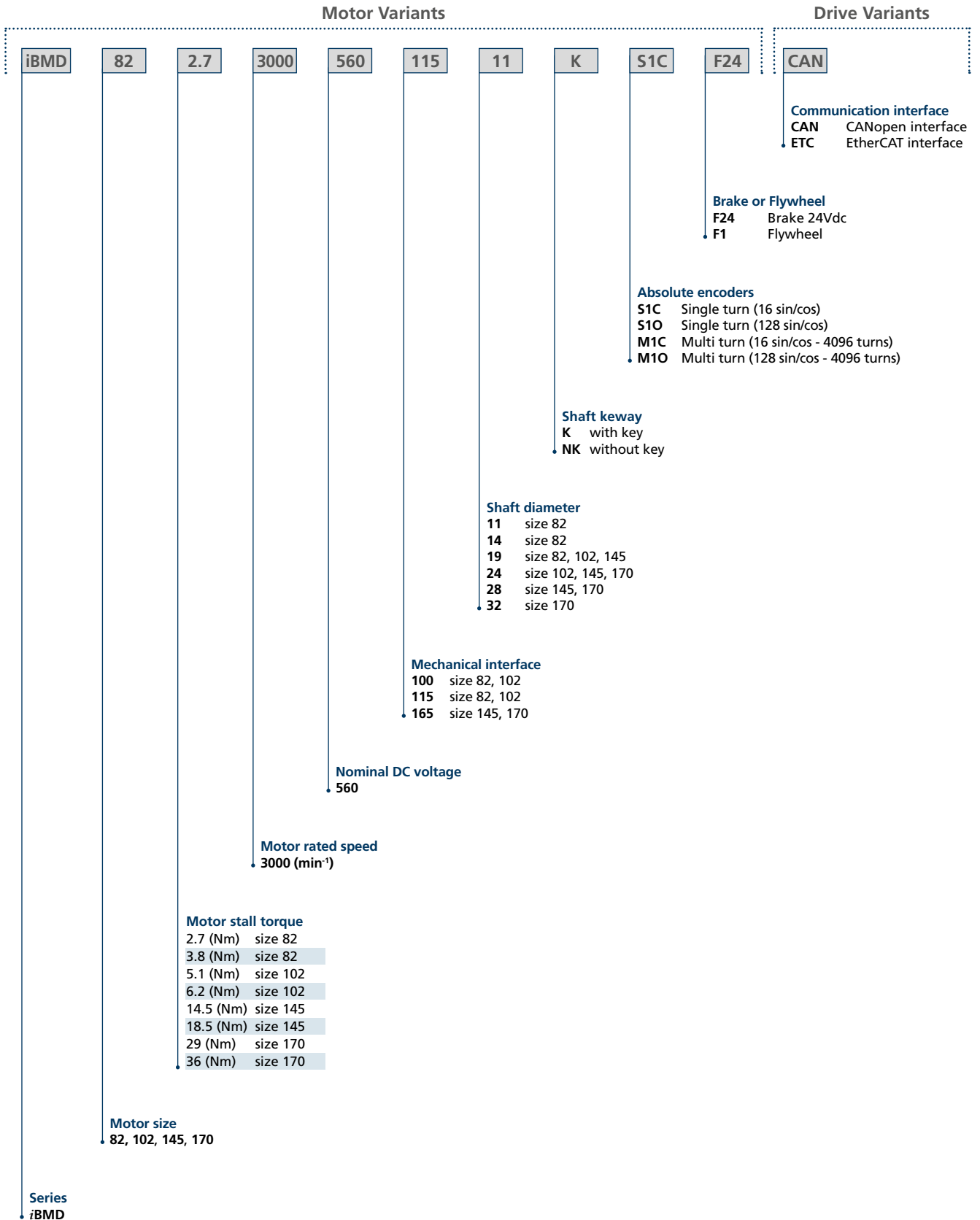

Mechanical interface

Concerning iBMD servomotors with integrated drive, fixing dimensions for coupling motor with other transmission components (gearboxes, joints, ...) is named Mechanical Interface. Therefore the Mechanical Interface is a part of the motor and includes both flange and shaft

univocally defined by its geometrical dimensions. The flanges and the shafts of iBMD are described by fixed geometrics according to standard IEC 60072-1.

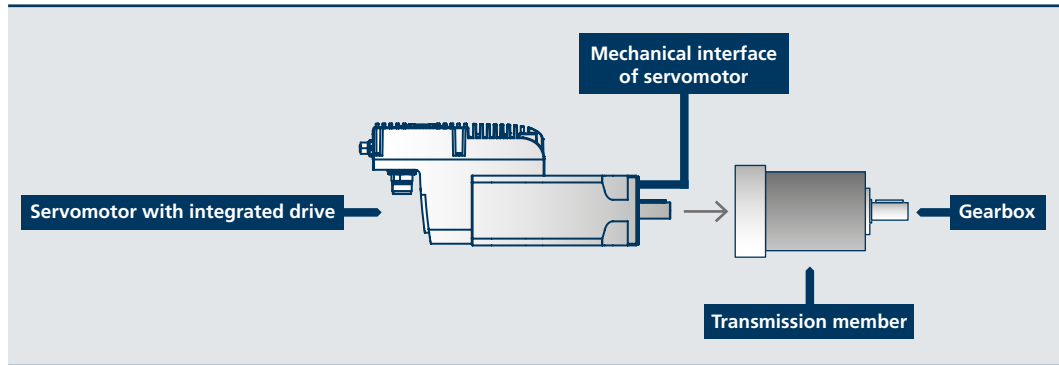

Mechanical interface: connection flange + trasmission shaft.

According to IEC 60072-1, the interface geometry is defined by quantities D, E, P, M, N, S published in the following drawing whose numerical values (mm) depend on motor size.

The basic mechanical interface of iBMD servomotor with integrated drive is defined by the dimensional sketch:

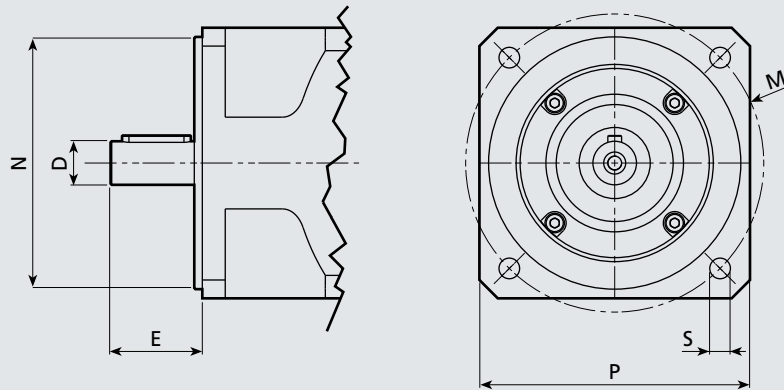

Basic Mechanical Interface

		iBMD 82		iBMD 102		iBMD 145		iBMD 170	
Shaft diameter x shaft length	DxE [mm]	11x23	14x30	19x40	24x50	19x40	24x50	28x60	32x60
Flange square	P [mm]	82	100	102	102	145	170		
Flange pitch holes diameter	M [mm]	100	115	100	115	165	165		
Diameter of the spigot	N [mm]	80	95	80	95	130	130		
Fixing holes diameters	S [mm]	6.5	9	7	9	11.5	11.5		

Mechanical tolerances

Dimensions and tolerances of shaft extension, key and flange are in accordance with IEC 60072-1. Shaft extension features an axial threaded hole in accordance with UNI 3221, DIN 332. Tolerances for the different parts are reported in the table.

Component	Dimensions	Tolerance
Shaft end	D [mm]	$\varnothing 9 - 28$
		$\varnothing 32$
Key	F [mm]	h9
Flange	N [mm]	$\varnothing < 250$

Shaft loads

The loads in the following tables have been calculated using ISO 281 calculation L_{10h} (20.000h). The loads and speeds used are considered to be constant throughout the life of the bearing. The radial load F_R is applied to the half shaft end length.

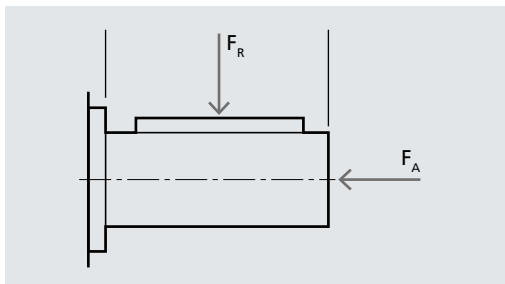

Size		Maximum radial load F_R [N]	Maximum axial load F_A [N]
82	2.7 Nm	470	94
	3.8 Nm	500	100
102	5.1 Nm	610	120
	6.2 Nm	650	130
145	14.5 Nm	1150	229
	18.5 Nm	1200	240
170	29 Nm	1400	285
	36 Nm	1500	305

Standards and directives

iBMD motors are manufactured in accordance with applicable standards and Directive listed in the following tables.

Standard

IEC 60034-1, EN 60034-1

Rotating electrical machines
Part 1: Rating and performance

IEC 60034-5, EN 60034-5

Rotating electrical machines
Part 5: Degrees of protection provided by the integral design of rotating electrical machines (IP code) - Classification

IEC 60529, EN 60529

Degrees of protection provided by enclosures (IP Code)

IEC 60034-6, EN 60034-6

Rotating electrical machines
Part 6: Methods of cooling (IC Code)

IEC 60034-14, IEC 60034-14

Rotating electrical machines
Part 14: Mechanical vibration - Measurement, evaluation and limits of vibration severity

IEC 60072-1

Dimensions and output series for rotating electrical machines - Part 1

IEC TS 60034-25

Rotating electrical machines
Part 25: Guidance for the design and performance of a.c. motors specifically designed for converter supply

IEC 61800-5-1, EN 61800-5-1

Adjustable speed electrical power drive systems
Part 5-1: Safety requirements - Electrical, thermal and energy

IEC 61800-3-1, EN 61800-3-1

Adjustable speed electrical power drive systems
Part 3: EMC requirements and specific test methods

IEC 60068-2-27

Environmental testing
Part 2-27: Tests - Test Ea and guidance: Shock

IEC 60068-2-6

Environmental testing
Part 2-6: Tests - Test Fc: Vibration (sinusoidal)

Directives

Low Voltage Directive: 2006/95/EC

Electromagnetic compatibility (EMC): 2004/108/EC

Symbols and units of measure

Symbol	U.m.	Description
n_n	[min ⁻¹]	Rated speed
M_0	[Nm]	Stall torque
M_n	[Nm]	Rated torque
M_{max}	[Nm]	Max torque
U_{pw}	[Vdc]	Rated DC voltage of power module
I_{pw}	[A _{dc}]	Rated DC current of power module
$I_{0,pw}$	[A _{dc}]	Maximum DC current of power module
P_{pw}	[kW]	Rated electrical power
P_n	[kW]	Rated mechanical power
J_m	[kgm ² x 10 ⁻⁴]	Motor moment of inertia without brake
J_{mb}	[kgm ² x 10 ⁻⁴]	Motor moment of inertia with brake
m_M	[kg]	Motor mass without brake
m_{MB}	[kg]	Motor mass with brake
J_b	[kgm ² x 10 ⁻⁴]	Brake moment of inertia
m_b	[kg]	Brake mass
M_b	[Nm]	Brake torque
P_b	[W]	Brake electrical power at 20°C
V_b	[V]	Brake DC voltage
I_b	[A]	Brake current
t_1	[ms]	Brake engaging time
t_2	[ms]	Brake release time
U_{log}	[Vdc]	Logic DC voltage
I_{log}	[Idc]	Logic DC current with digital output off
T_{amb}	[°C]	Ambient temperature range

Torque-speed characteristic

The permissible operating range of a brushless servomotor with integrated drive is limited by thermal, mechanical, and electromagnetic limits.

The thermal limit of the servomotor with integrated drive is dependent on both the thermal class of the motor insulation system (F) and the thermal limit of the drive components. To adhere to the temperature limits, the torque must be reduced as the speed increases, starting from stall torque M_0 . The maximum permissible torque is then dependent on the operation mode. The characteristic curves are assigned for continuous duty S1 and intermittent periodic duty (S3-20%, S3-50%). A transient, high overload capacity up to M_{max} is provided.

The speed range is limited by the maximum mechanical speed and the voltage limit.

The voltage limit is usually lower than the mechanical limit. The voltage limiting characteristic curve is determined by the motor nominal speed.

Therefore, the performance characteristics of a servomotor with integrated drive are described by a torque and speed operating area. The continuous duty zone is bordered by the maximum continuous torque curve up to the intersection with the voltage limit curve. Continuous duty in the area above the S1 characteristic curve is not thermally permitted for the motor. The intermittent periodic duty zone is bordered by the peak torque line and the voltage limit curve.

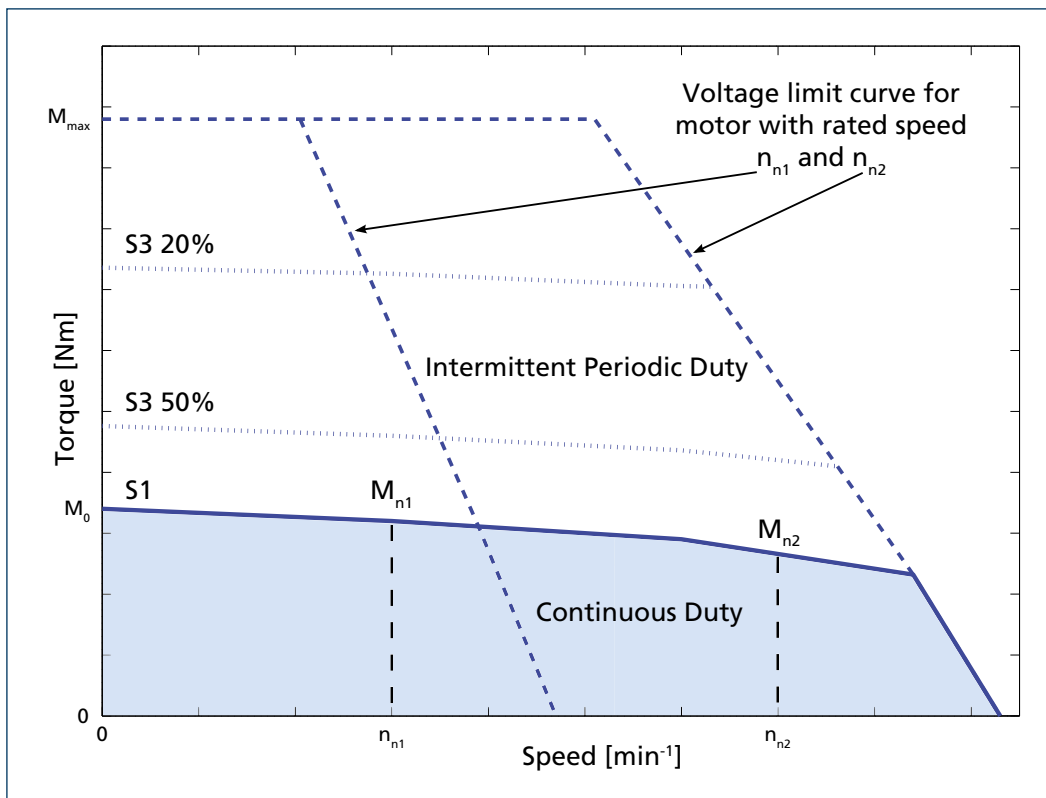

iBMD 82 • 2.7 Nm

Parameter	Symbol	Unit		
Motor rated speed	n_n	[min ⁻¹]	3000	
Standstill torque	M_0	[Nm]	2.7	
Rated Torque	M_n	[Nm]	2.4	
Max Torque	M_{max}	[Nm]	8.4	
Rated DC voltage of power module	U_{pw}	[Vdc]	560	
Rated DC current of power module	I_{pw}	[Adc]	1.7	
Maximum DC current of power module	$I_{0,pw}$	[Adc]	7.4	
Rated electrical power	P_{pw}	[kW]	0.91	
Rated mechanical power	P_n	[kW]	0.75	
Rotor inertia	without brake	J_m	[kgm ² × 10 ⁻⁴]	1.40
	with brake	J_{mb}	[kgm ² × 10 ⁻⁴]	1.58
Motor mass	without brake	m_M	[kg]	4.0
	with brake	m_{MB}	[kg]	4.7

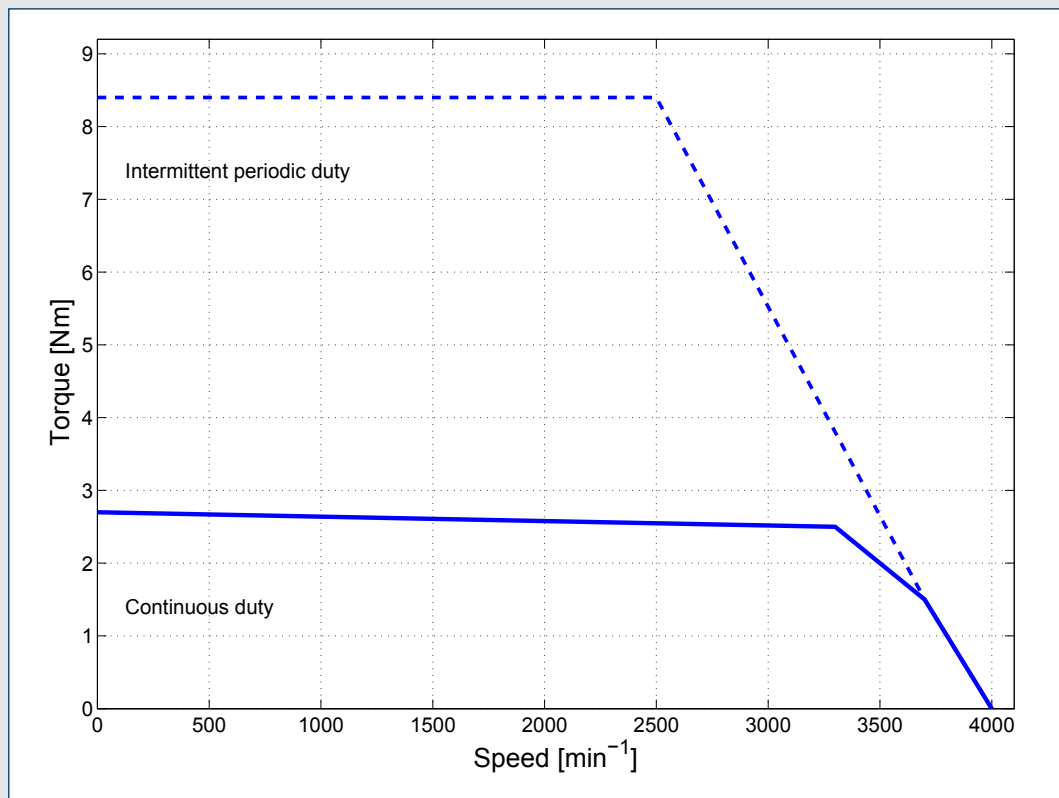

iBMD 82 • 3.8 Nm

Parameter	Symbol	Unit		
Motor rated speed	n_n	[min ⁻¹]	3000	
Standstill torque	M_0	[Nm]	3.8	
Rated Torque	M_n	[Nm]	3.3	
Max Torque	M_{max}	[Nm]	11.0	
Rated DC voltage of power module	U_{pw}	[Vdc]	560	
Rated DC current of power module	I_{pw}	[Adc]	2.1	
Maximum DC current of power module	$I_{0,pw}$	[Adc]	7.2	
Rated electrical power	P_{pw}	[kW]	1.20	
Rated mechanical power	P_n	[kW]	1.04	
Rotor inertia	without brake	J_m	[kgm ² x 10 ⁻⁴]	1.70
	with brake	J_{mb}	[kgm ² x 10 ⁻⁴]	1.88
Motor mass	without brake	m_M	[kg]	5.1
	with brake	m_{MB}	[kg]	5.7

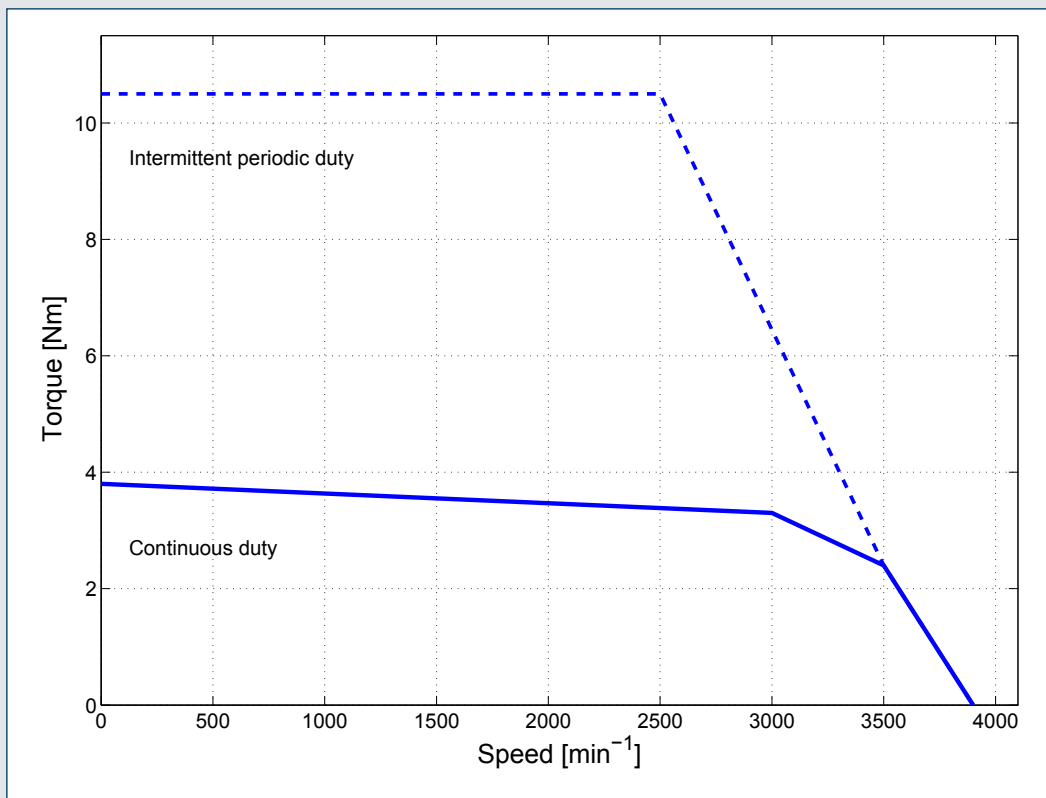

iBMD 102 • 5.1 Nm

Parameter	Symbol	Unit		
Motor rated speed	n_n	[min ⁻¹]	3000	
Standstill torque	M_0	[Nm]	5.1	
Rated Torque	M_n	[Nm]	4.5	
Max Torque	M_{max}	[Nm]	16	
Rated DC voltage of power module	U_{pw}	[Vdc]	560	
Rated DC current of power module	I_{pw}	[Adc]	2.9	
Maximum DC current of power module	$I_{0,pw}$	[Adc]	14.5	
Rated electrical power	P_{pw}	[kW]	1.60	
Rated mechanical power	P_n	[kW]	1.41	
Rotor inertia	without brake	J_m	[kgm ² x 10 ⁻⁴]	3.70
	with brake	J_{mb}	[kgm ² x 10 ⁻⁴]	4.24
Motor mass	without brake	m_M	[kg]	6.3
	with brake	m_{MB}	[kg]	7.5

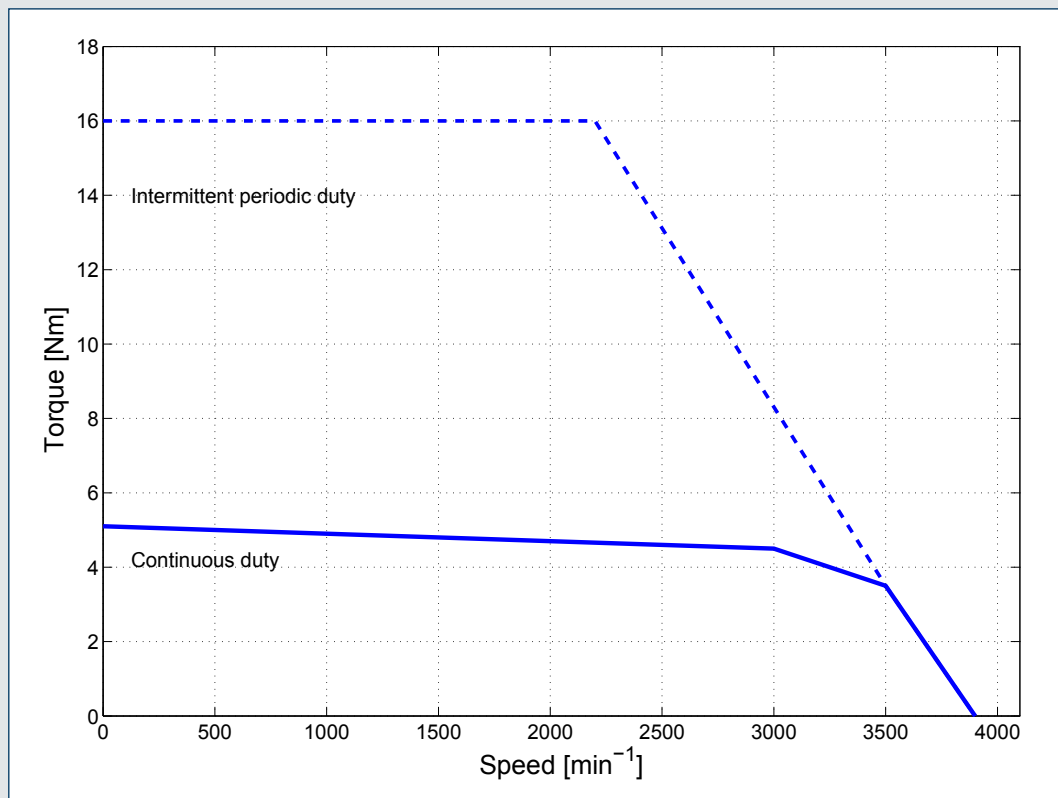

iBMD 102 • 6.2 Nm

Parameter	Symbol	Unit		
Motor rated speed	n_n	[min ⁻¹]	3000	
Standstill torque	M_0	[Nm]	6.2	
Rated Torque	M_n	[Nm]	5.5	
Max Torque	M_{max}	[Nm]	23	
Rated DC voltage of power module	U_{pw}	[Vdc]	560	
Rated DC current of power module	I_{pw}	[Adc]	3.5	
Maximum DC current of power module	$I_{0,pw}$	[Adc]	15	
Rated electrical power	P_{pw}	[kW]	1.92	
Rated mechanical power	P_n	[kW]	1.73	
Rotor inertia	without brake	J_m	[kgm ² x 10 ⁻⁴]	4.70
	with brake	J_{mb}	[kgm ² x 10 ⁻⁴]	5.30
Motor mass	without brake	m_M	[kg]	7.9
	with brake	m_{MB}	[kg]	8.9

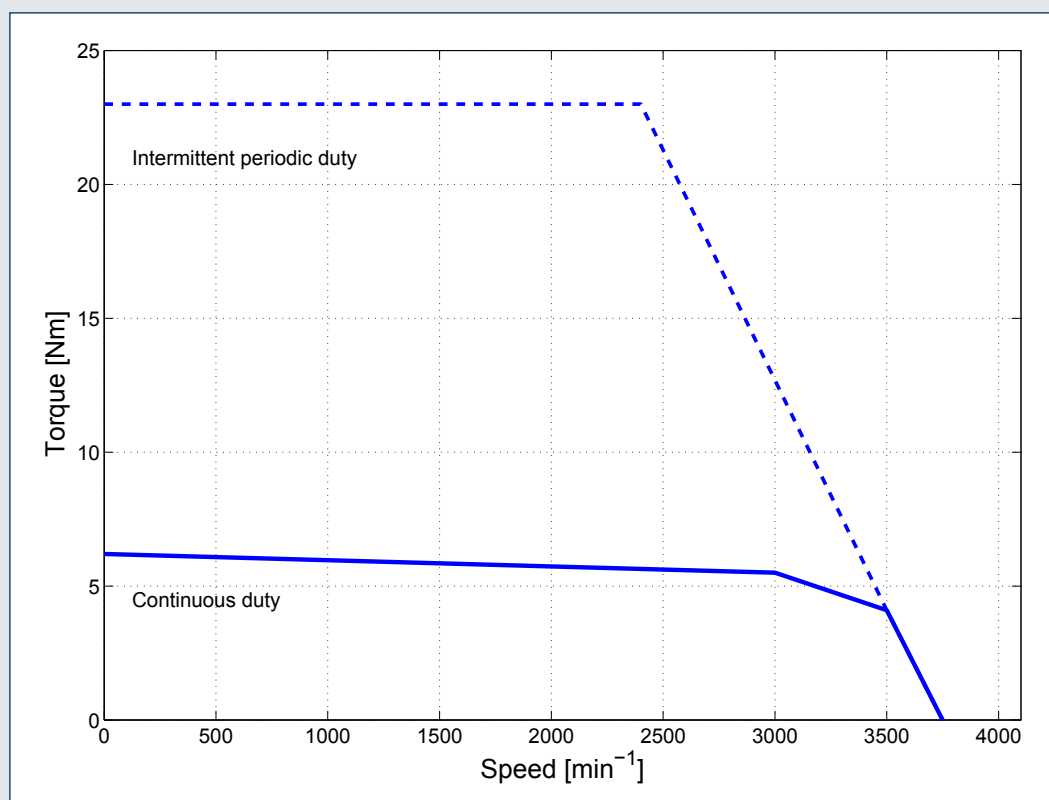

iBMD 145 • 14.5 Nm

Parameter	Symbol	Unit		
Motor rated speed	n_n	[min ⁻¹]	3000	
Standstill torque	M_0	[Nm]	14.5	
Rated Torque	M_n	[Nm]	11	
Max Torque	M_{max}	[Nm]	39	
Rated DC voltage of power module	U_{pw}	[Vdc]	560	
Rated DC current of power module	I_{pw}	[Adc]	6.9	
Maximum DC current of power module	$I_{0,pw}$	[Adc]	28.3	
Rated electrical power	P_{pw}	[kW]	3.85	
Rated mechanical power	P_n	[kW]	3.45	
Rotor inertia	without brake	J_m	[kgm ² x 10 ⁻⁴]	12.8
	with brake	J_{mb}	[kgm ² x 10 ⁻⁴]	14.5
Motor mass	without brake	m_M	[kg]	17.6
	with brake	m_{MB}	[kg]	20.2

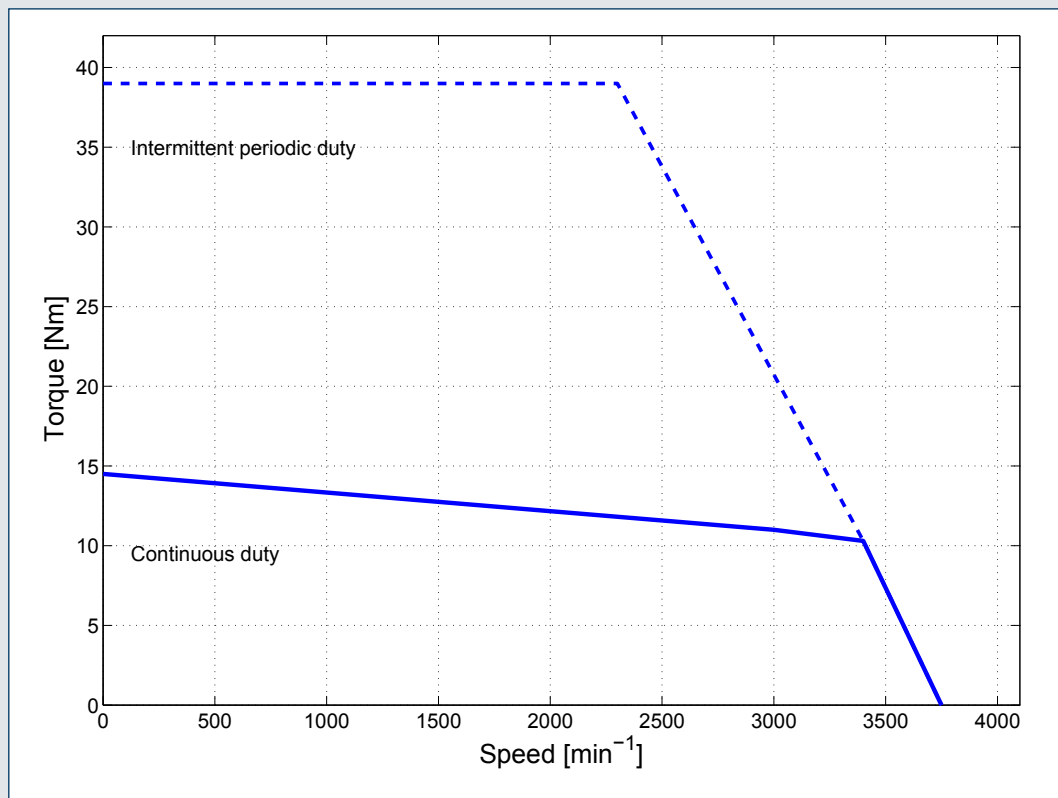

iBMD 145 • 18.5 Nm

Parameter	Symbol	Unit		
Motor rated speed	n_n	[min ⁻¹]	3000	
Standstill torque	M_0	[Nm]	18.5	
Rated Torque	M_n	[Nm]	12.5	
Max Torque	M_{max}	[Nm]	45	
Rated DC voltage of power module	U_{pw}	[Vdc]	560	
Rated DC current of power module	I_{pw}	[Adc]	7.8	
Maximum DC current of power module	$I_{0,pw}$	[Adc]	28.0	
Rated electrical power	P_{pw}	[kW]	4.33	
Rated mechanical power	P_n	[kW]	3.93	
Rotor inertia	without brake	J_m	[kgm ² x 10 ⁻⁴]	17.6
	with brake	J_{mb}	[kgm ² x 10 ⁻⁴]	19.3
Motor mass	without brake	m_M	[kg]	20.6
	with brake	m_{MB}	[kg]	23.2

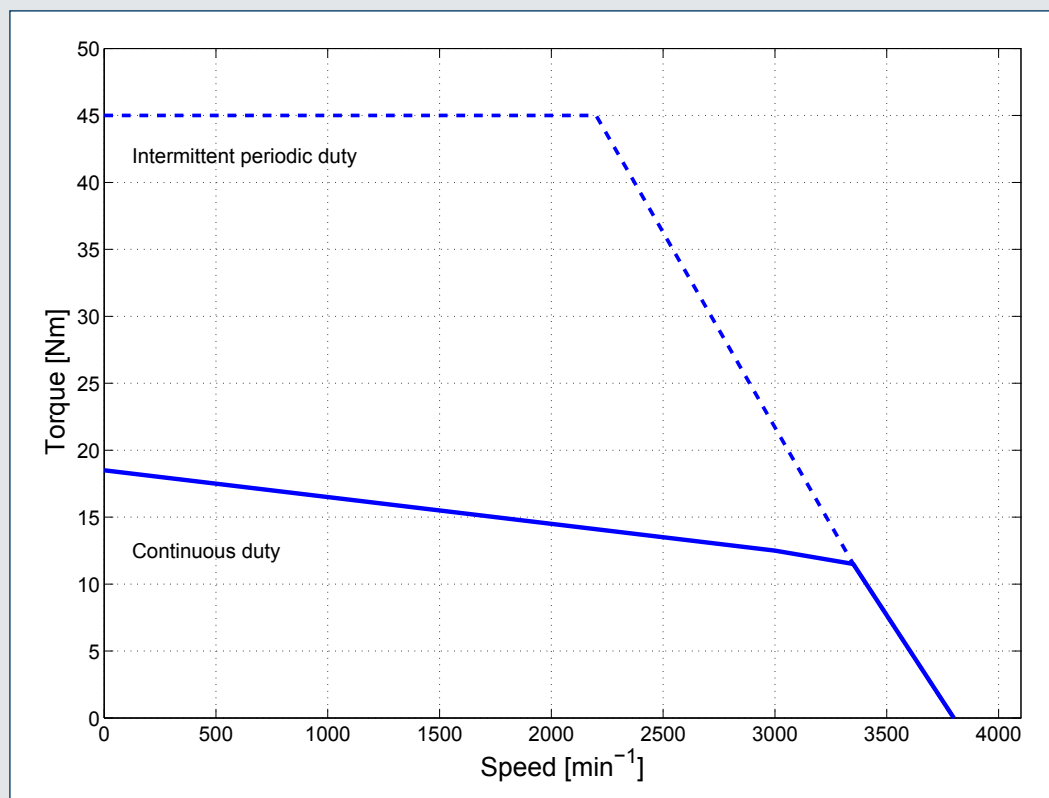

iBMD 170 • 29 Nm

Parameter	Symbol	Unit		
Motor rated speed	n_n	[min ⁻¹]	3000	
Standstill torque	M_0	[Nm]	29	
Rated Torque	M_n	[Nm]	14.7	
Max Torque	M_{max}	[Nm]	62	
Rated DC voltage of power module	U_{pw}	[Vdc]	560	
Rated DC current of power module	I_{pw}	[Adc]	9.1	
Maximum DC current of power module	$I_{0,pw}$	[Adc]	40.0	
Rated electrical power	P_{pw}	[kW]	5.05	
Rated mechanical power	P_n	[kW]	4.62	
Rotor inertia	without brake	J_m	[kgm ² × 10 ⁻⁴]	28.2
	with brake	J_{mb}	[kgm ² × 10 ⁻⁴]	33.8
Motor mass	without brake	m_M	[kg]	27.4
	with brake	m_{MB}	[kg]	31.9

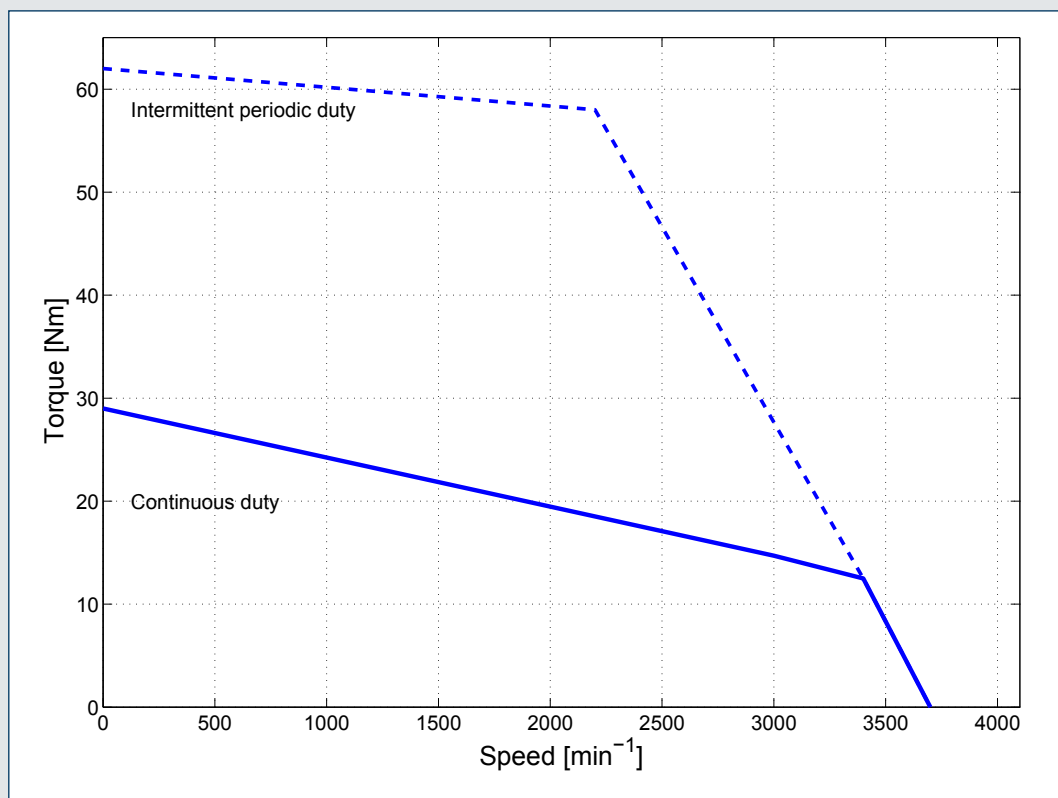

iBMD 170 • 36 Nm

Parameter	Symbol	Unit		
Motor rated speed	n_n	[min ⁻¹]	3000	
Standstill torque	M_0	[Nm]	36	
Rated Torque	M_n	[Nm]	21	
Max Torque	M_{max}	[Nm]	70	
Rated DC voltage of power module	U_{pw}	[Vdc]	560	
Rated DC current of power module	I_{pw}	[Adc]	12.8	
Maximum DC current of power module	$I_{0,pw}$	[Adc]	42.0	
Rated electrical power	P_{pw}	[kW]	7.16	
Rated mechanical power	P_n	[kW]	6.60	
Rotor inertia	without brake	J_m	[kgm ² x 10 ⁻⁴]	47.5
	with brake	J_{mb}	[kgm ² x 10 ⁻⁴]	53.1
Motor mass	without brake	m_M	[kg]	32.4
	with brake	m_{MB}	[kg]	36.9

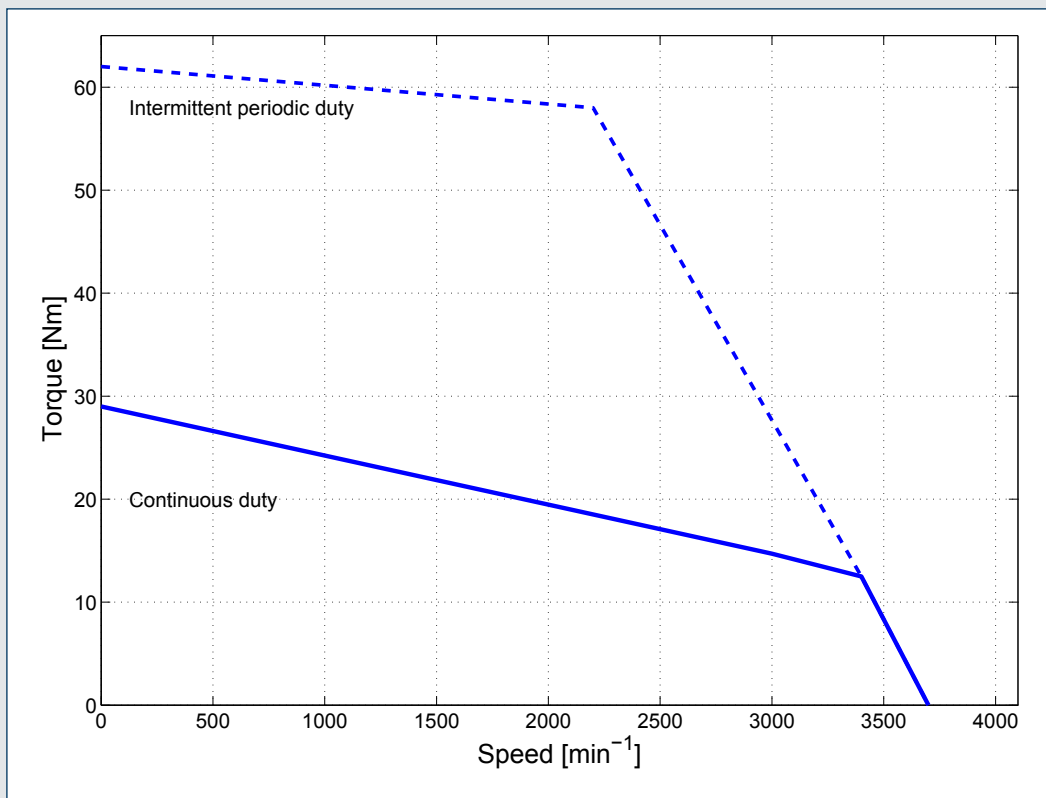

Dimensions

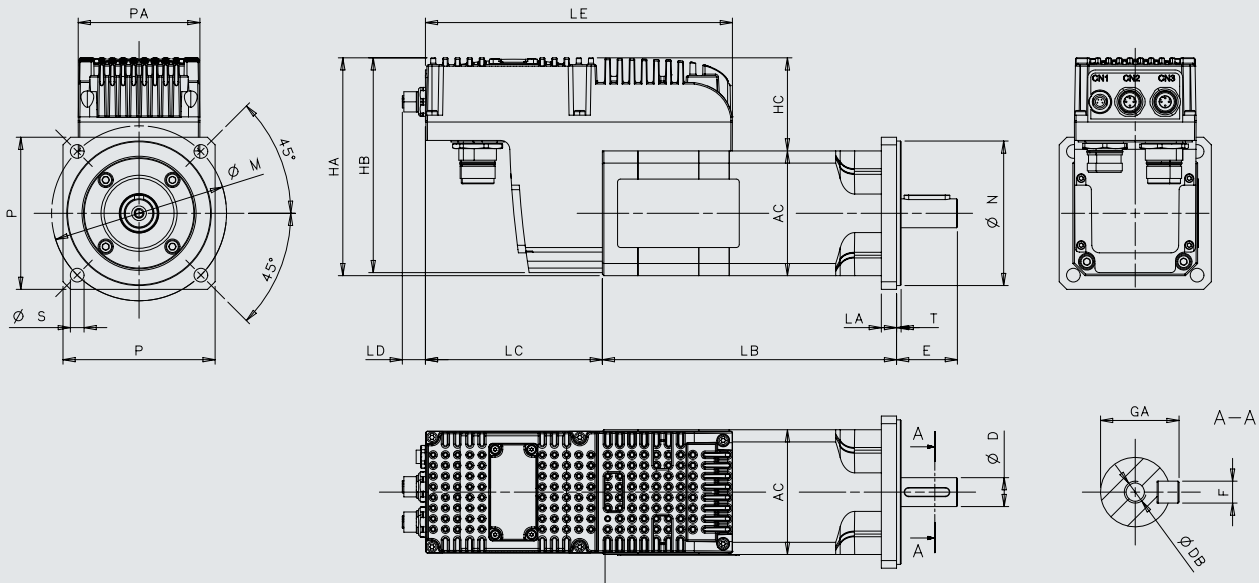

Size	Shaft				
	D	E	DB	GA ⁽¹⁾	F ⁽¹⁾
82	11	23	M4	12.5	4
	14	30	M5	16	5
	19	40	M6	21.5	6
102	19	40	M6	21.5	6
	24	50	M8	27	8
145	19	40	M6	21.5	6
	24	50	M8	27	8
	28	60	M10	31	8
170	24	50	M8	27	8
	28	60	M10	31	8
	32	60	M12	35	10

Size	Flange					
	M	N	P	S	T	LA
82	100	80	82	6.5	3	10
	115	95	100	9	3	10
102	100	80	102	7	3	10
	115	95	102	9	3	10
145	165	130	145	11.5	3.5	12
170	165	130	170	11.5	3.5	12

Size	Motor with integrated drive										
	T0	AC	PA	LB2	LB3	LC	LD	LE	HA	HB	HC
82	2.7	82	80	121	174	117	16	202	144	142	62
	3.8		80	141	194						
102	5.1	102	80	141	191	117	16	202	164	142	62
	6.2		80	168	218						
145	14.5	145	142	228	275	120	-	300	225	222	80
	18.5		142	228	310						
170	29	170	142	233	305	120	-	300	225	222	80
	36		142	286	357						

Notes:
 (1) It is available the version with motor shaft without key.
 LB₂ Standard motor length.
 LB₃ Length of standard motor with brake or flywheel.

Encoder datasheets

Bonfiglioli *iBMD* servomotor with integrated drive series is available with different feedback devices. Available feedbacks are absolute encoders, single turn or multi turn.

The optical absolute encoder uses a high precision optical disc while the capacitive absolute encoder uses the capacitive principle for position measurement.

The high resolution performed is based on a combination of absolute information, transmitted

via a serial link, and sine/cosine signals with incremental techniques according to the data interface HIPERFACE®.

Single turn absolute encoder has an absolute positional information only within one turn.

Multi turn absolute encoder is provided of extra gear wheels that account for several shaft revolution. Therefore the output is unique for each shaft position and revolution up to available revolutions.

SINGLE TURN ENCODERS

Item	S1C	S1O
Manufacturer	Sick AG	
Model	SEK37	SKS36
Type	Capacitive	Optical
Sine/Cosine periods per revolution	16	128
Position per revolution	512 (9 bits)	4096 (12 bits)
Max Speed	120000 min ⁻¹	120000 min ⁻¹
Resistance to shocks	100 g / 10 ms	100 g / 6 ms
Resistance to vibrations	50 g / 10 ... 2000 Hz	

MULTI TURN ENCODERS

Item	M1C	M1O
Manufacturer	Sick AG	
Model	SEL37	SKM36
Type	Capacitive	Optical
Sine/Cosine periods per revolution	16	128
Position per revolution	512 (9 bits)	4096 (12 bits)
Revolutions	4096 (12 bits)	4096 (12 bits)
Max Speed	120000 min ⁻¹	120000 min ⁻¹
Resistance to shocks	100 g / 10 ms	100 g / 6 ms
Resistance to vibrations	50 g / 10 ... 2000 Hz	

Electromechanical holding brake

An electromagnetic holding brake is available. The brake variant can be ordered by selecting the F24 value in the brake option field.

The electromechanical brake is for use as an holding brake with motor shaft stationary. Do not use it as a dynamic brake, except for emergencies such as main supply failure.

Data of the available brake for each motor size are summarized in the following table.

When the motor is delivered without brake, the brake fitting is not possible.

The brake coil voltage supply must be 24V DC-voltage.

The brake option is responsible of an increment of the motor length (see in page 18).

Brake leads are wired in the power connector together with motor leads.

Size	Motor stall torque	Rated brake torque 20°C M_b	Rated brake torque 100°C M_b	Brake voltage V_b	Brake current I_b	Brake power 20°C P_b	Brake inertia	Mass m_b	Engaging time t_1	Release time t_2
	Nm	Nm	Nm	Vdc	A	W	$Kgm^2 \times 10^{-4}$	kg	ms	ms
82	2.7	4.5	4	24	0.5	12	0.18	0.35	7	35
	3.8									
102	5.1	9	8		0.75	18	0.54	0.7	7	40
	6.2									
145	14.5	18	15		1.0	24	1.66	1.1	10	50
	18.5									
170	29	36	32		1.1	26	5.56	1.8	22	90
	36									

Note

t_1 Time from disconnecting the current until the rated torque is attained

t_2 Time from connecting the current until the torque decreases

Additional inertia feature

iBMD servomotor with integrated drive series is provided optionally with additional inertia. The iBMD servomotors with additional inertia have higher rotor moment of inertia in comparison with basic version.

Additional inertia is designed to be used in application with high load inertia. The increased rotor moment of inertia provides a comfortable control response due to "higher" inertial matching of the machine.

Size	Motor stall torque	Additional inertia	Additional weight
	Nm	$Kgm^2 \times 10^{-4}$	kg
82	2.7	3	0.7
	3.8		
102	5.1	7.5	1.3
	6.2		
145	14.5	36	3.6
	18.5		
170	29	70	5.5
	36		

Signal connectors

CN1 Auxiliary bus (RS232 Serial port)		
PIN NUMBER	SIGNAL	DESCRIPTION
1	TX232	Transmit Data RS232
2	RX232	Receive Data RS232
3	NC	Reserved, not connected
4	GND_COM	Ground RS232
Chassis	PE	Protection Earth

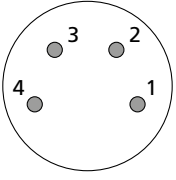

CN2,CN3 Main bus (ETC)		
PIN NUMBER	SIGNAL	DESCRIPTION
1	TX Data +	Transmit Data +
2	RX Data +	Receive Data +
3	TX Data -	Transmit Data -
4	RX Data -	Receive Data -
Chassis	PE	Protection Earth

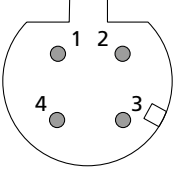

CN2,CN3 Main bus (CAN)		
PIN NUMBER	SIGNAL	DESCRIPTION
1	SHIELD	Shield
2	NC	Reserved, not connected
3	GND_CAN	Ground CAN
4	CAN-H	CAN High
5	CAN-L	CAN Low
Chassis	PE	Protection Earth

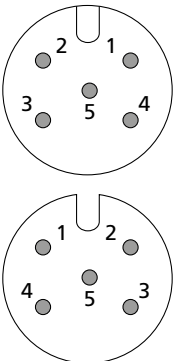

CN4 Input/Output		
PIN NUMBER	SIGNAL	DESCRIPTION
1	IN/OUT1 -	Differential digital Input/Output 1 (-)
2	IN/OUT2 -	Differential digital Input/Output 2 (-)
3	AN_IN -	Analog Input (-)
4	AN_IN +	Analog Input (+)
5	IN/OUT2 +	Differential digital Input/Output 2 (+)
6	GND_5V	Ground of +5V
7	+5V	+5V Supply (max 150mA) for auxiliary encoder
8	IN8	Digital Input 8
9	OUT5	Output 5
10	IN/OUT3	Digital Input/Output 3
11	IN7	Digital Input 7
12	IN/OUT0 -	Differential digital Input/Output 0 (-)
13	IN/OUT0 +	Differential digital Input/Output 0 (+)
14	IN/OUT1 +	Differential digital Input/Output 1 (+)
15	IN4	Digital Input 4
16	OUT4	Output 4
17	OUT6	Output 6
18	IN6	Digital Input 6
19	IN5	Digital Input 5 (the function Simulated GND is available)
Chassis		

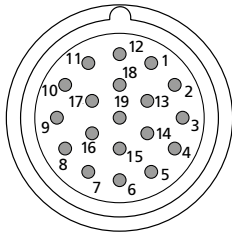

Power and logic connector

CN5 DC Power and Logic supply, /STO , IN9			
PIN NUMBER	SIGNAL	DESCRIPTION	
1	HV -	DC Power supply (negative pole)	
3	NC	Not connected	
4	HV +	DC Power supply (positive pole)	
T	PE	Protection Earth	
A	/STO	Safe Torque Off Input (this is an active-low logic signal)	
B	GND	Ground Logic supply	
C	IN9	Digital Input 9	
D	+24 V	+24Vdc Logic supply	
Chassis			

DC power supply units

The iBMD servomotor with integrated drive requires 24V DC for logic supply, and 560V DC for power supply. DC power supply units with online diagnostics and parametrizations via serial connection and PC interface are available with ratings 20A and 40A. Overall dimensions are H352.5xW82.4xD270.6 (5.8kg).

CODE ORDER	DESIGNATION	DESCRIPTION	
710210052	iBMD DC 20A	DC supply 20A 10kW	
710210053	iBMD DC 40A	DC supply 40A 20kW	

Cables

Pre-assembled cables for plug-in installation are available according to the required length. The available cables for iBMD servomotor with

integrated drive are reported in the following table. Connectors and caps are mandatory to assure degree of protection IP65.

CODE ORDER	DESIGNATION	DESCRIPTION
612580295	CAN M-D 03	CAN Cable for master to drive - Length 3m
612580296	CAN M-D 05	CAN Cable for master to drive - Length 5m
612580297	CAN M-D 10	CAN Cable for master to drive - Length 10m
612580298	CAN D-D 01	CAN Cable for drive to drive - Length 1m
612580299	CAN D-D 03	CAN Cable for drive to drive - Length 3m
612580300	CAN D-D 05	CAN Cable for drive to drive - Length 5m
612580301	CAN D-D 10	CAN Cable for drive to drive - Length 10m
612580289	iBMD Power 03	CN5 - Power cable - Length 3m
612580290	iBMD Power 05	CN5 - Power cable - Length 5m
612580291	iBMD Power 10	CN5 - Power cable - Length 10m
612580292	IN-OUT 03	CN4 - I/O cable - Length 3m
612580293	IN-OUT 05	CN4 - I/O cable - Length 5m
612580294	IN-OUT 10	CN4 - I/O cable - Length 10m
612580309	RS232 01	CN1 - RS232 cable - Length 1m
612580302	ETC M-D 03	ETC Cable for master to drive - Length 3m
612580303	ETC M-D 05	ETC Cable for master to drive - Length 5m
612580304	ETC M-D 10	ETC Cable for master to drive - Length 10m
612580305	ETC D-D 01	ETC Cable for drive to drive - Length 1m
612580306	ETC D-D 03	ETC Cable for drive to drive - Length 3m
612580307	ETC D-D 05	ETC Cable for drive to drive - Length 5m
612580308	ETC D-D 10	ETC Cable for drive to drive - Length 10m
718409114	iBMD CN1	CN1 Plastic cap
718409115	iBMD CN2	CN2 Plastic cap
718409116	iBMD CN3	CN3 Plastic cap
718409117	iBMD I-O	CN4 Dust cover cap
718409118	iBMD I-O IP65	CN4 IP65 cap
718409119	iBMD POWER	CN5 Dust cover cap

Servo gearhead with integrated drive

Motion application requires the use of precision planetary gearboxes to adapt speeds and torques, while ensuring the precision demanded by the application.

Bonfiglioli Riduttori has chosen to use planetary gearboxes with the iBMD range of servo motor with integrated drive.

Bonfiglioli precision planetary gearboxes (PPG) match with iBMD servomotor with integrated drive and provide industrial motion control equipment with torque multiplication and proper inertial matching.

These gearheads combined with powerful drive electronics are designed for servo applications requiring highest standards in terms of dynamics, precision, robustness, durability, and long trouble-free operation.

Low backlash at a competitive price.

The LC Series of planetary gearboxes is characterized by low backlash, silent running and easy motor coupling.

High precision for excellent results.

The MP Series of low backlash planetary gearboxes is characterized by a wide range of mounting configurations, silent running, and superbly easy motor coupling.

Maximum precision for highly dynamic applications.

The TQ Series of precision planetary gearboxes is designed to deliver the highest level of transmission precision. Low backlash combined with a high torsional stiffness guarantees a very performing product, for in high dynamic and reversing applications. The technical design of this gearbox also allows high axial and radial loads on the output shaft.

iBMD Servomotor / LC series Precision Planetary Gearbox combination

Ratios from 3:1 to 70:1

Type	Motor stall torque [Nm]	Ratios										Motor inertia kgm ² x 10 ⁻³	
		3:1	4:1	5:1	7:1	10:1	16:1	20:1	25:1	40:1	50:1		70:1
iBMD 82	2.7	LC 050 LC 070	LC 070 LC 090	LC 070 LC 090	LC 070 LC 090	LC 090 LC 120	LC 120	LC 120	LC 120 LC 155	LC 155	LC 155		0.14
	3.8	LC 070 LC 090	LC 070 LC 090	LC 070 LC 090	LC 070 LC 090	LC 120	LC 120	LC 120	LC 120 LC 155	LC 155	LC 155		0.17
iBMD 102	5.1	LC 090	LC 090	LC 090 LC 120	LC 120	LC 120 LC 155	LC 155	LC 155	LC 155	LC 155			0.34
	6.2	LC 090	LC 090	LC 090 LC 120	LC 120	LC 155	LC 155	LC 155	LC 155				0.47
iBMD 145	14.5	LC 120	LC 120	LC 120 LC 155	LC 155	LC 155	LC 155						1.4
	18.5	LC 120	LC 120	LC 120 LC 155	LC 155	LC 155							1.76
iBMD 170	29	LC 155	LC 155	LC 155	LC 155								2.9
	36	LC 155	LC 155	LC 155									4.8

Distribution of gearbox output torque [Nm]

	3	4	5	7	10	16	20	25	40	50	70
LC 050	10	12	12	12	-	12	12	12	-	-	-
LC 070	18	25	25	25	18	25	25	25	25	25	25
LC 090	37	43	43	43	37	43	43	43	43	43	43
LC 120	95	110	110	110	95	110	110	110	110	110	110
LC 155	250	300	300	300	250	300	300	300	300	300	300

Notes:

Input speed lower than 3000 min⁻¹.

Safety factor 1 < S ≤ 4.

For any additional technical information about gearboxes selection see relevant catalogues.

iBMD Servomotor / MP series Precision Planetary Gearbox combination

Ratios from 3:1 to 70:1

Type	Motor stall torque [Nm]	Ratios												Motor inertia kgm ² x 10 ⁻³
		3:1	4:1	5:1	6:1	7:1	10:1	16:1	20:1	25:1	40:1	50:1	70:1	
iBMD 82	2.7	MP 053 MP 060	MP 053 MP 060	MP 060 MP 080	MP 060 MP 080	MP 060 MP 080	MP 080 MP 105	MP 080 MP 105	MP 080 MP 105	MP 105	MP 105 MP 130	MP 105 MP 130	MP 130 MP 160	0.14
	3.8	MP 060	MP 060	MP 060 MP 080	MP 060 MP 080	MP 060 MP 080	MP 080 MP 105	MP 080 MP 105	MP 080 MP 105	MP 105	MP 105 MP 130	MP 105 MP 130	MP 130 MP 160	0.17
iBMD 102	5.1	MP 080	MP 080	MP 080	MP 080 MP 105	MP 080 MP 105	MP 105	MP 105	MP 105 MP 130	MP 130	MP 130 MP 160	MP 130 MP 160	MP 160	0.34
	6.2	MP 080	MP 080	MP 080	MP 105	MP 105	MP 105	MP 105	MP 105 MP 130	MP 130	MP 130 MP 160	MP 130 MP 160	MP 160	0.47
iBMD 145	14.5	MP 105	MP 105	MP 105	MP 105 MP 130	MP 105 MP 130	MP 130 MP 160	MP 130 MP 160 MP 190	MP 130 MP 160 MP 190	MP 160	MP 160 MP 190	MP 190		1.4
	18.5	MP 105	MP 105	MP 105	MP 105 MP 130	MP 130	MP 160	MP 130 MP 160 MP 190	MP 130 MP 160 MP 190	MP 160	MP 160 MP 190	MP 190		1.76
iBMD 170	29	MP 105	MP 105 MP 130	MP 130	MP 130	MP 130	MP 160	MP 160 MP 190	MP 160 MP 190	MP 190				2.9
	36	MP130	MP130	MP130	MP130 MP160	MP130 MP160	MP 190	MP 160 MP 190	MP 160 MP 190	MP 190				4.8

Distribution of gearbox output torque [Nm]												
	3	4	5	6	7	10	16	20	25	40	50	70
MP 053	12	15	15	15	15	-	20	20	20	-	-	-
MP 060	18	25	25	25	25	18	30	30	30	30	30	30
MP 080	40	50	50	50	50	40	70	70	70	70	70	70
MP 105	100	140	140	140	140	100	170	170	170	170	170	170
MP 130	215	380	380	380	380	215	450	450	450	450	450	450
MP 160	350	500	500	500	500	350	700	700	700	700	700	700
MP 190	500	700	700	700	700	500	1000	1000	1000	1000	1000	1000

Notes:

Input speed lower than 3000 min⁻¹.

Safety factor 1 < S ≤ 4.

For any additional technical information about gearboxes selection see relevant catalogues.

iBMD Servomotor / TQ series Precision Planetary Gearbox combination

Ratios from 3:1 to 70:1

Type	Motor stall torque [Nm]	Ratios										Motor inertia kgm ² x 10 ⁻³	
		3:1	4:1	5:1	7:1	10:1	16:1	20:1	25:1	40:1	50:1		70:1
iBMD 82	2.7	TQ 070	TQ 070	TQ 070	TQ 070	TQ 090	TQ 070	TQ 070	TQ 090	TQ 090	TQ 090		0.14
	3.8	TQ 070	TQ 070	TQ 070	TQ 070	TQ 090	TQ 090	TQ 090	TQ 090	TQ 090	TQ 090		0.17
iBMD 102	5.1	TQ 070	TQ 090	TQ 090 TQ 090	TQ 070 TQ 090	TQ 090	TQ 090	TQ 090	TQ 090	TQ 090	TQ 090		0.34
	6.2	TQ 070	TQ 090	TQ 090 TQ 090	TQ 070 TQ 090	TQ 090	TQ 090	TQ 130	TQ 130	TQ 130			0.47
iBMD 145	14.5	TQ 090	TQ 090	TQ 090	TQ 090 TQ130	TQ130	TQ 160	TQ 160	TQ 160	TQ 160			1.4
	18.5	TQ 090	TQ 090	TQ 090	TQ 090 TQ130	TQ130	TQ 160	TQ 160	TQ 160				1.76
iBMD 170	29	TQ 090 TQ 130	TQ 090 TQ 130	TQ 090 TQ 130	TQ130	TQ 160	TQ 160	TQ 160					2.9
	36	TQ130	TQ130	TQ130	TQ130	TQ160	TQ160						4.8

Distribution of gearbox output torque [Nm]

	3	4	5	7	10	16	20	25	40	50	70
TQ 060	21	30	30	25	20	30	30	30	30	30	25
TQ 070	45	70	70	60	40	70	70	70	70	70	60
TQ 090	130	200	180	160	110	200	180	180	200	180	160
TQ 130	260	400	400	360	280	400	400	400	400	400	360
TQ 160	530	800	800	750	550	800	800	800	800	800	750

Notes:

Input speed lower than 3000 min⁻¹.

Safety factor 1 < S ≤ 4.

For any additional technical information about gearboxes selection see relevant catalogues.

Bonfiglioli worldwide presence

Bonfiglioli is located in regions and countries around the world that enable us to provide faster sales and service to customers.
We are around the world, and around the corner.

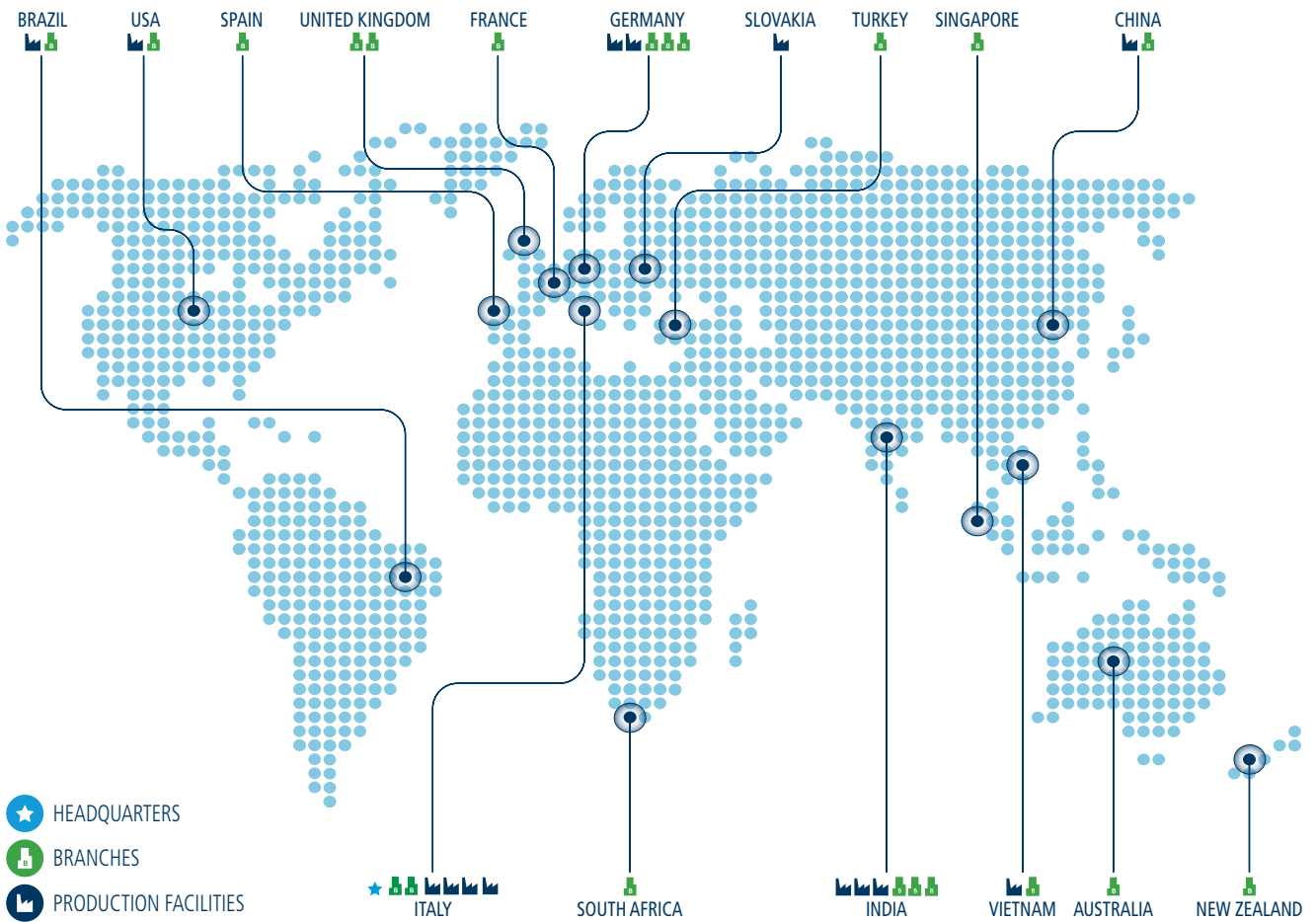

LOCAL SUPPORT
 Sales, Customer Service,
 Warranty, Tech support,
 Spare parts



**21 BRANCH OFFICES
 IN 15 COUNTRIES**



**WORLDWIDE
 DISTRIBUTION
 NETWORK**

Bonfiglioli worldwide locations

Australia

www.bonfiglioli.com.au
2, Cox Place Glendenning NSW 2761
Locked Bag 1000 Plumpton NSW 2761
Tel. + 61 2 8811 8000

Brazil

www.bonfigliolidobrasil.com.br
Travessa Cláudio Armando 171
Bloco 3 - CEP 09861-730 - Bairro Assunção
São Bernardo do Campo - São Paulo
Tel. +55 11 4344 2322

China

www.bonfiglioli.cn
Bonfiglioli Drives (Shanghai) Co., Ltd.
#68, Hui-Lian Road, QingPu District,
201707 Shanghai
Tel. +86 21 6700 2000

France

www.bonfiglioli.fr
14 Rue Eugène Pottier
Zone Industrielle de Moimont II - 95670 Marly la Ville
Tel. +33 1 34474510

Germany

www.bonfiglioli.de
Sperberweg 12 - 41468 Neuss
Tel. +49 0 2131 2988 0

Industrial

Europark Fichtenhain B6 - 47807 Krefeld
Tel. +49 0 2151 8396 0

O&K Antriebstechnik

Ruhrallee 8-12 - 45525 Hattingen
Tel. +49 0 2324 2050 1

India

www.bonfiglioli.in
Mobile, Wind
Bonfiglioli Transmissions Pvt. Ltd.
Plot No. AC7-AC11, SIDCO Industrial Estate,
Thirumudivakkam - 600 044 Chennai
Tel. +91 44 2478 1035

Industrial

Survey No. 528, Porambakkam High Road,
Mannur Village, Sriperambudur Taluk - 602 105 Chennai
Tel. +91 44 6710 3800
Plot No. A-95, Phase IV, MIDC Chakan, Village Nighoje
Pune, Maharashtra - 410 501

Italy

www.bonfiglioli.it
Headquarters
Bonfiglioli Riduttori S.p.A.
Via Giovanni XXIII, 7/A
Lippo di Calderara di Reno - 40012 Bologna
Tel. +39 051 647 3111

Mobile, Wind

Via Enrico Mattei, 12 Z.I. Villa Selva - 47100 Forlì
Tel. +39 0543 789111

Industrial

Via Bazzane, 33/A - 40012 Calderara di Reno
Tel. +39 051 6473111
Via Trinità, 1 - 41058 Vignola
Tel. +39 059 768511
Via Sandro Pertini lotto 7b - 20080 Carpiano
Tel. +39 02 985081

Bonfiglioli Mechatronic Research

Via F. Zeni 8 - 38068 Rovereto
Tel. +39 0464 443435/36

New Zealand

www.bonfiglioli.co.nz
88 Hastie Avenue, Mangere Bridge, 2022 Auckland
PO Box 11795, Ellerslie
Tel. +64 09 634 6441

Singapore

www.bonfiglioli.com
24 Pioneer Crescent #02-08
West Park Bizcentral - Singapore, 628557
Tel. +65 6268 9869

Slovakia

www.bonfiglioli.com
Robotnícka 2129
Považská Bystrica, 01701 Slovakia
Tel. +421 42 430 75 64

South Africa

www.bonfiglioli.co.za
55 Galaxy Avenue, Linbro Business Park - Sandton
Tel. +27 11 608 2030

Spain

www.tecnotrans.bonfiglioli.com
Tecnotrans Bonfiglioli S.A.
Pol. Ind. Zona Franca, Sector C, Calle F, nº 6
08040 Barcelona
Tel. +34 93 447 84 00

Turkey

www.bonfiglioli.com.tr
Atatürk Organize Sanayi Bölgesi, 10007 Sk. No. 30
Atatürk Organize Sanayi Bölgesi, 35620 Çiğli - İzmir
Tel. +90 0 232 328 22 77

United Kingdom

www.bonfiglioli.co.uk

Industrial

Unit 7, Colemeadow Road
North Moons Moat - Redditch, Worcestershire B98 9PB
Tel. +44 1527 65022

Mobile, Wind

3 - 7 Grosvenor Grange, Woolston
Warrington - Cheshire WA1 4SF
Tel. +44 1925 852667

USA

www.bonfiglioliusa.com
3541 Hargrave Drive
Hebron, Kentucky 41048
Tel. +1 859 334 3333

Vietnam

www.bonfiglioli.vn
Lot C-9D-CN My Phuoc Industrial Park 3
Ben Cat - Binh Duong Province
Tel. +84 650 3577411



We have a relentless commitment to excellence, innovation and sustainability. Our team creates, distributes and services world-class power transmission and drive solutions to keep the world in motion.



HEADQUARTERS

Bonfiglioli Riduttori S.p.A.
Via Giovanni XXIII, 7/A
40012 Lippo di Calderara di Reno
Bologna (Italy)
tel: +39 051 647 3111
fax: +39 051 647 3126
bonfiglioli@bonfiglioli.com
www.bonfiglioli.com