



# Bonfiglioli

## Vectron

---

# Agile

Advanced Standard Drive



# Bonfiglioli

power, control and green solutions

# Power, control and green solutions



## Bonfiglioli, one name for a large international group.

---

It was back in 1956 that Clementino Bonfiglioli established in Bologna, Italy, the company that still bears his name. Now, some fifty years later, the same enthusiasm and dedication is driving Bonfiglioli to become the world's top name in power transmission and control solutions. Through directly controlled subsidiaries and production plants around the world, Bonfiglioli designs, manufactures and distributes a complete range of gearmotors, drive systems and planetary gearboxes, and boasts the most integrated offering on the market today.

Now, to emphasise its commitment to health, safety and environmental sustainability, Bonfiglioli is adding the term "green" to the description of its offering.

This commitment can be seen too in the Group's new trademark, made up of three shapes and colours identifying Bonfiglioli's three main business areas - Power, Control & Green Solutions and symbolising a set of values that includes openness and respect for other cultures.

In a market in which excellent product quality alone is no longer sufficient, Bonfiglioli also provides experience, know-how, an extensive sales network, excellent pre-sales and after-sales service and modern communication tools and systems to create high level solutions for industry, mobile machinery and renewable energy.

# Bonfiglioli solutions

wind



industrial

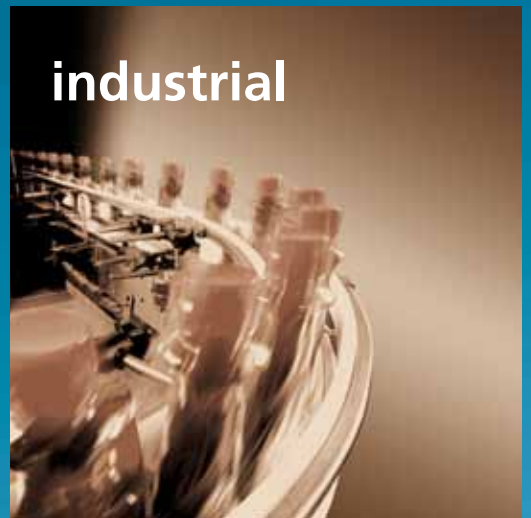

mobile

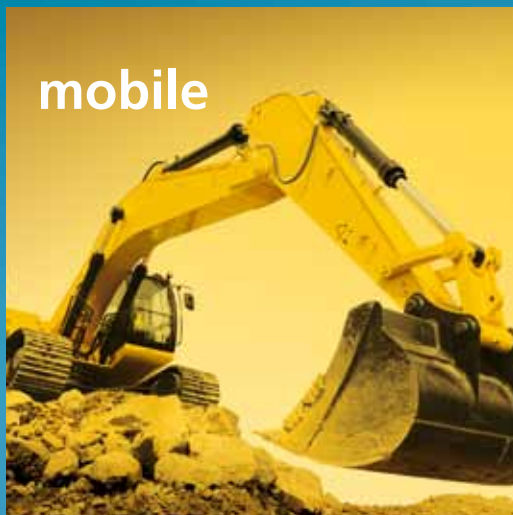

photovoltaic



## Innovative solutions for industrial field.

Bonfiglioli Riduttori today is one of the top brands in the power transmission industry. The company's success is the result of a business strategy that relies on three fundamental factors: know-how, innovation and quality. The complete range of Bonfiglioli brand gearmotors offers excellent technical characteristics and guarantees the highest performance. Substantial investment and technical expertise have enabled the company to achieve an annual production output of 1600000 units using completely automated processes.

Certification of the company's Quality System by DNV and TÜV is proof of the high quality standards achieved. With the acquisition of the Vectron brand, Bonfiglioli is now established as leader of the industrial automation sector.

Bonfiglioli Vectron delivers products and services for completely integrated inverter solutions. These solutions complement Bonfiglioli's power transmission and control offering to the industrial sector.

Since 1976, Bonfiglioli Trasmital's know-how in the power transmission industry has focused on special applications offering 100% reliability in the manufacturing of gearmotors for mobile machinery.

This includes the full range of slew and wheel drive applications and gearboxes for wind turbine pitch and yaw drive systems.

Today Bonfiglioli Trasmital stands at the forefront of the industry as a key partner to top manufacturers worldwide.



# Advanced Standard Drive



## Advanced technologies for all industrial fields.

The new Agile Series of inverter drives from Bonfiglioli sets new standards in technology for a broad range of users. Agile drives are particularly suited to the food & beverage, textile, wood, packaging and ceramic industries, where they can be used with a variety of medium complex automation processes.

Agile inverter drives implement a sensorless vector control algorithm that offers excellent performance in speed and torque control. A wide range of built-in functions deliver significant benefits to users seeking safety, energy savings, diagnostics, reliability and local intelligence.

The innovative user-friendliness of these drives is evident from the word 'go'. Even inexperienced users will find installation and start-up quick and easy.

Agile inverter drives are designed for reliability at component, machine and process levels. Software functions have been specially developed to inform users of the ideal time to perform maintenance in order to ensure continuous service from the plant.

Transparent control is ensured by Agile drives' ability to accurately diagnose themselves and surrounding components in order to avoid faults and failures in the system.

Reliable and generous, Agile drives also boast special functions designed to reduce programming costs. These functions facilitate the selection and setting of software parameters and provide a speedy and intuitive man-machine interface.

The advanced energy saving functions, adaptability and robustness of Agile inverter drives reduces impact on the environment, too.

Integrated PLC functions allow Agile drives to achieve a practical level of autonomy. The CPU not only controls the motor, but also provides the user with a number of programmable logic functions that can be used to complement or replace PLC's and process controllers.



## Overview

Agile inverter drives are designed to control asynchronous induction motors and permanent magnet synchronous servomotors. With their sleek, compact cases, Agile drives have been specially developed for maximum functional integration. With a wide range of hi-tech functions

already built in, Agile drives are complete and fully functional drives despite their small size. Thanks to intelligent design, the generous and advanced standard functions can be expanded by accessories and optional modules to extend versatility even further.

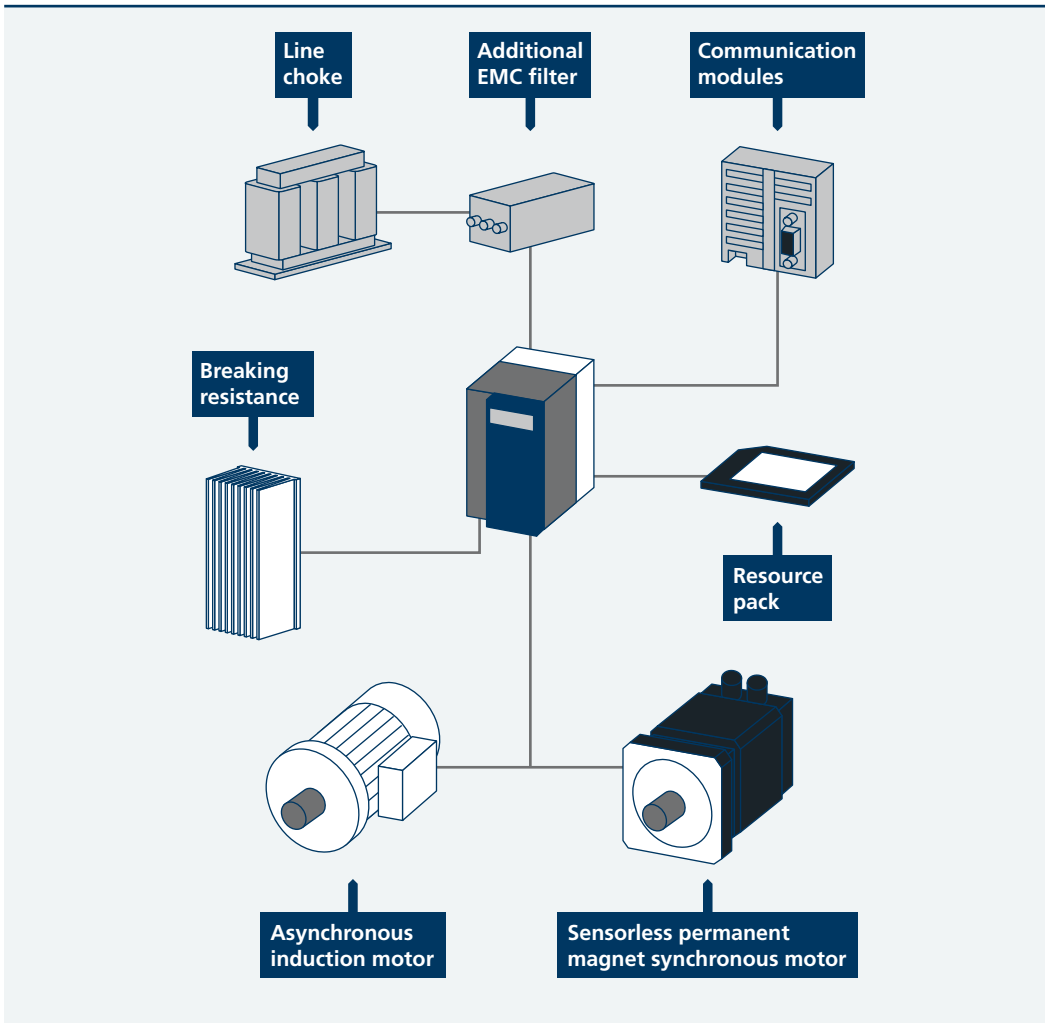

The Agile Series comes in three book-size models covering power requirements from 0.25 to 11 kW.



## Areas of application

Agile inverter drives can be used in all areas of industry, but are particularly suited to the following applications:



*Food & Beverage*



*Vertical stocking system*



*Textile*



*Wood*



*Packaging*



*Ceramics*

# Agile 402 series

## Selection guide

To order an Agile inverter drive, you need to specify the designation string corresponding to it. This comprises a series of fields that define exactly and uniquely what drive you need for your particular application. The first five fields identify the drive and its basic variants. These fields must

be mandatorily compiled in your order. You cannot leave any of these fields blank.

The next four fields on the other hand define optional configurations for your drive. To do without any of these options, simply leave the corresponding field blank.

## Designation Agile

### Basic variants

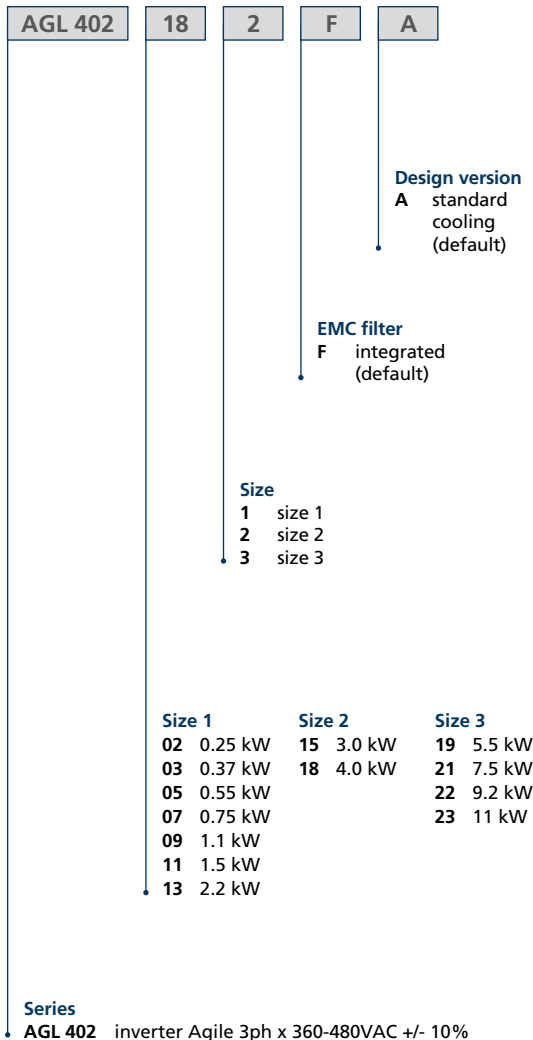

### Optional variants

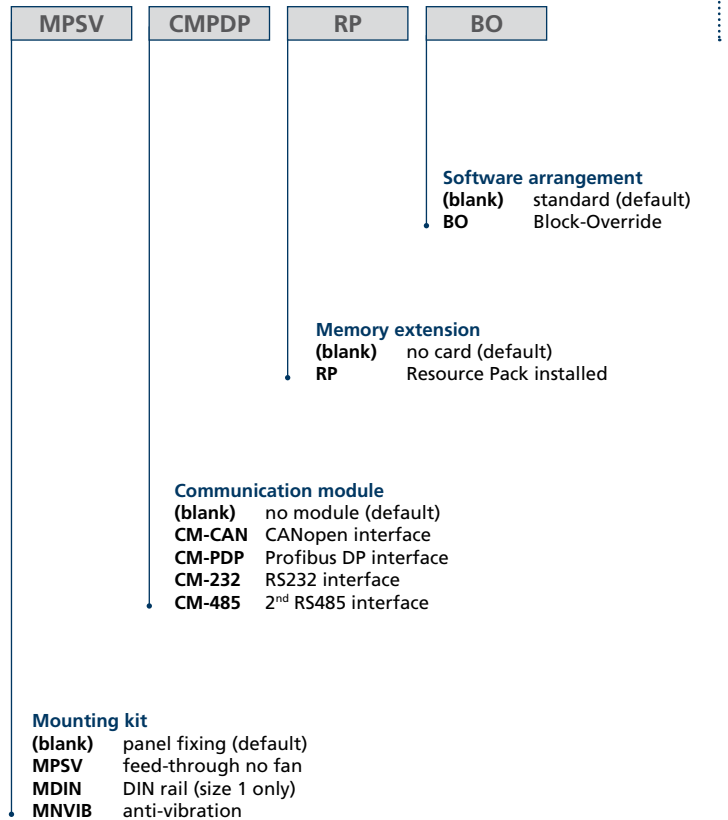

## Basic offer

Inverter	Power supply	Power	Filter	Dimensions	
	[V]	[kW]		[HxDxW]	
AGL402-02 1 F A	3ph x 400	0.25	Integrated	200 x 170 x 60	
AGL402-03 1 F A	3ph x 400	0.37	Integrated		
AGL402-05 1 F A	3ph x 400	0.55	Integrated		
AGL402-07 1 F A	3ph x 400	0.75	Integrated		
AGL402-09 1 F A	3ph x 400	1.1	Integrated		
AGL402-11 1 F A	3ph x 400	1.5	Integrated		
AGL402-13 1 F A	3ph x 400	2.2	Integrated	200 x 196 x 80	
AGL402-15 2 F A	3ph x 400	3.0	Integrated		
AGL402-18 2 F A	3ph x 400	4.0	Integrated	200 x 205 x 125	
AGL402-19 3 F A	3ph x 400	5.5	Integrated		
AGL402-21 3 F A	3ph x 400	7.5	Integrated		
AGL402-22 3 F A	3ph x 400	9.2	Integrated		
AGL402-23 3 F A	3ph x 400	11	Integrated		

# Innovation at the service of people

Agile inverter drives help bridge the gap between user and process by providing software and

hardware functions that simplify the management of complete systems.



Agile inverter process drives provide accurate sensorless vector control of asynchronous induction motors and permanent magnet synchronous motors, and also help manage the complete automation system by contributing to **energy saving, safety, maintenance and logic control.**

Agile drives are Bonfiglioli's solution to the needs of the standard drive market, and boast a special "all-in-one" formula that delivers exceptional versatility.

	Easy start up mode		Leader in room saving
	Energy stand-by		Integrated automation
	Safety inside		Sensorless brushless control
	Diagnostic fault scanner		Resource pack
	Downtime suppressor		E-served

## Innovation at the service of people



### Rapidity

It only takes a few minutes to install and set up an Agile drive. Users will find everything quick and easy, from control rack installation to software configuration, and will have the motor up and running in next to no time.

- Drilling template
- DIN rail mounting
- Clearly identified power terminals
- Pre-calibrated for Bonfiglioli motors
- Automatic and permanent adaptive tuning
- Pre-selection of application masks
- Customisable units of measure
- On-line help



### Energy saving

Agile helps reduce system energy requirements by minimising its own losses and those of the motor.

- Sensorless control of permanent magnet synchronous motors
- Automatic suspension of power stage with motor stopped
- Adaptation of voltage to suit the load applied to the motor shaft
- Minimum earth leakage



### Functional safety

Agile drives respect all the safety standards applicable to electronic variable speed control. In particular, Agile drives provide functional safety according to EN61508 SIL2 and electrical safety according to EN954-1 Cat. 3, in conformity to EN61800-5-2 product standards for torque elimination through the physical disconnection of the motor inside the inverter.

- Safe Torque Off
- Foolproof wiring



### Diagnostic analysis

Agile drives provide valuable support for the analysis of critical events affecting the drive itself and the system in which it is installed. They also incorporate a tool for monitoring, reconstructing and interpreting system dynamics.

- Alarm log
- Drive and motor status recovery
- Autodiagnosics after critical events
- Built-in multi-trace oscilloscope



### Failure prevention

Agile drives keep themselves and the system they are installed in under control, and make a generous contribution to maintenance efficiency by preventing unexpected machine stoppages.

- Estimation of capacitor maintenance intervals
- Estimation of cooling fan maintenance intervals

## Innovation at the service of people

---

### Space saving

The compact book size of Agile drives means significant space saving and great manoeuvrability inside the control cabinet.

- High power concentration
- Space saving in the control panel
- Book size
- Side by side installation
- Same height for all sizes



### Built-in PLC

Agile drives can perform simple and complex programmable logic operations on physical signals to their terminals and on internal software variables, and can combine these operations to create a functional program that can complement or replace a control panel PLC.

- Programmable logic functions
- Graphic block programming
- Cyclical operating system
- Accessible drive variables
- Input/output buffers



### Sensorless brushless

Agile vector drives can control even sensorless permanent magnet synchronous motors thanks to an innovative algorithm which provides full starting torque.



### Resource pack

Agile drives can be fitted with an MMC standard non-volatile flash memory expansion.

- MMC standard memory expansion card
- Any capacity cards supported
- Parameter copy function
- Integrated application documentation
- Integrated application software



### E-served management

Agile can be fully managed through Bonfiglioli's MOSAICO e-business platform that lets you select drives, order them and monitor delivery over the internet.

Technical training is also available through Bonfiglioli's HUB e-learning system. There is even a dedicated website for the distribution of newsletters.



## Synergy with Bonfiglioli motors

To set up a modern microprocessor drive, the electrical data of the motor have to be known for the drive's speed and torque control to use the right mathematical model for calculating control values.

To facilitate start-up and avoid the user having to find and then manually enter all the necessary data, Agile drives come with all the characteristics of equivalent Bonfiglioli motors pre-programmed.

The drive loads these as default values into the parameters that can be viewed using the built-in display or VPlus software.

The first time you switch the drive on, the motor parameter section will display a pre-programmed list of numeric values ready for use with Bonfiglioli motors. To use the drive with another motor, simply modify these parameters as required during the start-up procedure.

*Bonfiglioli default motor data*

Parameter	Data Set 0	Data Set 1	Data Set 2	Data Set 3	Data Set 4
369 Motor Type	1 - Asincrono				
370 Rated Voltage	400,0 V	400,0 V	400,0 V	400,0 V	400,0 V
371 Rated Current	5,4 A	5,4 A	5,4 A	5,4 A	5,4 A
372 Rated Speed	1410 U/min	1410 U/min	1410 U/min	1410 U/min	1410 U/min
373 No. of Pole Pairs	2	2	2	2	2
374 Rated Cosinus Phi	0,76	0,76	0,76	0,76	0,76
375 Rated Frequency	50,00 Hz	50,00 Hz	50,00 Hz	50,00 Hz	50,00 Hz
376 Rated Mech. Power	2,2 kW	2,2 kW	2,2 kW	2,2 kW	2,2 kW

A table of correspondence can be defined between each Agile drive size and the Bonfiglioli 4-pole

asynchronous or permanent magnet synchronous motor for which the drive is ready for use.

Inverter	Flanged/Compact asynchronous motor	Nominal power [kW]
AGL402-02 1 F A	BN63C4 / M05B4	0.25
AGL402-03 1 F A	BN71B4 / M15D4	0.37
AGL402-05 1 F A	BN80A4 / M1LA4	0.55
AGL402-07 1 F A	BN80B4 / M2SA4	0.75
AGL402-09 1 F A	BN90S4 / M2SB4	1.1
AGL402-11 1 F A	BN90LA4 / M3SA4	1.5
AGL402-13 1 F A	BN100LA4 / M3LA4	2.2
AGL402-15 2 F A	BN100LB4 / M3LB4	3.0
AGL402-18 2 F A	BN112M4 / M3LC4	4.0
AGL402-19 3 F A	BN132S4 / M4SA4	5.5
AGL402-21 3 F A	BN132MA4 / M4LA4	7.5
AGL402-22 3 F A	BN132MB4 / M4LB4	9.2
AGL402-23 3 F A	BN160MR4 / M4LC4	11



## VPlus engineering software

VPlus software provides a common programming and monitoring platform for all Bonfiglioli inverter drives. Now in version 7, VPlus provides an effective aid to configuring, diagnosing and controlling your drive from a PC, and also provides a range of practical tools to manage the resources of your Agile inverter completely and efficiently.

Just connect the computer to the drive via the ASK-USB accessory cable and launch VPlus. Serial communications are quickly established and entire drive setup is displayed on the computer monitor along with a toolbar containing drive control functions.

VPlus supports multiple and simultaneous communications between the same number of drives as there are USB ports on the computer, as well as a connection to the Bonfiglioli drive field bus.



### VPlus functions

Simply click on the relevant icons to:

- Upload parameter files to the drive
- Configure drive parameters
- Read current parameters values
- Run the motor setup
- Open the inverter monitoring window
- Display the 4-trace oscilloscope
- Open the inverter status window
- Program the drive's built-in PLC

Each of the above functions opens a new window that remains visible along with all the others to permit a global view of drive functions.

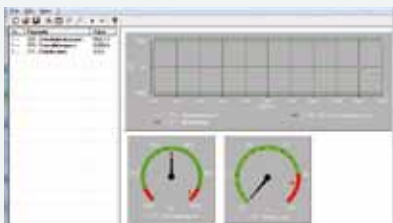

### Graphic control panel

Current drive functioning values can be displayed numerically or graphically, as the user wishes.



### IO monitoring

The IO monitor window lets you view the inverter's digital inputs and outputs and motor status.

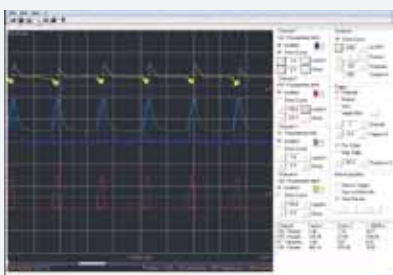

### Built-in oscilloscope

VPlus software incorporates a digital oscilloscope with the following functions:

- 4 programmable traces
- 2 ms sampling rate
- manual/automatic X-Y axis scaling
- programmable threshold triggers
- auxiliary cursors
- print function
- data export in CSV format
- image saving

The oscilloscope enhances the functionality of the Agile drive's own diagnostics by permitting the run-time display of any physical or virtual variable handled by the drive and the real time analysis of the entire process driven by the motor shaft.



# VPlus engineering software

## Comparative analysis

To make it easier for users to analyse application parameters off-line, VPlus also provides a file compare function that identifies differences and similarities.

## On-line help

To guide users in programming the drive, VPlus also features an on-line help that explains the meaning and the effect of each drive parameter. Simply click on the desired parameter to access help on it.

## Application masks

To help users set up the drive for frequent applications quickly and easily, VPlus includes a library of application masks showing only those software parameters that are strictly necessary for application start-up.

Users benefit from a schematic description of the functionalities provided by the selected mask as well as the parameters needed to configure it.

## Built-in graphic PLC

The internal PLC of Agile drives can be programmed using VPlus software. The various functional blocks processed by the PLC's operating system can be programmed in VPlus simply by selecting the corresponding page.

A graphic editor in VPlus lets you load and drag all the logic blocks recognised by the drive to form the functional program that the PLC needs to implement in RUN mode.

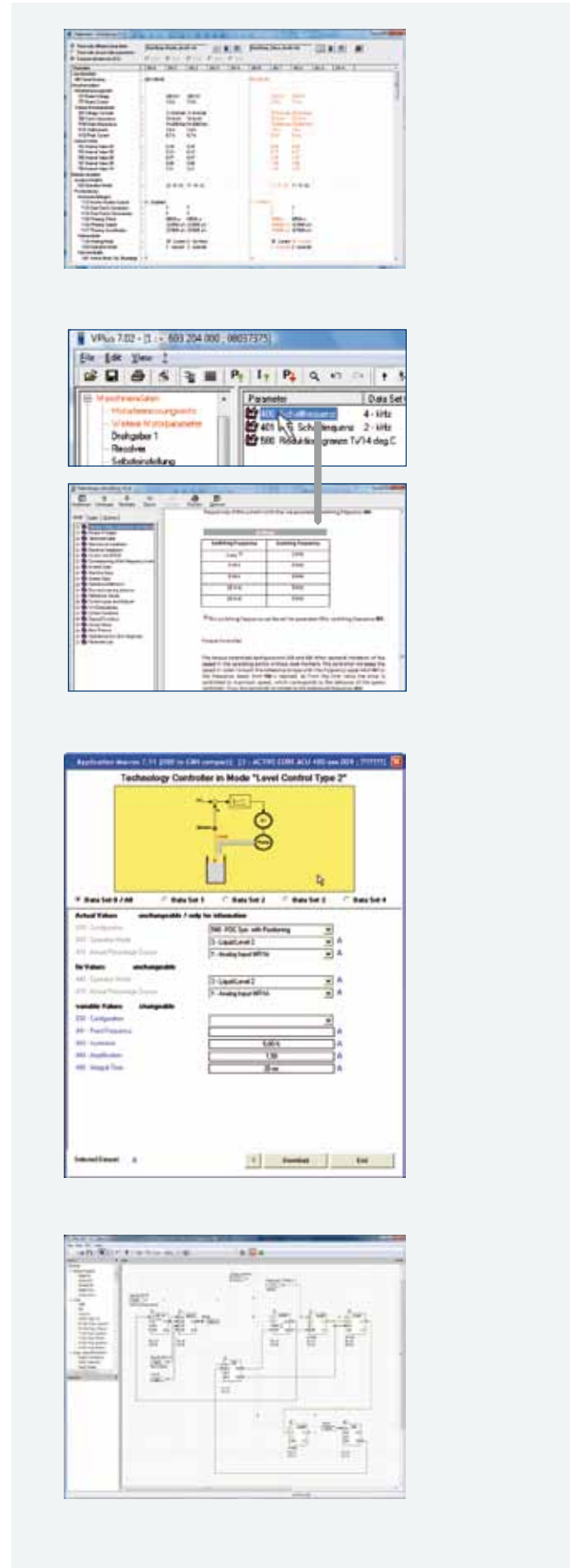
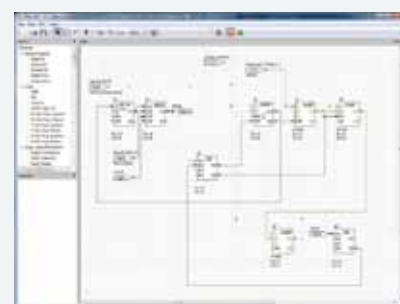
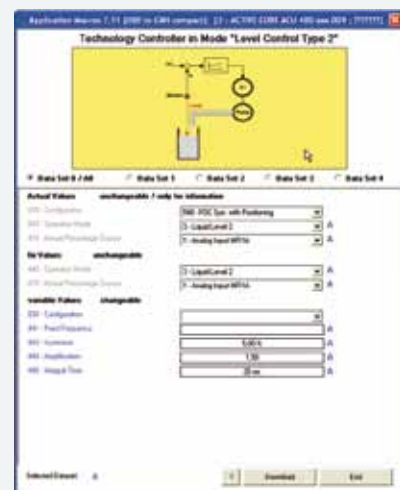
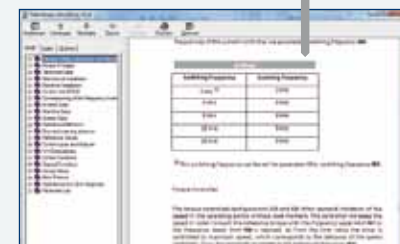
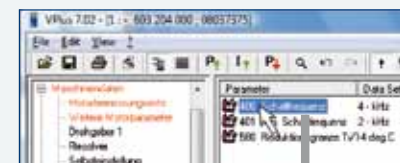

# Sensorless control of permanent magnet synchronous motors

In brushless motor control, the exact angular position of the rotor must be known at all times for the drive to commutate the inverter phases. The conventional method for tracking rotor position is to incorporate an encoder or resolver inside the servomotor to provide the drive with the necessary electrical signals. This, however, requires extra cabling, data interfaces and controls. Thanks to innovative technology, Agile drives can control brushless servomotors without the need for sensors, eliminating the cost of superfluous components, wiring, interfaces and controls. Agile

drives use efficient algorithms to calculate the instantaneous angular position of the motor shaft from measurements of the current absorbed by the motor. This gives significant savings in costs, eliminates the criticalities inherent in sensors, simplifies the control system and reduces energy consumption by permitting a more efficient motor architecture to be used. By combining analytic techniques to reconstruct the electrical status of the motor and functional analyses of its magnetic circuit, Agile drives provide effective vector control of torque.

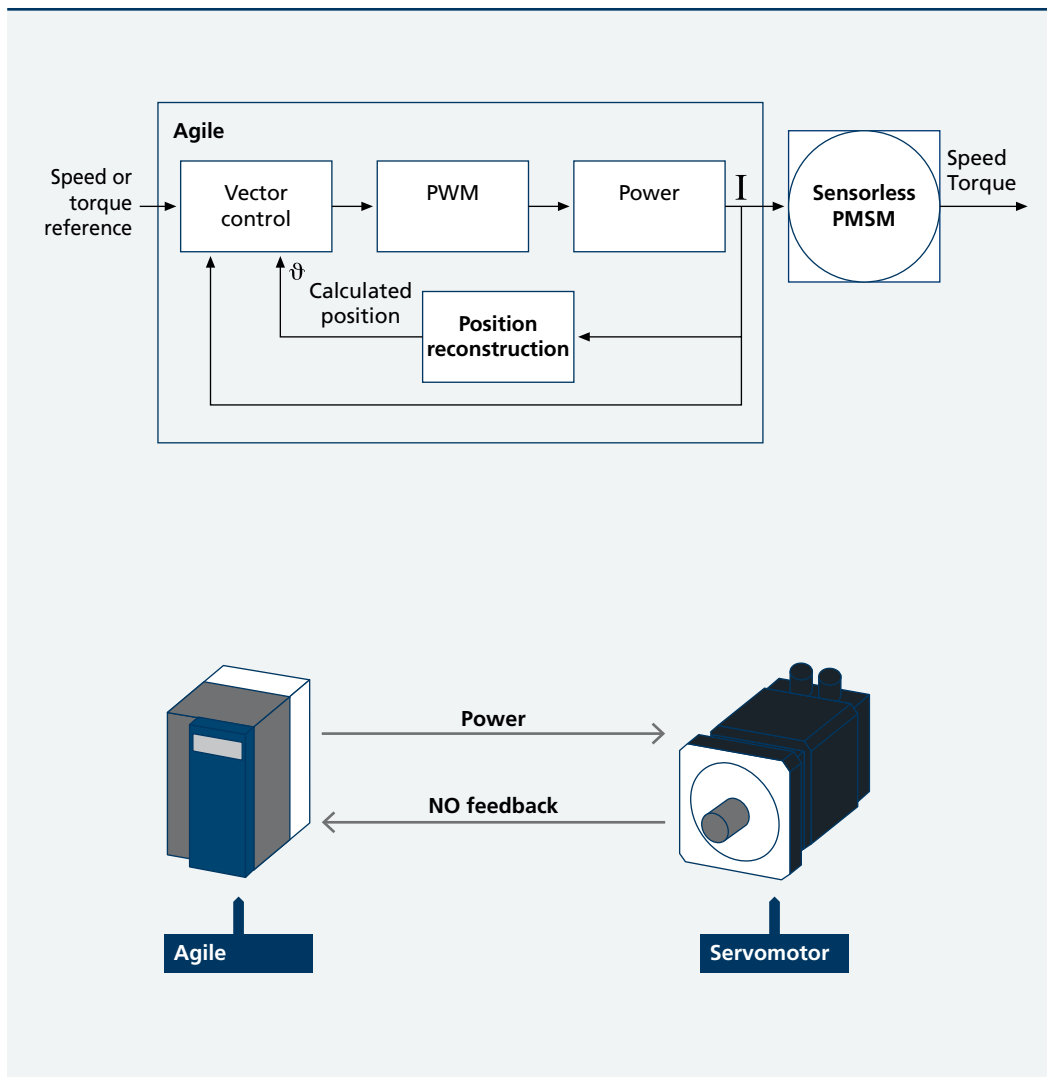

## Energy saving



Energy saving is a common objective in all areas of manufacturing. No company is exempt from the need to save money and help the environment at the same time.

If energy saving is your aim, Agile is the drive to help you achieve it.

AgileE drives incorporate numerous functions for

### Sensorless control of permanent magnet synchronous motors

Modern brushless motors are extremely efficient thanks to a design that favours excellent electromechanical energy conversion and minimises heat loss through the rotor.

Agile drives are designed to bring the benefits of

reducing the electrical energy needed to power motors and can make a major contribution to energy saving in any plant.

Bonfiglioli knows exactly what factors determine a drive's energy efficiency and how to achieve major energy savings. Now all this know-how has been concentrated into a single product.

brushless motor technology within the reach of all users.

Agile drives do not need encoders or resolvers on board the motors to control them. They can therefore save money by eliminating superfluous components, without any loss of dynamic motor performance.

### Standby mode

Motors are often used in applications involving intermittent functioning cycles characterised by alternating run and rest phases. Under conditions like these, the drive itself has to remain powered on in order to be ready to start the motor as soon as the application demands.

To avoid unnecessary energy consumption during motor rest periods without actually disconnecting

power to the inverter, Agile drives use a special auto-standby function, which leaves the inverter in a "sleep" condition with only its control circuits active, a condition in which energy consumption is minimal. A programmable delay can be adjusted by users in order to extend the standby mode even to keypad display. As soon as a start command is received, the inverter "wakes up" immediately to power the motor.

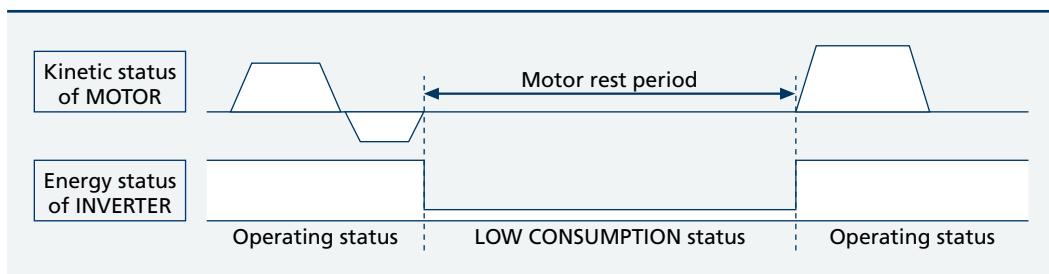

### Power managing

Motor efficiency is significantly conditioned by the quality of the power supply.

Agile drives use control to reduce motor voltage to suit applied loads without compromising performance. This reduces motor losses,

consumption and maintenance requirements and helps extend motor life. For example, if the motor is run up to rated speed at zero load, there is no need to apply full rated voltage. The minimum voltage compatible with the needs of motor magnetisation is all that is needed.

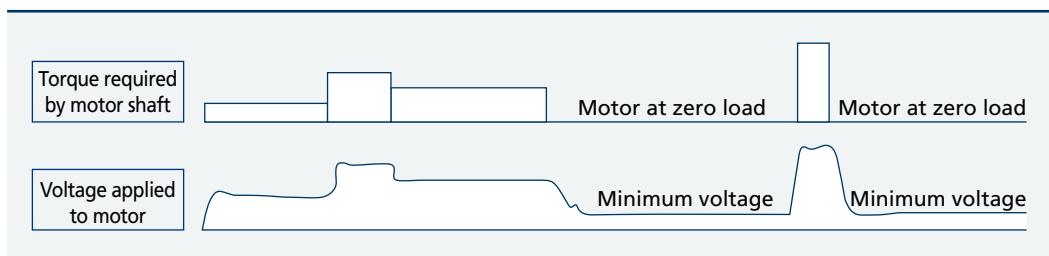

### Minimum earth leakage

Agile drives are equipped with a built-in, low leakage current EMC filter that conforms to all

applicable standards. By significantly reducing earth leakage, this filter also maximises energy savings under all operating conditions.



# A drive with a PLC built in

Modern PLCs are extremely evolved devices with high calculation and interface capacities. The problem is that they need qualified, expert personnel to convert the needs of the machine into sequences of PLC instructions. These may even have to be encoded according to different proprietary programming standards. The inverter is becoming one type of actuator to which PLCs can delegate the dynamic control of an axis in synchronisation with other parts of the machine.

Agile drives guarantee efficient motor control and incorporate a programmable logic controller that can be used to complement or replace a conventional control panel PLC. In the heart of every Agile drive is a PLC capable of performing multiple logic operations (AND, OR, XOR) and functions (counters, timers, comparators, multiplexers, decoders, oscillators, etc.). These can be combined using a graphic editor to create complex functions. The result is an intelligent local controller capable of handling the drive's own internal variables (currents, frequencies, machine statuses, etc.), I/O signals to and from the

terminals, and multiplexed data exchanged over a field bus.

The intuitive graphic editor allows even non-expert users to program the PLC of an Agile drive without having to learn complicated programming languages that very few can master. Agile users do not have to rely on others to program their drives. Agile drives are powerful and intelligent and, by relieving the main control panel PLC of local tasks, conform perfectly to the concept of **distributed logic**.

The Agile PLC recognises and handles 120 different functions, which can be used within 32 programmable functional modules (indexes).

Each module has a maximum of 4 inputs, 2 outputs and 2 configuration parameters. When the drive is switched on, its operating system indexes all the active modules in sequence, taking only 1 ms per module. Each module is implemented by running all its instructions in sequence. When one module has been completed, the OS moves on to the next, and so on.

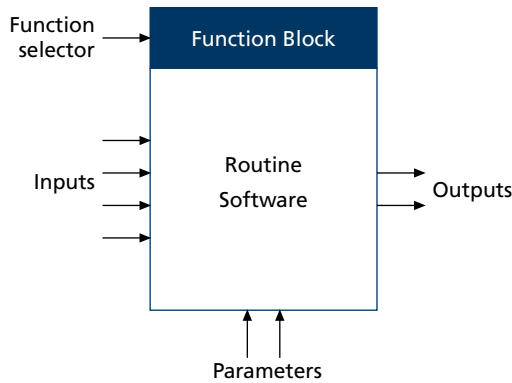
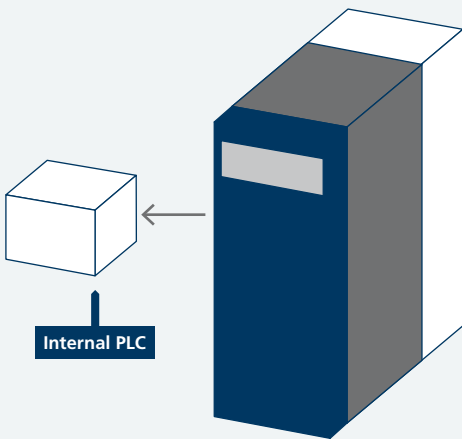

## A drive with a PLC built in

The OS scans input and output buffers, samples input signals and executes output signals before it indexes the sequence of active modules.

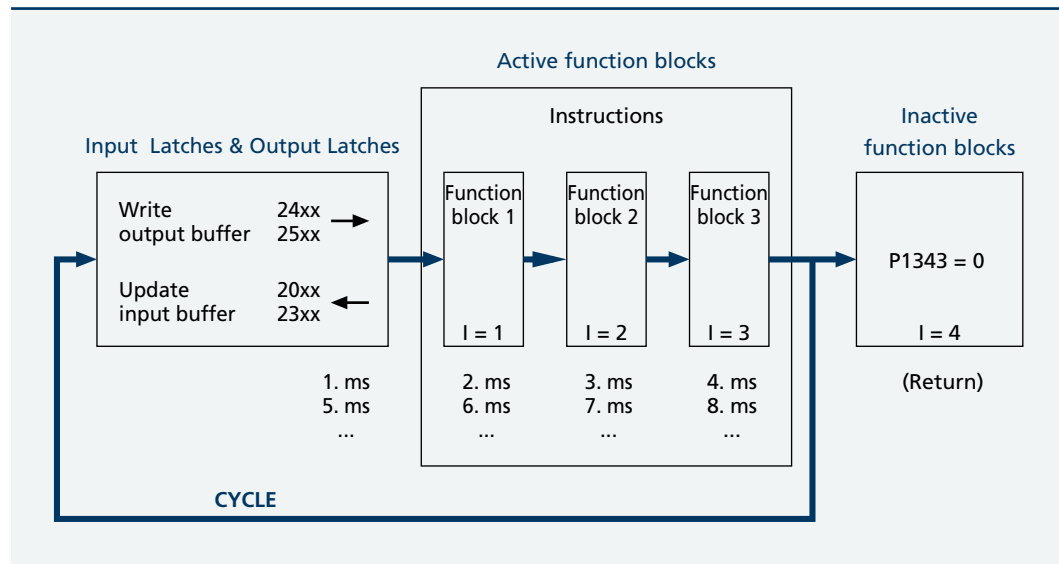

As in any control panel PLC, cycle management is entrusted to the operating system and is independent of all other processes managed by the CPU.

The program is therefore deterministic and scan time proportional to the number of active function blocks. In any automation process, the cycle period can be calculated by summing the 1-ms delays introduced by each function block.

Agile PLC functions can be programmed using VPlus software, which graphically displays the program to which the drive's memory corresponds in real time.

VPlus software also provides a page that can be used to load graphic function blocks and link them together to create complex logic networks for use by the drive.

The Agile PLC supports and processes all the variables used by the drive software, including I/O variables, strings exchanged over the field bus and numeric motor control values. The PLC is therefore perfectly able to exchange signals with external devices like sensors, actuators, inverters, PLCs, PC's, etc.) as well as with the drive itself.

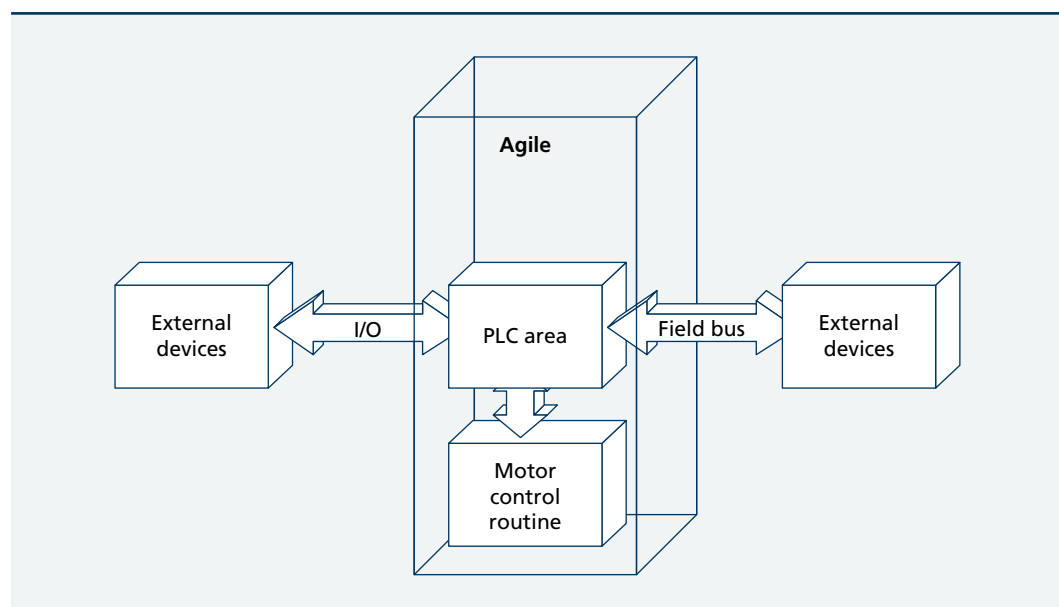

## Integrated safety thanks to Safe Torque Off

The Machinery Directive establishes the **safety requirements** that all machines must conform to before they can carry the CE mark and be manufactured and sold within the European Community.

In particular, all machine movements must be monitored by a safety system capable of intervening in an emergency to stop motors and **disconnect power** until normal operating conditions can be restored.

Safety systems must intervene effectively and guarantee physical disconnection between motor and power source. They must also be **reliable**, i.e. never fail to function.

Standards EN 954-1 and EN 61508 regulate safety system effectiveness and reliability respectively. These standards assign **two distinct value scales** to effectiveness and reliability (Category and Level), ensuring that machine manufacturers design in a degree of safety adequate to the needs of the application.

In a conventional drive, to guarantee the effective disconnection of the motor and the absence of turning moment at its shaft, the safety system uses remote power switch outside the drive to insulate the motor electrically.

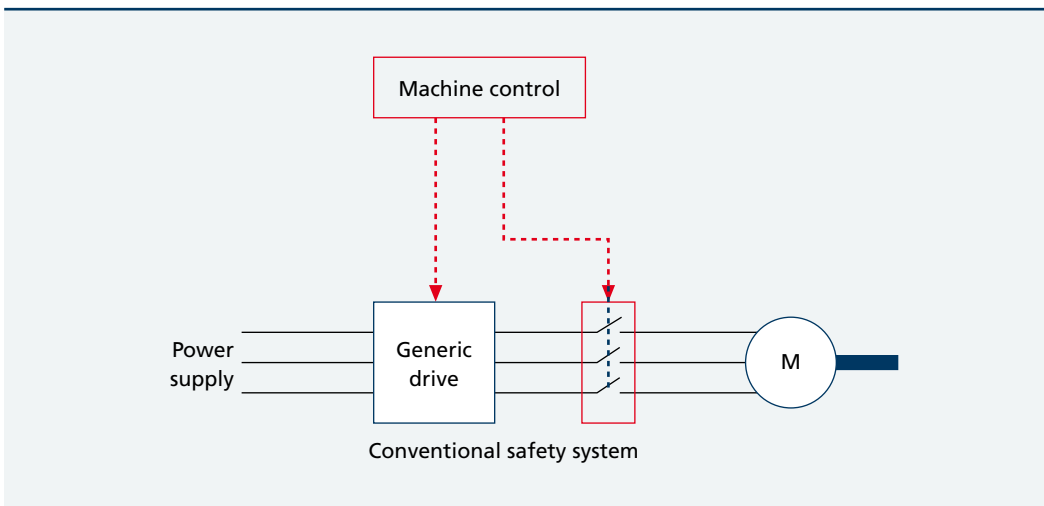

Bonfiglioli has integrated the Safe-Torque-Off system (STO, EN61800-5-2) in Agile drives in response to market demand to reduce the size of control panels, minimise the number of operating components, simplify control, and eliminate the

mechanical stress caused by the sudden application of the brake while the shaft is still turning. In an emergency this system disconnects the motor in compliance with EN954-1 Cat. 3 and EN61508 SIL2, without the need for external contactor.

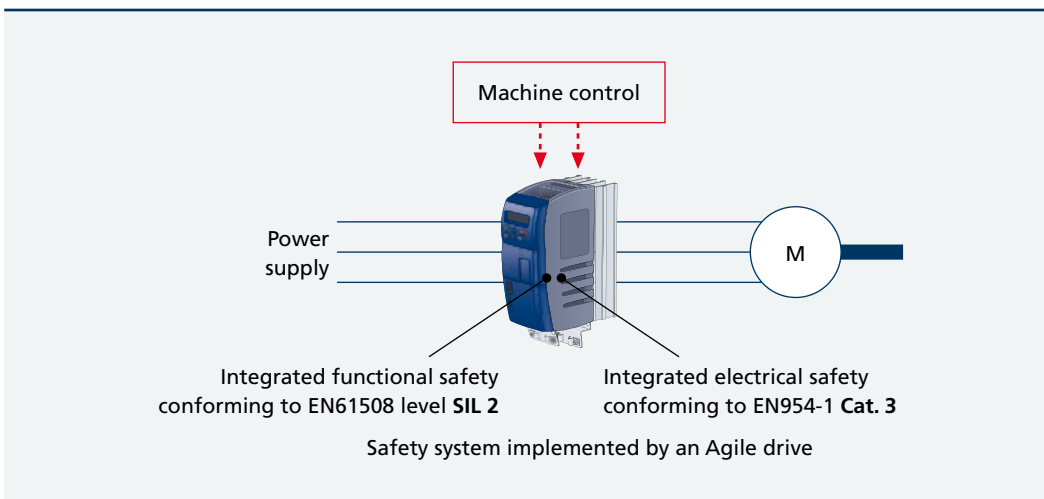

Integrated functional safety conforming to EN61508 level **SIL 2**

Integrated electrical safety conforming to EN954-1 **Cat. 3**

## Integrated safety thanks to Safe Torque Off

Agile drives incorporate redundant functional logic and hardware architecture to disconnect the motor safely and stop it in the minimum time possible.

The simultaneous activation of two digital inputs, STOA and STOB, corresponding to two identical but distinct electrical paths, causes the software to recognise an external emergency condition,

suspend the generation of PWM pulses and physically disable the optoisolators that transmit signals to the IGBT drivers, all in less than 10ms. This brings the motor to a controlled stop, followed by total isolation from the inverter. Any alarm condition arising inside the drive also generates an emergency stop in the same way, irrespective of STOA and STOB signals.

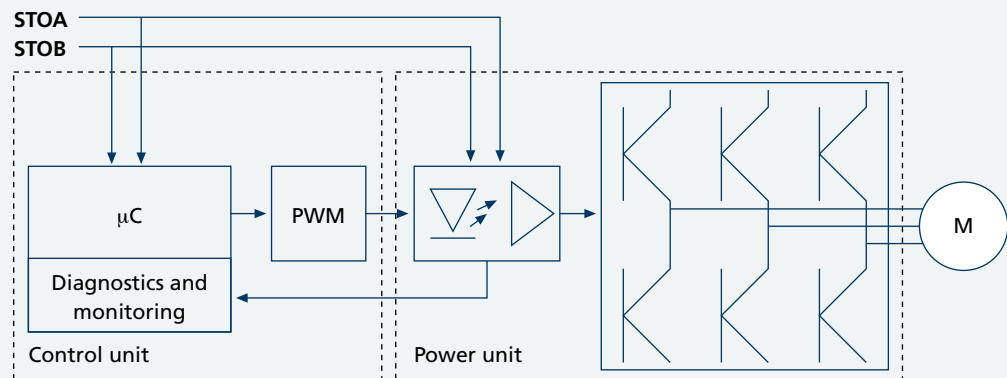

STOA	STOB	Effect
0	0	Safe Torque Off active; motor stopped and isolated
0	1	Safe Torque Off in stand-by; the software awaits a second signal: after 5-s wait time with no signal, the drive generates an alarm
1	0	
1	1	Safe Torque Off deactivated; the motor functions conventionally

## Selective Multi-Motor Control (SMMC)

Industrial applications often require a number of axes to be controlled separately and driven one at a time in a predefined sequence in which no two motors operate simultaneously.

In conventional systems of this type, each individual axis has to be controlled by its own drive, configured to power its motor for a set time and then to remain inactive while the control sequence passes on to the next axes. The process controller must therefore send each drive its own set of commands and must also transmit the necessary reference signals over a corresponding number of analog ports or network addresses. This requires a high level of redundancy in system

components, cabling and control software and results in significant energy consumption.

Agile drives are specially designed to provide efficient control of complex systems comprising multiple but non-simultaneous motors. Agile drives can handle four separate motors even with different electrical characteristics, reserving a dedicated area of memory to the control of each. The architecture of Agile drives lets you store simultaneous configurations for all four motors and control them independently at separate times according to independent criteria and strategies, but using the same power hardware.

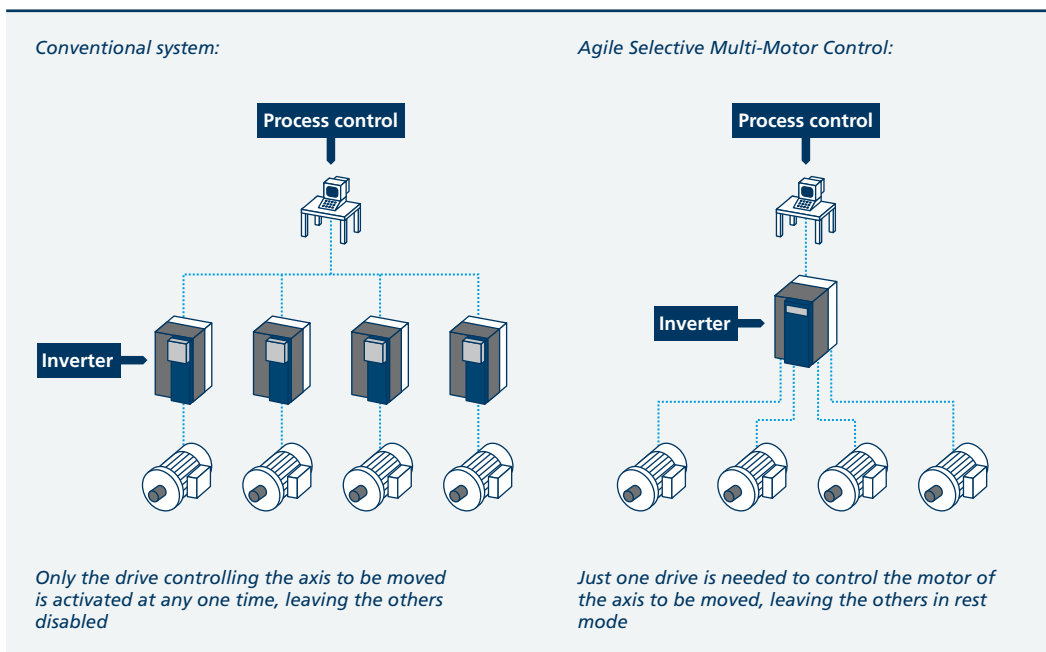

By using two digital inputs in binary combination mode, users can activate the drive's parameter configuration corresponding to just one of the four motors, thus excluding the other three. The currently active control algorithm (V/Hz,

sensorless vector control, sensorless brushless motor control) controls the selected motor and drives it according to the parameter settings in the corresponding dataset.



## Selective Multi-Motor Control (SMMC)

The drive's digital outputs can be used to switch the cabling upstream from the motors to ensure

that only one motor is ever connected to the drive at any one time.

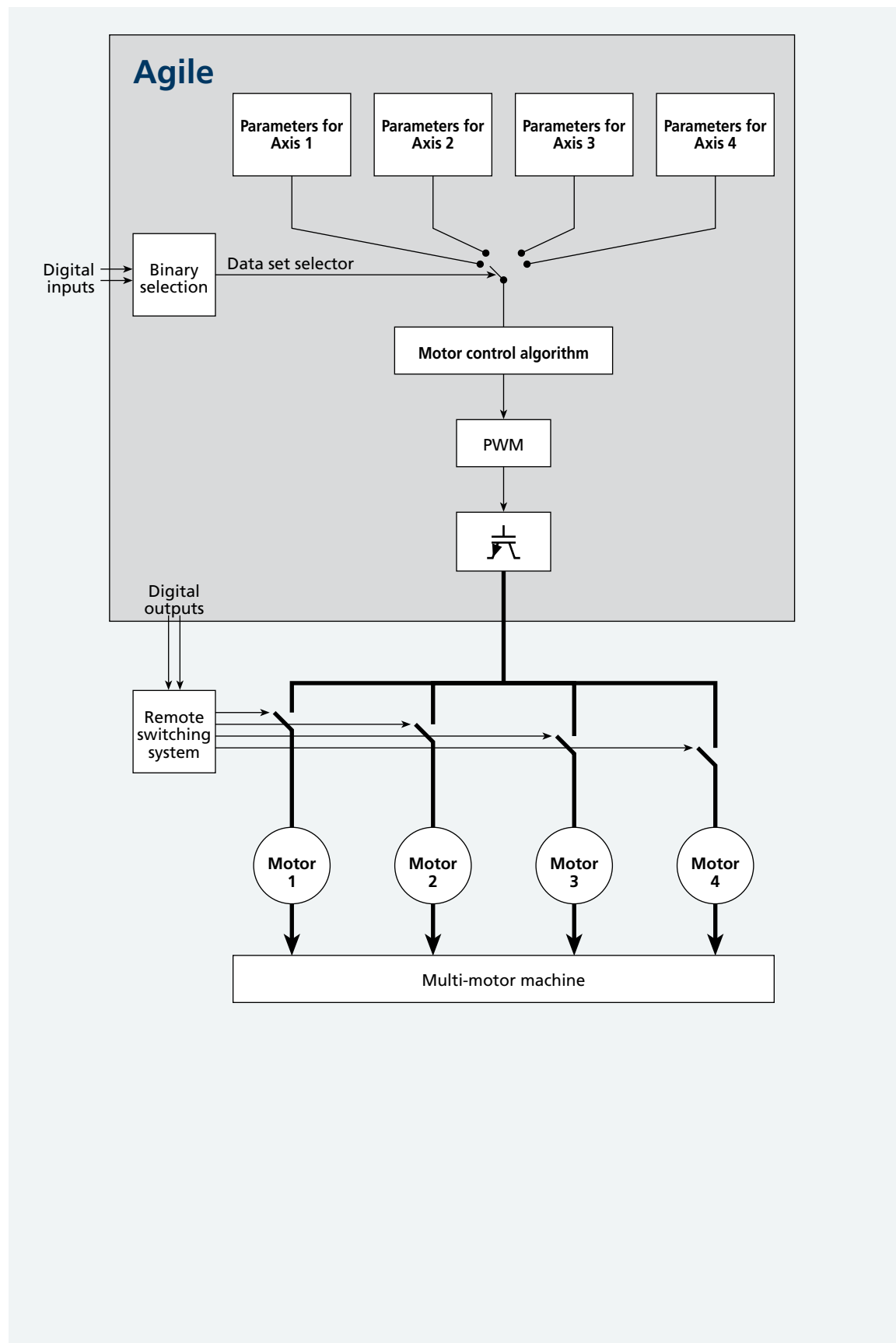

## Resource pack

As with all microprocessor systems, the inverter firmware, all the motor control routines and all the drive functions are contained in the internal memory of Agile drives.

This main memory is strictly reserved for the drive's operating system. Agile drives, however, also support a removable MMC memory card or Resource Pack that conforms to SPI protocol and can be used to save and organise data as the user wishes.

A slot is provided in the front panel of the Agile drive for inserting the MMC card. Users are free to

select and buy whatever card they wish. Cards can be used for any of the following purposes:

- data exchange with the drive
- storage of operator manuals, catalogues and technical documentation
- saving configuration files to and from the drive
- saving oscilloscope traces
- storing any other data relevant to the application

There are no limits to memory capacity. Agile drives support all common card sizes.

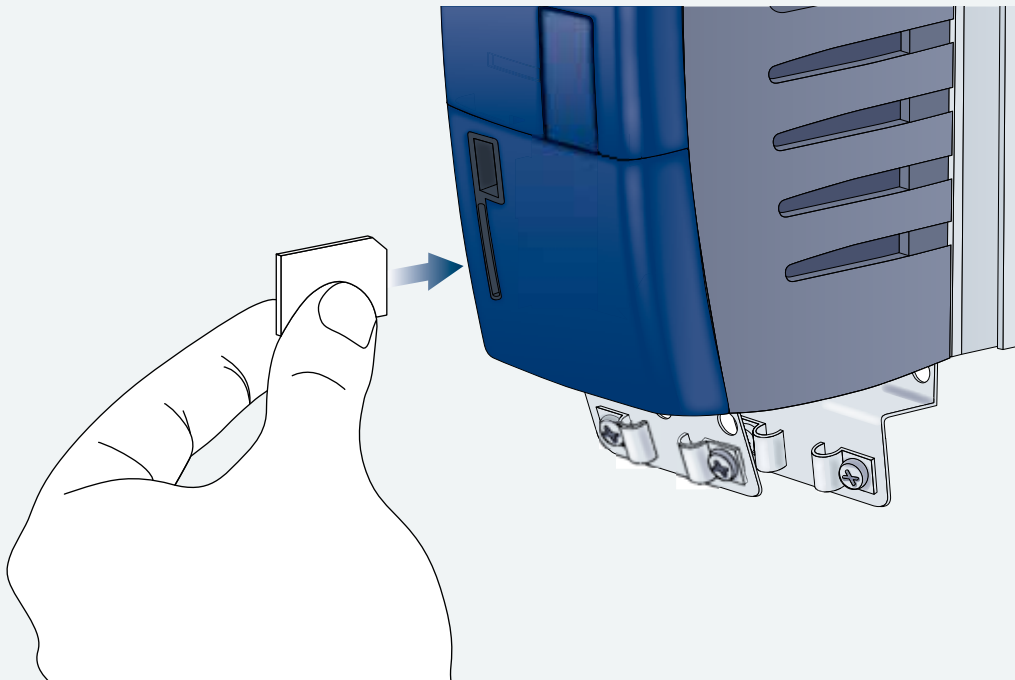

## Functional layout

The terminals, connectors and push-buttons of the Agile user interface are located where they are easily accessible without having to use tools. The power terminals (inverter power input and motor power output) are located at the top and bottom of the drive and are individually marked with clearly visible symbols to ensure correct wiring.

Control terminals are located at the front of the unit and are easily accessible simply by removing the blue push-on protective cover.

A keypad, elegantly integrated in the drive body, provides six function keys for drive programming,

monitoring and control.

The drive is also equipped with an RJ45 connector for the RS485 Modbus serial interface as well VABus and a slot for an MMC memory card that can be used to copy drive parameters.

An RS232 port, Profibus DP or CANopen communication port can be fitted as optionals. If one or more of these ports is required, installation is quick and easy and only requires the protective cover to be removed to access the slots beneath the operator panel in the front of the drive. The installation of these optional modules does not alter the overall dimensions of the drive.

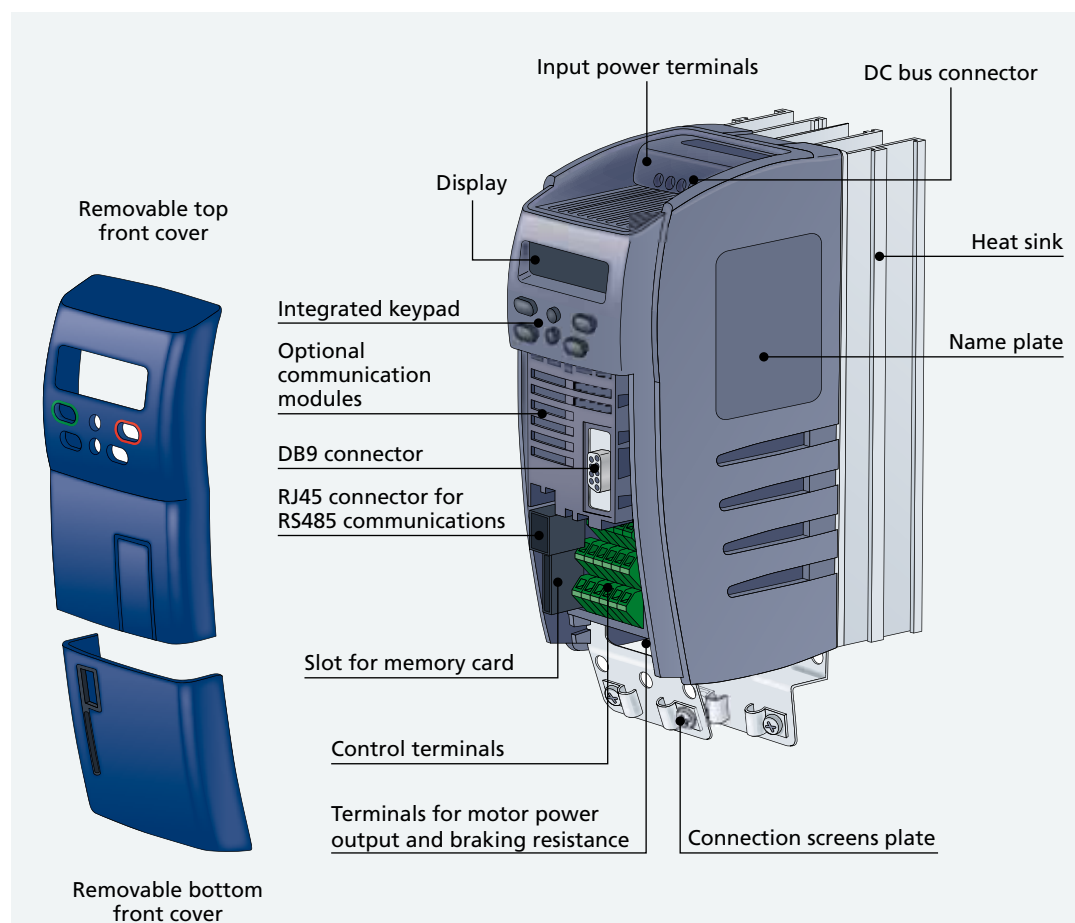

## General technical data

### Environment

- Transport and storage temperature -25°C ... 55°C
- Operation temperature: 0°C - 40°C (40°C-55°C with derating)
- Environment class: 3K3 (EN60721-3-3)
- Relative humidity 5%...95%, no condensation
- Altitude of installation: up to 3000m (over 1000m with derating)
- Storage conditions: according to EN50178
- Degree of protection: IP20

### Electrical

- Rated mains voltage: in the range 323 .... 528 V
- Rated mains frequency: in the range 45 ... 69 Hz
- Overload current: 150% nominal current
- Peak current: 200% nominal current
- Electric protections: short circuit / earth
- Braking transistor: built-in on standard device

### Standards

- CE conformity: Low voltage directive 2006/95/EC and EN50178 / DIN VDE 0160 and EN61800
- Interference immunity: according to EN61800-3
- UL approval: according to UL508c

### Connections

The Agile drive is fitted with power input terminals for connection to the mains, power output terminals for driving the motor and signal terminals for inverter control, subdivided into four sections.

### Power terminals

The power terminals are located at the top and bottom of the unit.

Mains input power is connected to the top of the drive where a DC-bus connection is also provided. The power output cables to the motor are connected to the bottom of the drive where there is also a connection for a braking resistance if required.

Just as on ACT and ACU drives, this effective separation of input and output power terminals helps prevent mis-wiring through human error.



## General technical data

### Control terminals

Control signals are distributed over four separate terminal strips, located under the drive's removable front cover. Terminals include:

- 6 digital inputs
- 1 configurable digital I/O port
- 2 configurable multifunctional A/D inputs
- 1 digital output
- 1 configurable multifunctional A/D/pulse output
- 1 auxiliary voltage supply input
- 2 voltage supply outputs
- 1 Systembus/CAN communication interface

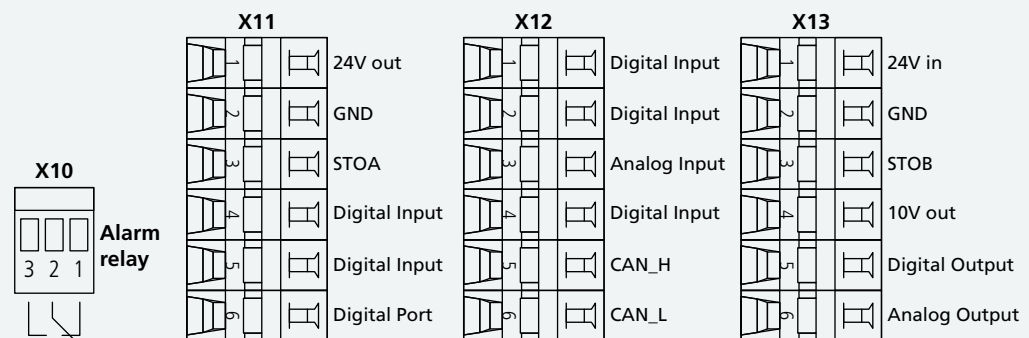

### Terminal Default function

Terminal	Default function
X13.1	Auxiliary 24 VDC input
X13.2	GND for X13.1
X13.3	Digital input for Safe Torque Off B
X13.4	10 VDC output
X13.5	Multifunction Digital Output (default = RUN state)
X13.6	Multifunction Analog Output (default = Actual speed)
X12.1	Multifunction Digital Input (default = data set change-over bit 1)
X12.2	Multifunction Digital Input (default = fixed frequency change-over)
X12.3	Voltage Configurable Analog/Digital Multifunction Input (default = frequency reference)
X12.4	Voltage Configurable Analog/Digital Multifunction Input (default = motor thermal contact)
X12.5	Systembus/CAN signal +
X12.6	Systembus/CAN signal -
X11.1	24VDC output
X11.2	GND for X11.1
X11.3	Digital input for Safe Torque Off A
X11.4	Multifunction Digital Input (default = start clockwise)
X11.5	Multifunction Digital Input (default = start anticlockwise)
X11.6	Digital Configurable Input/Output (default = data set change-over bit 2)
X10.1	Normally closed Alarm Relay contact
X10.2	Alarm relay switching contact
X10.3	Normally open Alarm Relay contact

## General technical data

The Agile Series covers a power range of 0.25 to 11 kW, divided into three sub-ranges, each covered by one physical drive size. Each drive size can therefore satisfy the needs of different power ratings to offer a suitable solution for all applications.

The three physical drive sizes are identical in height and depth but differ in width because of the different power modules combined with them. The sizes are easily identifiable for the same reason.

Series	Power supply
AGL 402	3ph 400V

	AGL402- ... 1 F A Size 1	AGL402- ... 2 F A Size 2	AGL402- ... 3 F A Size 3
Rating	0.25 kW	3.0 kW	5.5 kW
	0.37 kW	4.0 kW	7.5 kW
	0.55 kW	-	9.2 kW
	0.75 kW	-	11 kW
	1.1 kW	-	-
	1.5 kW	-	-
	2.2 kW	-	-

## AGL402 - Technical data (from 0.25 to 2.2 kW)

AGL402-			02	03	05	07	09	11	13	
Size 1										
<b>Output, motor side</b>										
Recommended motor power	$P_n$	kW	0.25	0.37	0.55	0.75	1.1	1.5	2.2	
Motor rated current	$I_n$	A	0.8	1.2	1.5	2.1	3.0	4.0	5.5	
Current overload 60 s	$I_{OL}$	A	1.2	1.8	2.3	3.2	4.5	6.0	8.2	
Current overload 1 s	$I_{pk}$	A	1.6	2.4	3.0	4.2	6.0	8.0	11.0	
Output voltage	$U_n$	V	3 x (0...U)							
Output frequency	$f_n$	Hz	From 0 to 1000							
Switching frequency	$f_c$	kHz	From 2 to 16							
Protections	-	-	Short circuit phase to phase / phase to earth							
DC-bus current 60 s	$I_{DCOL}$	A	1.1	1.7	2.1	3.0	4.8	6.4	8.7	
<b>Input, mains side</b>										
Mains configuration	-	-	TT, TN, IT							
Mains rated voltage	U	V	323 ... 528							
Mains rated frequency	f	Hz	45 ... 69							
Input rated current	I	A	0.8	1.2	1.8	2.4	2.8	3.3	5.8	
Fuses 3ph/PE	I	A	6	6	6	6	6	6	10	
DC-bus rated voltage	$U_{DC}$	V	U x 1.41							
Overvoltage category	-	-	DIN EN 50178 III							
<b>General</b>										
Short circuit / earth protection	-	-	Yes, unlimited							
Mounting position	-	-	Vertical							
Degree of protection	-	-	IP 20 (EN 60529)							
Dimensions	HxWxD	mm	200 x 60 x 170							
Fan cooling	-	-	No				Yes			
<b>Environment</b>										
Coolant temperature	$T_n$	°C	From 0 to 40 (40 ... 55 with derating)							
Humidity	-	%	5 ... 85, no condensing							
Power dissipation	-	W	19	29	42	53	70	89	122	
<b>Options &amp; accessories</b>										
Brake-chopper	-	-	Integrated							
Line choke	-	-	Option							
EMI filter	-	-	class A (EN 61800-3) integrated / class B option							
Braking resistor	-	-	Option							
Operator panel	-	-	Integrated							
Communication interfaces	-	-	RS485 Modbus integrated / Systembus integrated / CANopen integrated RS232 option / Profibus DP option							

## AGL402 - Technical data (from 3 to 4 kW)

AGL402-

15

18

Size 2

### Output, motor side

Recommended motor power	$P_n$	kW	3.0	4.0
Motor rated current	$I_n$	A	7.5	9.5
Current overload 60 s	$I_{OL}$	A	11.2	14.2
Current overload 1 s	$I_{pk}$	A	15.0	19.0
Output voltage	$U_n$	V	3 x (0...U)	
Output frequency	$f_n$	Hz	From 0 to 1000	
Switching frequency	$f_c$	kHz	From 2 to 16	
Protections	-	-	Short circuit phase to phase / phase to earth	
DC-bus current 60 s	$I_{DCOL}$	A	4.8	6.4

### Input, mains side

Mains configuration	-	-	TT, TN, IT	
Mains rated voltage	U	V	323 ... 528	
Mains rated frequency	f	Hz	45 ... 69	
Input rated current	I	A	6.8	7.8
Fuses 3ph/PE	I	A	10	10
DC-bus rated voltage	$U_{DC}$	V	U x 1.41	
Overvoltage category	-	-	DIN EN 50178 III	

### General

Short circuit / earth protection	-	-	Yes, unlimited	
Mounting position	-	-	Vertical	
Degree of protection	-	-	IP 20 (EN 60529)	
Dimensions	HxWxD	mm	200 x 80 x 196	
Fan cooling	-	-	Yes	

### Environment

Coolant temperature	$T_n$	°C	From 0 to 40 (40 ... 55 with derating)	
Humidity	-	%	5 ... 85, no condensing	
Power dissipation	-	W	133	167

### Options & accessories

Brake-chopper	-	-	Integrated	
Line choke	-	-	Option	
EMI filter	-	-	class A (EN 61800-3) integrated / class B option	
Braking resistor	-	-	Option	
Operator panel	-	-	Integrated	
Communication interfaces	-	-	RS485 Modbus integrated / Systembus integrated / CANopen integrated RS232 option / Profibus DP option	



## AGL402 - Technical data (from 5.5 to 11 kW)

AGL402-	19	21	22	23		
Size 3						
<b>Output, motor side</b>						
Recommended motor power	$P_n$	kW	5.5	7.5	9.2	11
Motor rated current	$I_n$	A	13.0	17.0	20.0	23.0
Current overload 60 s	$I_{OL}$	A	19.5	25.5	30.0	34.5
Current overload 1 s	$I_{pk}$	A	26.0	34.0	38.0	46.0
Output voltage	$U_n$	V	3 x (0...U)			
Output frequency	$f_n$	Hz	From 0 to 1000			
Switching frequency	$f_c$	kHz	From 2 to 16			
Protections	-	-	Short circuit phase to phase / phase to earth			
DC-bus current 60 s	$I_{dCOL}$	A	21.0	27.0	32.0	37.0
<b>Input, mains side</b>						
Mains configuration	-	-	TT, TN, IT			
Mains rated voltage	U	V	323 ... 528			
Mains rated frequency	f	Hz	45 ... 69			
Input rated current	I	A	14.2	15.8	20.0	26.0
Fuses 3ph/PE	I	A	25	25	35	35
DC-bus rated voltage	$U_{DC}$	V	U x 1.41			
Overvoltage category	-	-	DIN EN 50178 III			
<b>General</b>						
Short circuit / earth protection	-	-	Yes, unlimited			
Mounting position	-	-	Vertical			
Degree of protection	-	-	IP 20 (EN 60529)			
Dimensions	HxWxD	mm	200 x 125 x 205			
Fan cooling	-	-	Yes			
<b>Environment</b>						
Coolant temperature	$T_n$	°C	From 0 to 40 (40 ... 55 with derating)			
Humidity	-	%	5 ... 85, no condensing			
Power dissipation	-	W	235	321	393	470
<b>Options &amp; accessories</b>						
Brake-chopper	-	-	Integrated			
Line choke	-	-	Option			
EMI filter	-	-	class A (EN 61800-3) integrated / class B (external) option			
Braking resistor	-	-	Option			
Operator panel	-	-	Integrated			
Communication interfaces	-	-	RS485 Modbus integrated / Systembus integrated / CANopen integrated RS232 option / Profibus DP option			

# Dimensions

	Size 1	Size 2	Size 3
<b>[mm]</b>			
A	170	196	205
B	60	80	125
C	200	200	200

## Size 1

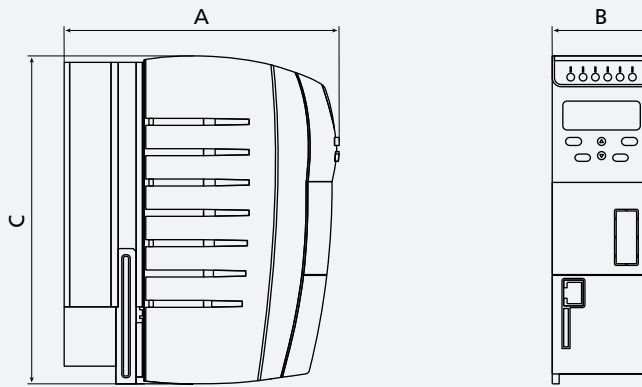

## Size 2

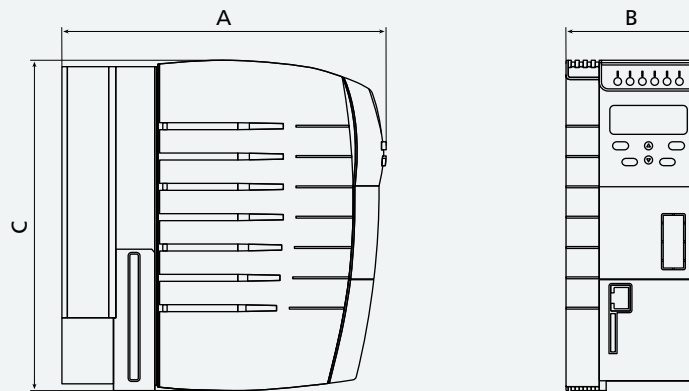

## Size 3

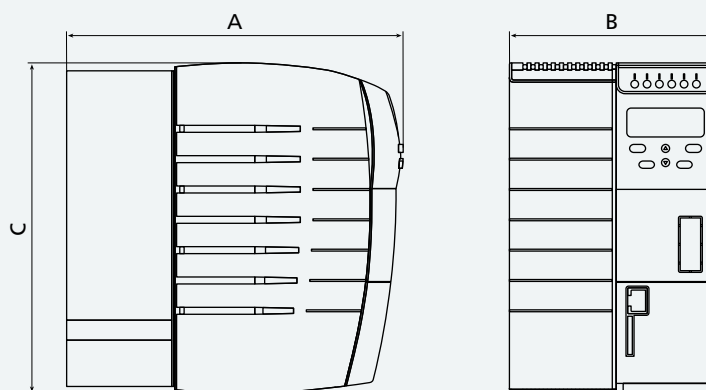

## Standards and Regulations

### Obligatory compliance:

<b>DIN EN 61800-1</b> 1999-08	Adjustable Speed Electrical Power Drive System - part 1: - General requirements - Rating specifications for Low Voltage Adjustable Speed d.c. Power Drive Systems (IEC 61800-1:1997) - German version EN 61800-1:1998
<b>DIN EN 61800-2</b> 1999-08	Adjustable Speed Electrical Power Drive System - part 2: - General requirements - Rating specifications for Low Voltage Adjustable Frequency a.c. Power Drive Systems (IEC 61800-2:1998) German version EN 61800-2:1998
<b>DIN EN 61800-3</b> 2005-07	Adjustable Speed Electrical Power Drive System - part 3: - EMC requirements and specific test methods (IEC 61800-3:2004) - German version EN 61800-3:2004
<b>DIN EN 61800-5-1 Amend. 2</b> 2006-01	Adjustable Speed Electrical Power Drive System - part 5-1: - Safety requirements - Electrical thermal and energy (IEC 61800-5-1:2003) German version EN 61800-5-1:2003 Amend. to DIN EN 618000-5-1
<b>DIN EN 61000-2-2</b>	Harmonic current limits
<b>DIN EN 61000-2-12</b>	Harmonic current limits
<b>DIN EN 50178</b> 1998-04	Electronic equipment for use in power installations German version EN 50178:1997
<b>2006/95/EC</b>	Low Voltage Directive
<b>89/336/EEC</b>	EMC Directive

### Possible certifications:

<b>UL (508c)</b>	UL Standard for Safety for Power conversion equipment
<b>cUL (CSA C22.2 No. 14)</b>	
<b>CE</b>	
<b>C-Tick</b>	
<b>CCC</b>	
<b>GOST</b>	

## Optional modules

Even in their basic configuration, Agile drives are equipped with an on-board RJ45 connector for use with communications ports.

Nevertheless, if you wish to extend the opportunities for field network integration you can install an optional module with an additional network interface.

Agile drives can therefore be integrated in existing field buses simply by adapting drive communications to the hardware and software of the existing communications standard.

Agile drives use exactly the same communication modules as Bonfiglioli's Active Series. They also enjoy the same plug & play functionality, so that the drive recognises and enables the new module automatically as soon as it is powered on.



Agile drives support various communication standards. Some of these do not require any optional equipment while others require the corresponding module to be installed. See the table alongside.

All optional modules are identical in shape and size, but differ in electronic functioning according to the standards of the type of field bus they communicate with.

Communication modules are installed in slots in the front of the drive. Simply remove the protective cover to access the slots. A secure push-fit ensures an efficient electrical connection.

With the front panel removed, the DB9 connector for the mains connection module is also accessible.

Field bus	Optional module
Profibus DP V1	CM-PDP
CANopen	CM-CAN
RS-485 Modbus	CM-485
RS-232	CM-232

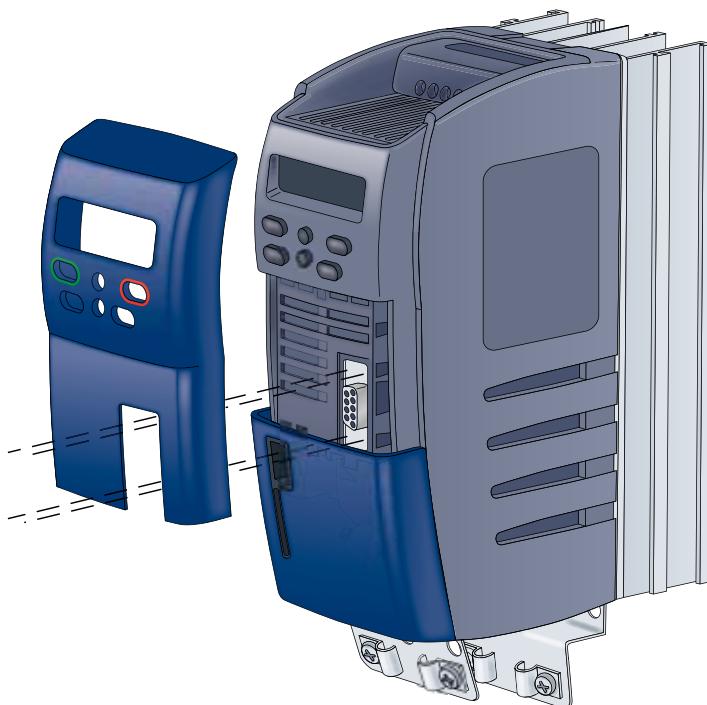

# Mounting

## Installation equipment

There are a number of different ways to install Agile inverter drives inside control panels. Drives can be installed using the metal brackets supplied or using one of the various optional kits.

The following table summarises what installation equipment is available for what inverter sizes.

Inverter		Standard mounting (supplied)	Feed-through mounting (optional)	DIN rail mounting (optional)	Anti-vibration mounting (optional)
Size	Type	MSTD kit	MPSV kit	MDIN kit	MNVIB kit
1	AGL402-02 1 F A	MSTD12-AGL	MPSV1-AGL	MDIN1-AGL	MNVIB1-AGL
	AGL402-03 1F A				
	AGL402-05 1 F A				
	AGL402-07 1 F A				
	AGL402-09 1 F A				
	AGL402-11 1 F A				
	AGL402-13 1 F A				
2	AGL402-15 2 F A		MPSV2-AGL		MNVIB2-AGL
	AGL402-18 2 F A				
3	AGL402-19 3 F A	MSTD3-AGL	MPSV3-AGL	-	MNVIB3-AGL
	AGL402-21 3 F A				
	AGL402-22 3 F A				
	AGL402-23 3 F A				

# Mounting

## MSTD kit (standard mounting)

This kit comprises two brackets that engage with slots in the drive's heat sink fins. The brackets are

fixed to the inside wall of the control panel with two screws.

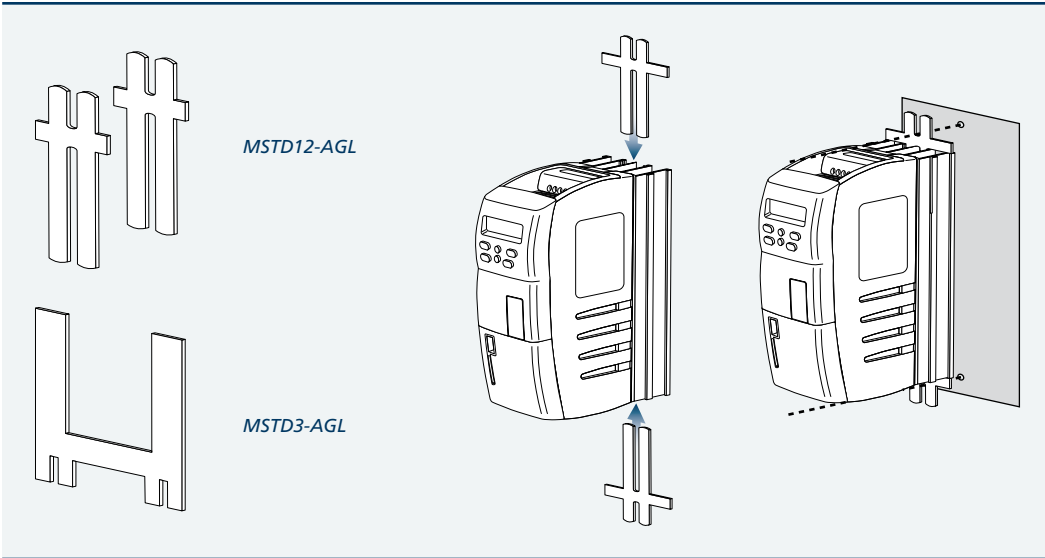

## MPSV kit (feed-through mounting)

When heat has to be dissipated outside the control panel, or component depth minimised, the feed-through mounting kit lets you install the drive

with the heat sink outside and the rest of the drive inside the control panel.

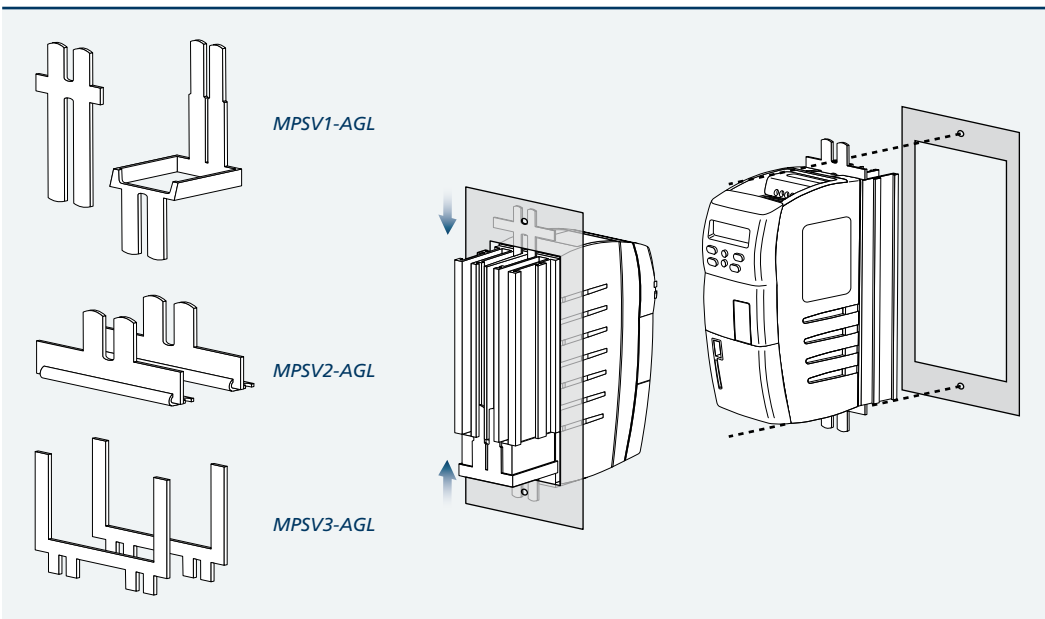

# Mounting

## MDIN kit (DIN mounting)

Only available for Agile size 1 drives, the MDIN kit comprises a metal plate that engages with slots in

the drive's heat sink fins and allows the drive to be installed on a DIN rail inside the control panel.

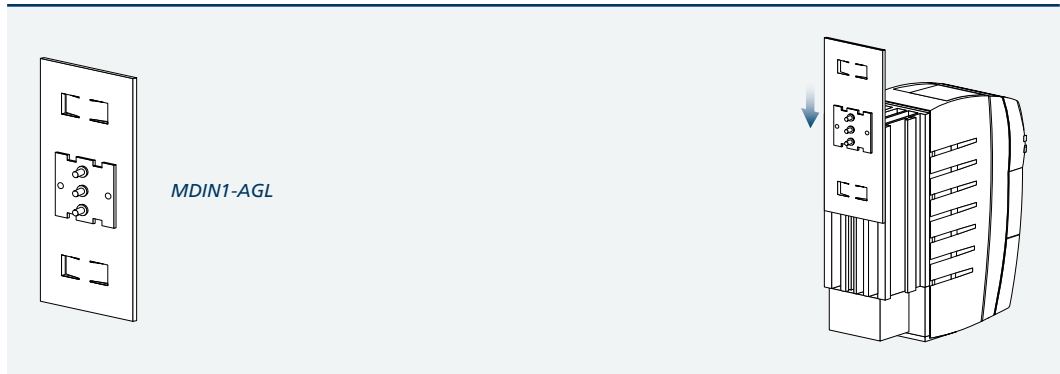

## MNVIB kit (vibration proof mounting)

Designed for installation in high vibrations environment, the MNVIB kit consists of two inserts

to introduce between the heat sink fins to assure greater strength of attachment.

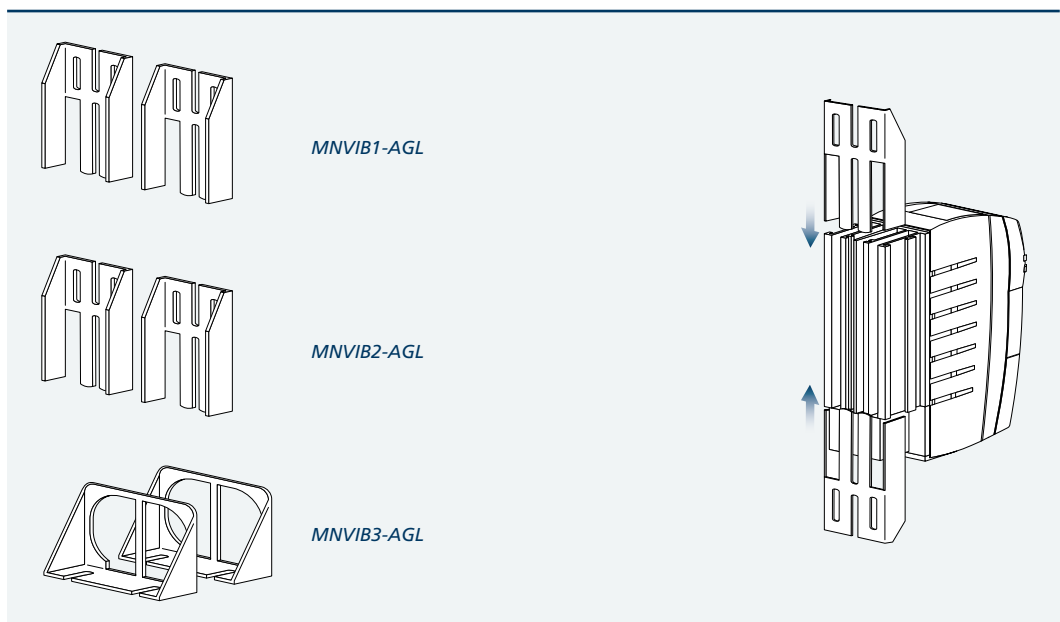

# Mounting

## Cold Plate design form

The Agile' s standard version is executed with integrated heat-sink which contributes to define the inverter overall dimensions allowing optimal performances by means of suitable heat disposal.

For special applications requiring space saving or compliance with heavy environmental regimes, Agile offers an alternative design form, cold plate version, on demand during purchase order emission.

The cold plate version is realized without built-in cooling ribs which instead must be prepared by the user according to parameters reported on the relevant technical manual.

In that configuration the drive backside ends with smooth metal plate able to be fixed to an auxiliary heat-sink by means of specific mounting kit.

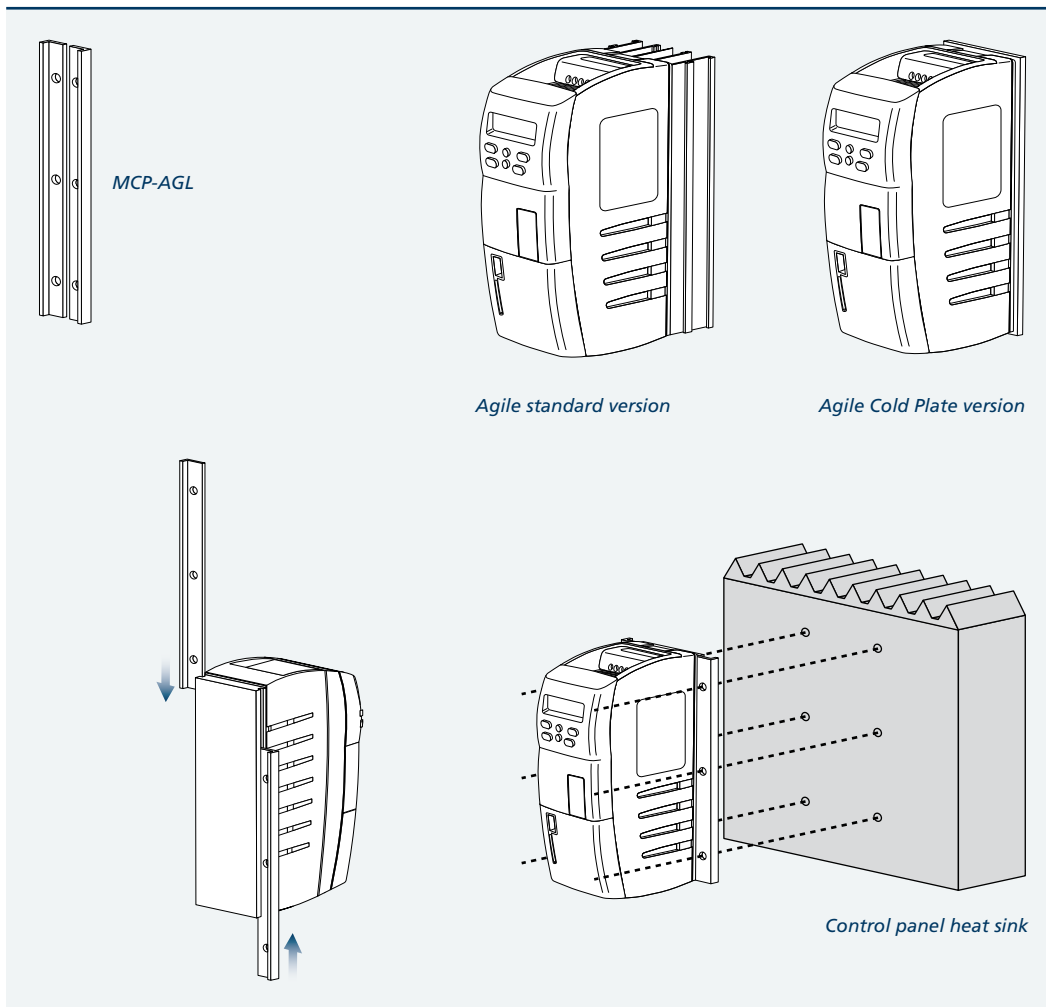



## ASK-USB serial connection kit

Agile inverter drives are equipped with a number of different communication interfaces. Some of these (RS485, CAN-Systembus) are integrated in the basic product, while others (RS232, CAN, Profibus) are only available if the corresponding CM optional module is installed in the drive.

The RS485 port is integrated and accessible via the RJ45 connector on the front panel. This port is able

to communicate using Modbus RTU protocol and Bonfiglioli Vectron's own proprietary protocol.

The ASK-USB connection kit allows you to connect your Agile drive to your computer's USB port. The kit comprises three components:

- an RS485 / USB converter
- a connection cable to the drive
- a connection cable to the computer

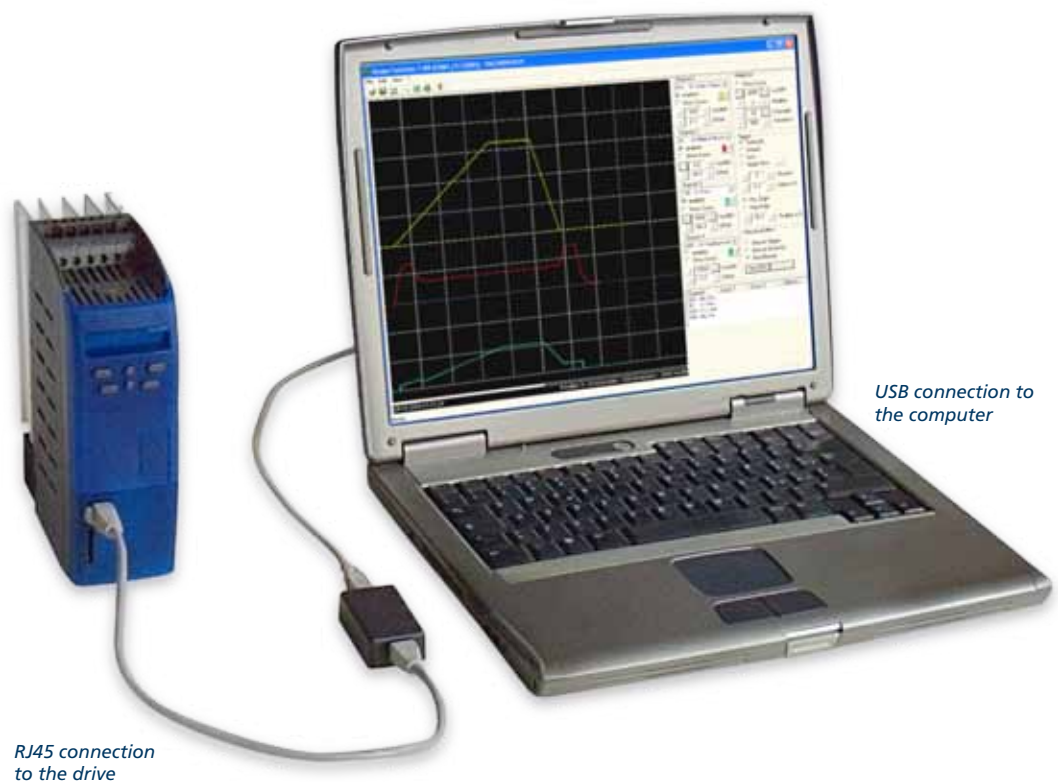
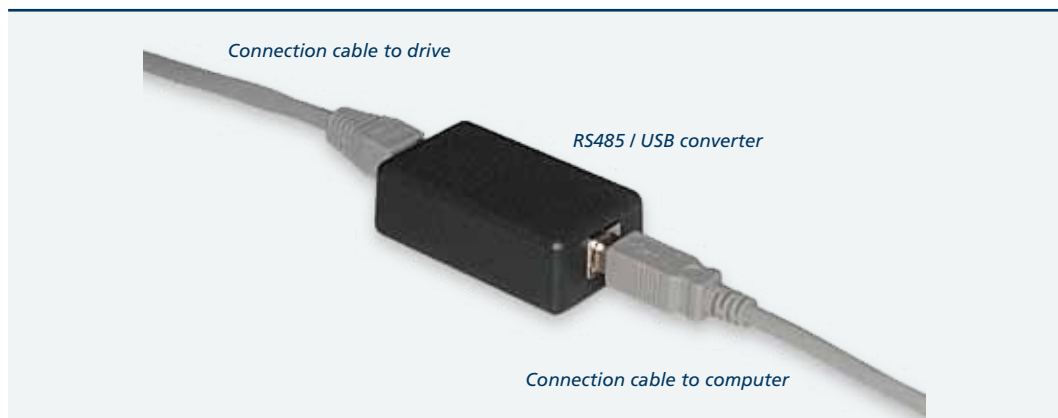

# Braking resistors



## Regenerative mode

When an inverter-controlled electric motor is braking, it becomes regenerative and returns electrical energy to the drive.

This causes voltage in the drive's intermediate circuit to rise to a value at which it becomes necessary to dispose of excess energy through a recovery system or through external dissipative components.

Agile drives support both methods of regeneration energy management and provide a DC-bus power connection to other drives capable of using the excess energy, and a connection to a braking resistor for the thermal dissipation of energy.

## Braking Resistor

All Agile drives have a built-in braking chopper for use with a range of Bonfiglioli braking resistors,

selected to suit the duty cycle of the application.

BR Series braking resistors are safe and compact, offer an index of protection of IP20 and above, are suitable for panel mounting and feature integrated thermal protection.

BR resistors can be used with all Bonfiglioli drives, from the AGL Series to the ACT, ACU and VCB Series. Each resistor is identified by a power rating and a resistance value, which form the criteria for combination with different drive ratings.

To help identify the most suitable braking resistors for different drives and applications, the following table suggests pairings that allow drives to dissipate their full rated power to the resistor for a limited by cyclically repeatable time.

Type	Inverter	Recommended Bonfiglioli resistor			Reference cycle*	
	Rated power	Type	Continuous power	Resistance**	Dissipated power	Duty cycle
	$P_n$ [kW]		[W]	[ $\Omega$ ]	$P_R$ [kW]	$\delta P$ [%]
AGL 402-02	0.25	BR 213/300	213	300	0.25	84
AGL 402-03	0.37	BR 213/300	213	300	0.37	56
AGL 402-05	0.55	BR 213/300	213	300	0.55	38
AGL 402-07	0.75	BR 213/300	213	300	0.75	28
AGL 402-09	1.1	BR 213/300	213	300	1.1	19
AGL 402-11	1.5	BR 213/300	213	300	1.5	14
AGL 402-13	2.2	BR 471/136	471	136	2.2	21
AGL 402-15	3.0	BR 471/136	471	136	3.0	16
AGL 402-18	4.0	BR 696/92	696	92	4.0	17
AGL 402-19	5.5	BR 1330/48	1330	48	5.5	24
AGL 402-21	7.5	BR 1330/48	1330	48	7.5	18
AGL 402-22	9.2	BR 1330/48	1330	48	9.2	14
AGL 402-23	11	BR 2000/32	2000	32	11	18

\* referred to a period of 120 seconds

\*\* Don't apply resistance values lower than displayed

Since each resistor has a lower continuous rated power value than the corresponding drive, it is important to respect the specified dissipation cycle. Though the component will heat up, this cycle permits adequate cooling.

The purpose of the reference cycle is to inform users that over a period of 120 seconds, braking time must not exceed  $1.2 \delta_R$  seconds, or the resistor will overheat.

The reference cycle is therefore a limit cycle and must not be exceeded.

Given an application with a user-defined period  $T$ , during which the drive's full rated power is deviated to the resistor, braking time must not exceed the value of  $T_{Fmax}$  calculated on the basis of the reference cycle.

## Braking cycle

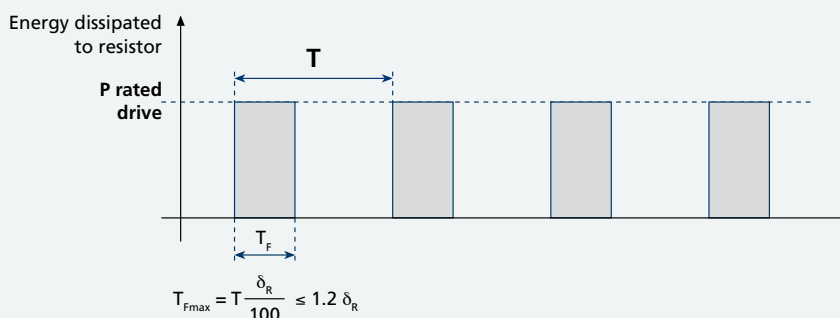

## Line choke

### Harmonic handling

Current harmonics at the drive's power inputs can attenuate a system's active power. The best solution for dealing with harmonics is to install line chokes in series with each phase.

The mains power supply has its own intrinsic inductance. The addition of line chokes boosts this to offer ever greater impedance to higher harmonic components and act effectively as a low-pass filter.

Line chokes should have a short circuit rating some 20 to 40 times greater than the rated power of the drive and should produce voltage drops no greater than 4%.

Bonfiglioli can provide a range of line chokes satisfying these criteria for use with different drive sizes according to the table below.

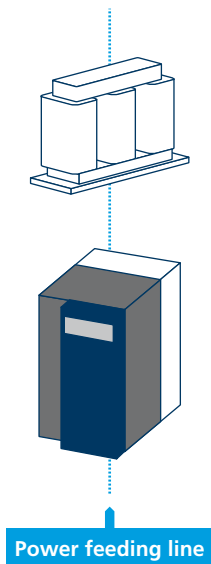

Inverter	Recommended Bonfiglioli line choke
AGL402-02	LCVT004
AGL402-03	LCVT004
AGL402-05	LCVT004
AGL402-07	LCVT004
AGL402-09	LCVT004
AGL402-11	LCVT004
AGL402-13	LCVT006
AGL402-15	LCVT008
AGL402-18	LCVT010
AGL402-19	LCVT015
AGL402-21	LCVT018
AGL402-22	LCVT025
AGL402-23	LCVT034

**Added value**



## Sharing the value of our work with you.



The development of effective, tailored solutions for a wide range of applications is a fundamental aspect of our work.

We succeed in this because we co-operate closely with our customers, listen to their requests and work with them to improve our own performance.



Bonfiglioli is determined to deliver the best service possible – before, during and after the sale of any of our products – by applying all our know-how, experience, technology, and advanced communication tools. Bonfiglioli works to the strictest standards of quality and safety, as certified by seven different internationally recognised institutes.



We believe in innovation, and back up this belief by dedicating 100 of our people and 5 activity centres to research and development, and by working hand in hand with some of the world's most prestigious universities.

Our work increasingly brings us into contact with other nations and cultures, for which we have the greatest respect and with whom we share a vision of sustainable development based on renewable energy.

This bond of commitment allows us to be an authoritative and reliable global partner for the present and the future.



# Branches and facilities

## Our branches

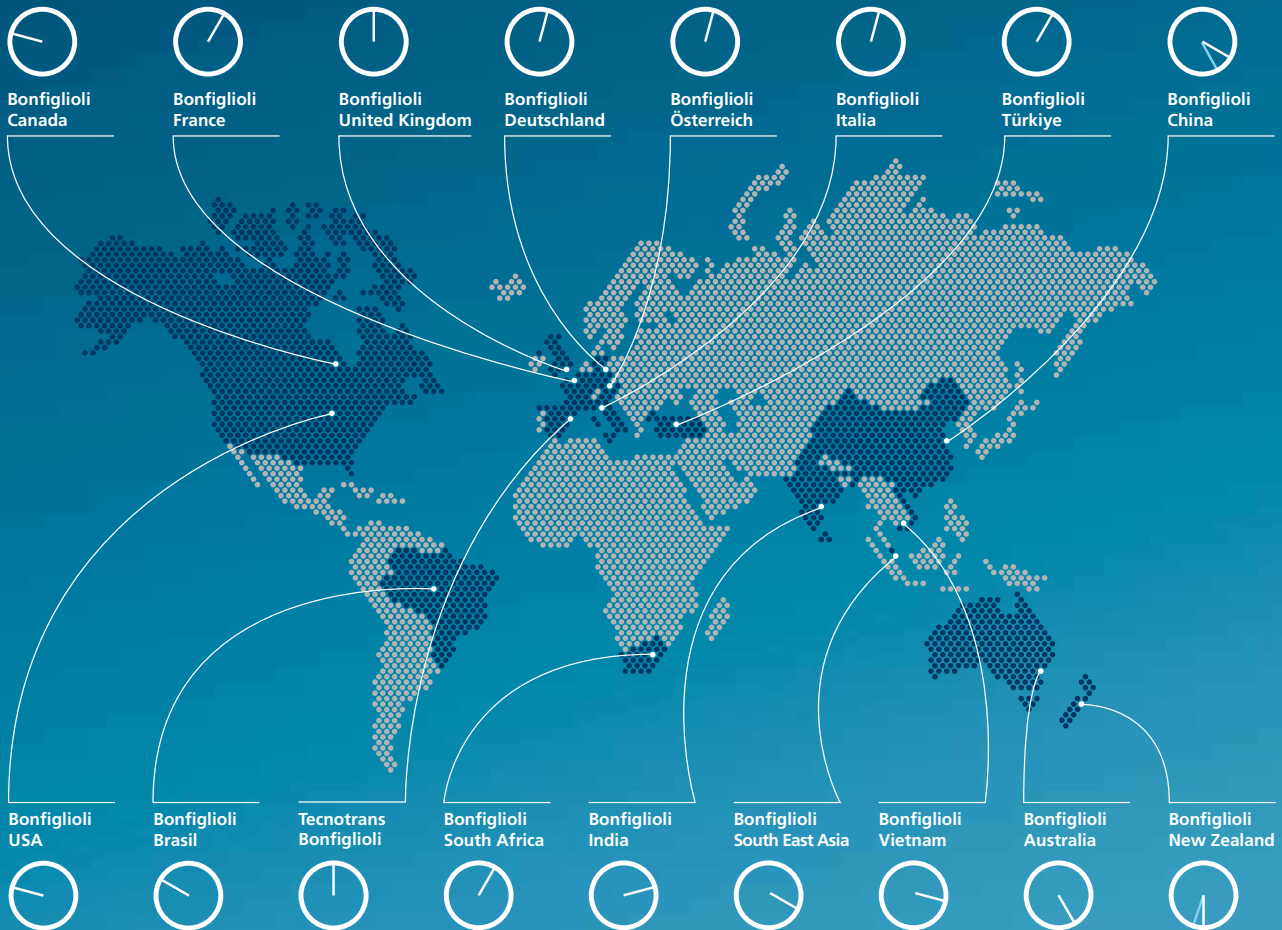

## Our production facilities



## Bonfiglioli is your partner worldwide for power transmission and motion control.

Customer satisfaction has always been one of Bonfiglioli's key values. It is pursued around the world, and in a wide range of contexts, by a network of subsidiaries located in 17 countries and on 5 continents.

Each subsidiary provides rapid and efficient pre-sales and after-sales service, and can guarantee prompt deliveries from local assembly plant and warehouses.

In addition to our directly controlled subsidiaries, Bonfiglioli can also rely on an extensive network of authorised dealers, selected for their ability to guarantee excellent pre-sales and after-sales assistance.

To give everybody the chance to purchase a Bonfiglioli product - anywhere.

This is the ambitious objective that drives the development of our added value sales networks, off and on-line.

BEST (Bonfiglioli Excellence Service Team) is one of the most modern sales organisations in the field of power transmission.

Our BEST partners can benefit from our local assembly plant and warehouses, our training courses and tools, and our promotional activities.

For the first time ever, manufacturer and distributors are working together from the product assembly stage and in the design of new applications, in a sharing process that sees one party transferring know-how and technology and the other partly providing a thorough knowledge of the local market.



## Bonfiglioli worldwide network.

### Bonfiglioli Australia

2, Cox Place Glendenning NSW 2761  
Locked Bag 1000 Plumpton NSW 2761  
Tel. (+ 61) 2 8811 8000 - Fax (+ 61) 2 9675 6605  
www.bonfiglioli.com.au - sales@bonfiglioli.com.au

### Bonfiglioli Brazil

Travessa Cláudio Armando 171 - Bloco 3  
CEP 09861-730 - Bairro Assunção  
São Bernardo do Campo - São Paulo  
Tel. (+55) 11 4344 1900 - Fax (+55) 11 4344 1906  
www.bonfigliolidobrasil.com.br  
bonfiglioli@bonfigliolidobrasil.com.br

### Bonfiglioli Canada

2-7941 Jane Street - Concord, Ontario L4K 4L6  
Tel. (+1) 905 7384466 - Fax (+1) 905 7389833  
www.bonfigliolicanada.com  
sales@bonfigliolicanada.com

### Bonfiglioli China

19D, No. 360 Pu Dong Nan Road  
New Shanghai International Tower  
200120 Shanghai  
Tel. (+86) 21 5054 3357 - Fax (+86) 21 5970 2957  
www.bonfiglioli.cn - bdssales@bonfiglioli.com.cn

### Bonfiglioli Deutschland

Sperberweg 12 - 41468 Neuss  
Tel. (+49) 02131 2988-0  
Fax (+49) 02131 2988-100  
www.bonfiglioli.de - info@bonfiglioli.de

### Bonfiglioli España

TECNOTRANS BONFIGLIOLI S.A.  
Pol. Ind. Zona Franca sector C, calle F, nº6  
08040 Barcelona  
Tel. (+34) 93 4478400 - Fax (+34) 93 3360402  
www.tecnotrans.com - tecnotrans@tecnotrans.com

### Bonfiglioli France

14 Rue Eugène Pottier BP 19  
Zone Industrielle de Moimont II  
95670 Marly la Ville  
Tel. (+33) 1 34474510 - Fax (+33) 1 34688800  
www.bonfiglioli.fr - btf@bonfiglioli.fr

### Bonfiglioli India

PLOT AC7-AC11 Sidco Industrial Estate  
Thirumudivakkam - Chennai 600 044  
Tel. +91(0) 44 24781035 - 24781036 - 24781037  
Fax +91(0) 44 24780091 - 24781904  
www.bonfiglioliindia.com - bonfig@vsnl.com

### Bonfiglioli Italia

Via Sandro Pertini lotto 7b  
20080 Carpiano (Milano)  
Tel. (+39) 02 985081 - Fax (+39) 02 985085817  
www.bonfiglioli.it  
customerservice.italia@bonfiglioli.it

### Bonfiglioli New Zealand

88 Hastie Avenue, Mangere Bridge, Auckland  
2022, New Zealand - PO Box 11795, Ellerslie  
Tel. (+64) 09 634 6441 - Fax (+64) 09 634 6445  
npollington@bonfiglioli.com.au

### Bonfiglioli Österreich

Molkereistr 4 - A-2700 Wiener Neustadt  
Tel. (+43) 02622 22400 - Fax (+43) 02622 22386  
www.bonfiglioli.at - info@bonfiglioli.at

### Bonfiglioli South East Asia

No 21 Woodlands industrial park E1  
#02-03 Singapore 757720  
Tel. (+65) 6893 6346/7 - Fax (+65) 6893 6342  
www.bonfiglioli.com.au  
sales@bonfiglioli.com.sg

### Bonfiglioli South Africa

55 Galaxy Avenue,  
Linbro Business Park - Sandton  
Tel. (+27) 11 608 2030 OR - Fax (+27) 11 608 2631  
www.bonfiglioli.co.za  
bonfigsales@bonfiglioli.co.za

### Bonfiglioli Türkiye

Atatürk Organize Sanayi Bölgesi,  
10015 Sk. No: 17, Çigli - Izmir  
Tel. +90 (0) 232 328 22 77 (pbx)  
Fax +90 (0) 232 328 04 14  
www.bonfiglioli.com.tr  
info@bonfiglioli.com.tr

### Bonfiglioli United Kingdom

**Industrial Solutions**  
Unit 7, Colemeadow Road  
North Moons Moat - Redditch,  
Worcestershire B98 9PB  
Tel. (+44) 1527 65022 - Fax (+44) 1527 61995  
www.bonfiglioli.com  
uksales@bonfiglioli.com

**Mobile Solutions**  
3 - 7 Grosvenor Grange, Woolston  
Warrington - Cheshire WA1 4SF  
Tel. (+44) 1925 852667 - Fax (+44) 1925 852668  
www.bonfiglioli.co.uk  
mobilesales@bonfiglioli.co.uk

### Bonfiglioli USA

3541 Hargrave Drive Hebron, Kentucky 41048  
Tel. (+1) 859 334 3333 - Fax (+1) 859 334 8888  
www.bonfiglioliusa.com  
industrialsales@bonfiglioliusa.com  
mobilesales@bonfiglioliusa.com

### Bonfiglioli Vietnam

Lot C-9D-CN My Phuoc Industrial Park 3  
Ben Cat - Binh Duong Province  
Tel. (+84) 650 3577411 - Fax (+84) 650 3577422  
www.bonfiglioli.vn - salesvn@bonfiglioli.com







Bonfiglioli has been designing and developing innovative and reliable power transmission and control solutions for industry, mobile machinery and renewable energy applications since 1956.