



WESTCAR s.r.l.

BRAKES

Code 17491

BD Drum Brakes **CD Disc Brakes**

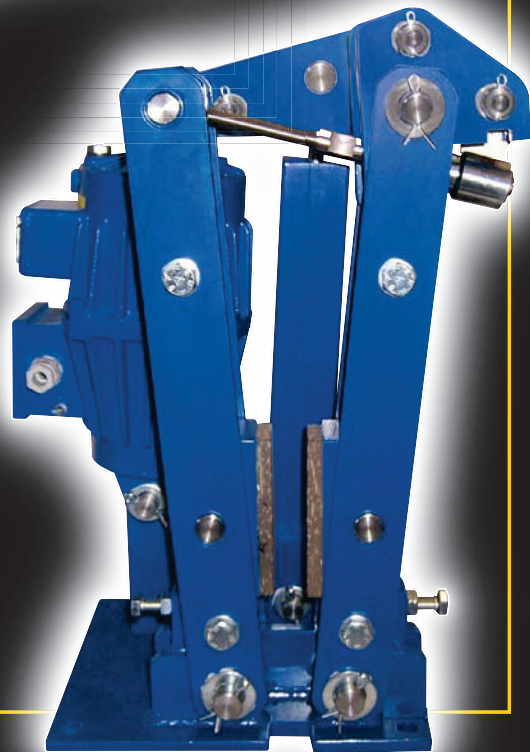

APPLICATIONS

- Brake for lifting service
- Brake for translater service
- Safety brake
- Emergency brake

TECHNICAL FEATURES

- Welded steel frame in according to DIN 15435 (drum brakes) zinc coated steel frame (disc brake)
- Epoxy resin painting (2 coatings) with RAL 5010 final color
- Manganese phosphated pins (drum brakes), stainless steel pins (disc brakes)
- Light alloy drums with asbestos free glued braking pads (drum brakes)
- Friction coefficient $\mu=0,42$
- Asbestos free lining pads, glued to easy-to-replace plates (disc brakes).
- Braking torque scale indicator
- Protection grade IP 56

OPERATION

- WC Drum and disc brake are negative
- The braking force is obtained by means of a spring that, through a suitable system of levers, transmits its amplified action to the braking pads.
- An electrohydraulic or pneumatic thruster makes an opposite force to the spring, causing the pads open, therefore the brake to release.
- The braking force of the linings against the drum can be modulated by adjusting the spring.
- Braking torque changes depending on braking force modulation.

THRUSTOR TYPES

- **WC** Electrohydraulic WESTCAR (standard)
- **ET** Electrohydraulic ELTMA
- **ED** Electrohydraulic ELDRO
- Pneumatic

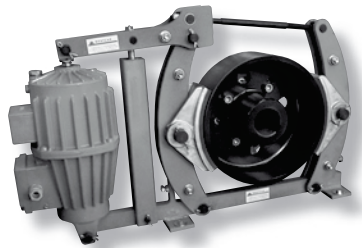

Tab. A

Brake Series BD	THRUSTOR MAXIMUM BRAKE TORQUE Nm						
	WC 22/50	WC 30/50	WC 60/50	WC 75/50	WC 80/60	WC 200/60	WC 300/60
160	120						
200	160	240	-	-	-		
250	210	320	500			-	
315	250	350	700	1.000	1.120		-
400		500	870	1.250	2.100		
500	-	-	1.100	1.600	2.700	4.400	
630			-	-	3.270	5.400	7.800

ABBREVIATION OF DRUM AND DISC BRAKES

- **RG** Automatic wear compensation device
- **FCU** Maximum wear indicator
- **FCA** Open brake indicator
- **LSM** Manual disengagement lever.
- **SV** Adjustable delay valve
- Protection grade IP 65
- Stainless steel pins instead of phosphated pins (drum brakes)
- Braking drums 50% wider (drum brakes)

BRAKE SELECTION DATA

- Type of application.
- Stop for hour
- Required voltage (standard 220/440V-50Hz)
- Accessori richiesti
- Diametro e larghezza fascia freno
- Diametro disco. Spessore standard 30mm.
- Air pressure supply (In case of pneumatic actuator)

Drum brakes only

- L special large drums
- INOX stainless steel pins

Disc brakes only

- DX rasecuzione destra
- DS left hand execution

QUICK SELECTION TABLES

- **TAB A** Drum Brake
- **TAB B** Disc Brake



Tab. B

Brake Series CD	Disc Dia. mm	THRUSTOR MAXIMUM BRAKE TORQUE Nm					
		WC 22/50	WC 30/50	WC 60/50	WC 80/60	WC 200/60	WC 300/60
DS 0	250	195	265				
	315	250	340				
	400	330	450				
	450	380	520				
	500	430	530				
DS 1	355	290	435	870			
	400	340	490	980			
	450	390	530	1060			
	500	440	575	1150			
DS 2	450			1350	2700	4500	
	500			1500	3000	5000	
	560			1700	3400	5700	
	630			1850	3700	6200	
	710			2100	4200	7000	
DS 3	630	-	-		3900	6500	9750
	710				4410	7350	11000
	800			-	5050	8500	12750
	1000				6300	10500	15750
	1250				7700	12800	19000

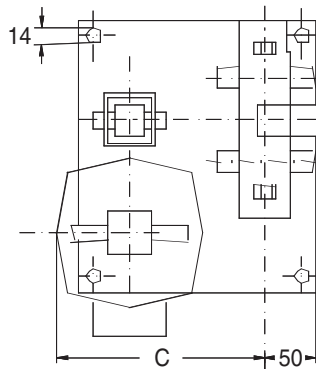
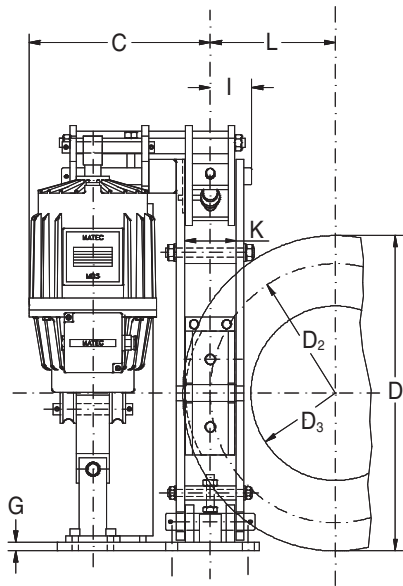
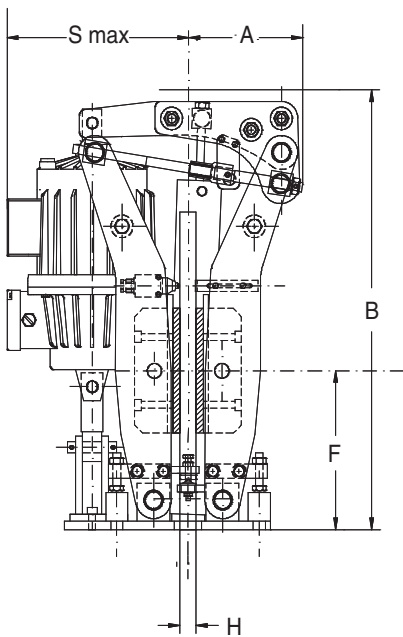

For CD0 model

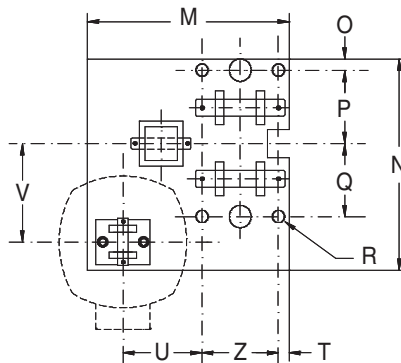

Series CD	DISC			
	D ₁	D ₂	D ₃	L
0	250	200	110	98
	315	260	170	130
	400	345	255	173
	450	395	305	197
	500	445	355	222
1	355	275	160	138
	400	320	205	160
	450	370	255	185
	500	420	305	210
2	450	350	200	175
	500	400	250	200
	560	460	310	230
	630	530	380	265
	710	610	460	305
3	630	500	310	250
	710	580	390	290
	800	670	480	335
	1000	870	680	435
	1250	1120	930	560

Right-hand brake with option
RG-FCU-LSM as drawn.
Left handling on request.
All data subject to change without
notices.

Series CD	Thrustor WC series	Dimensions mm																			
		A	B max	C	F	G	H	I	K	M	N	O	P	Q	R		S max	T	U	V	Z
															Nr	Ø					
0	22/50	123	487	201	160			50	-	230	260	15	-	-	4	14	216	-	-	-	-
	30/50			214													241				
1	22/50	190	650	221	230	15	30	62	70	300	300	20	80	180	18	20	246	90	140	120	
	30/50			234													268				
	60/50			246													276				
2	60/50	210	800	316	280			75	90	370	375	20	130	130	22		311	145	175	140	
	80/60			332													330				
	200/60			352													341				
3	80/60	235	1050	352	370	20		95	120	410	460	20	180	180	27		350	30	155	187	160
	200/60			372													361				
	300/60																				

Dimensions are subject to alteration without notice